

EVE-TR-X-25-AC3

J. Schmalz GmbH
 Johannes-Schmalz-Straße 1
 D - 72293 Glatten
 Tel +49 +7443 / 2403 - 0
 Fax +49 +7443 / 2403 - 259
 http://www.schmalz.com
 e-mail: schmalz@schmalz.de

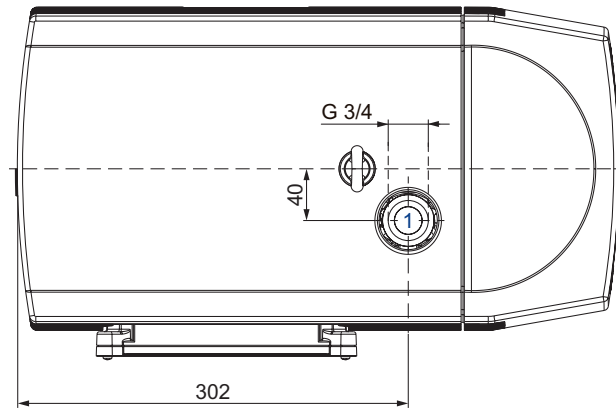

TDS 30.30.01.02975 Status 10.08.2021

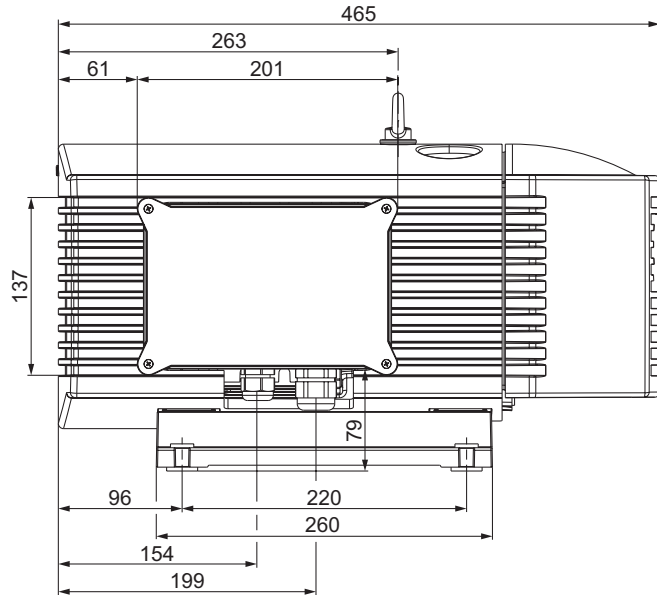
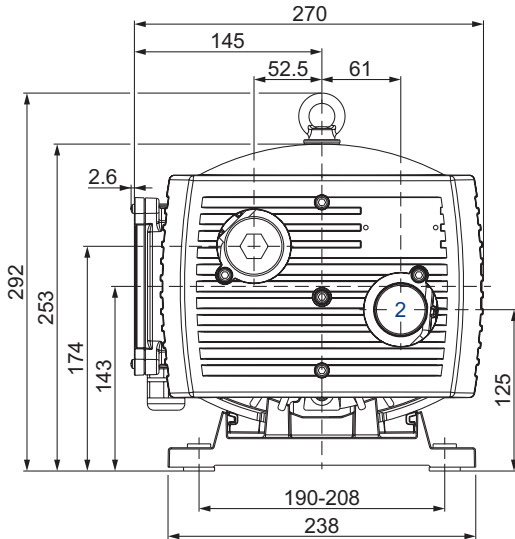

- 1 Sauganschluss
Vacuum connection
Raccord vide
- 2 Abblaseventil
Blow-off valve
Soupape d'échappement

m ³ /h		mbar abs.		kg	dB(A) ¹⁾	
50 Hz	60 Hz	50 Hz	60 Hz		50 Hz	60 Hz
25	30	100	100	≈ 28.5	62	67

M	50 Hz				60 Hz				complies with the following standards ²⁾	No		
	kW	V	min ⁻¹	A	kW	V	min ⁻¹	A				
3~	0.75	Y400	IE3	1450	1.9	0.9	YY230/Y460 YY208 Y400	IE3 IE3 -	1745 1730 1725	3.6/1.8 3.7 1.9	UL / CSA / CC IP55 / ISO F / PTO (bimetal) 150°C	10.03.01.00351

¹⁾ DIN EN ISO 3744 (KpA = 3 dB(A)) – Abstand von 1 m, bei mittlerer Belastung, beide Seiten abgeleitet

DIN EN ISO 3744 (KpA = 3 dB(A)) – interval of 1 m, at medium load, both connection sides piped

DIN EN ISO 3744 (KpA = 3 dB(A)) – intervalle de 1 m, à régime moyen, avec dérivation des deux côtés

²⁾ Entspricht den folgenden Standards → Details siehe Typenschild

Complies with the following standards → details see type plate

Conforme aux standards suivantes → voir la plaque signalétique

- Maßangaben in mm
- Änderungen vorbehalten

- Dimensions in mm
- Right of modification reserved

- Mesures en mm
- Sous réserve des modifications



Saugluftmenge • Suction air rate • Débit d'air aspiré

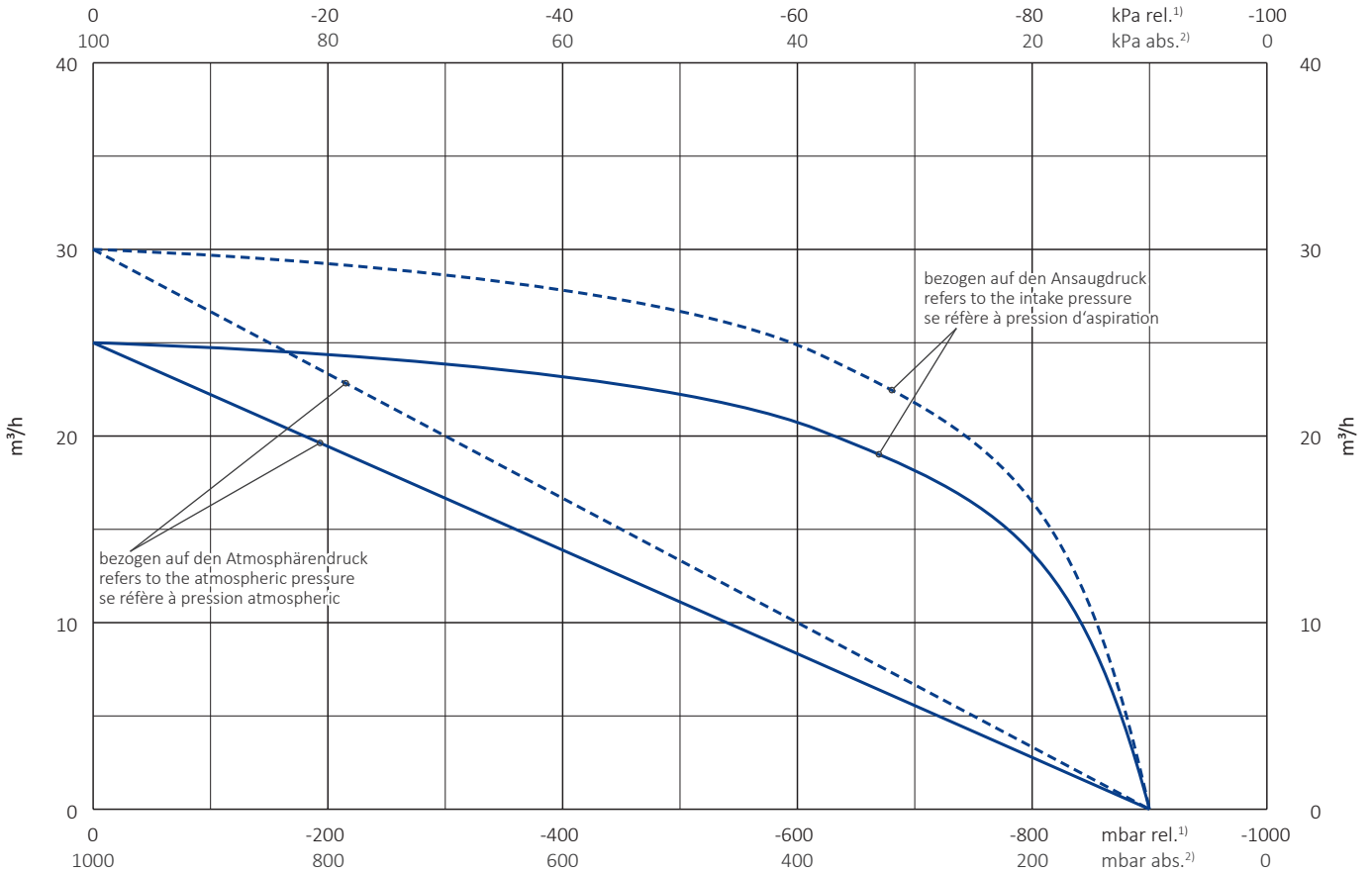

Ablufttemperatur • Exhaust air temperature • Temp. d'air à l'échappement

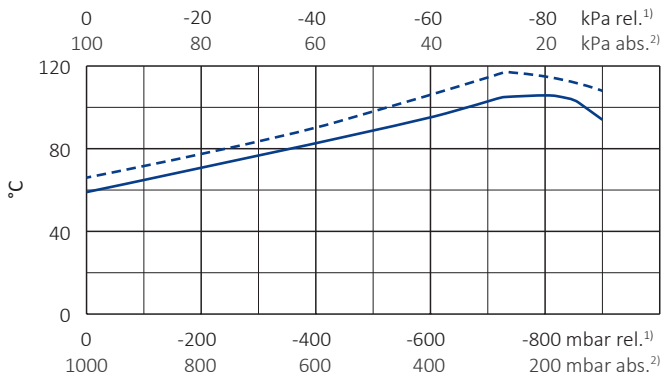

Wellenleistung • Motor shaft power • Puissance du moteur axe

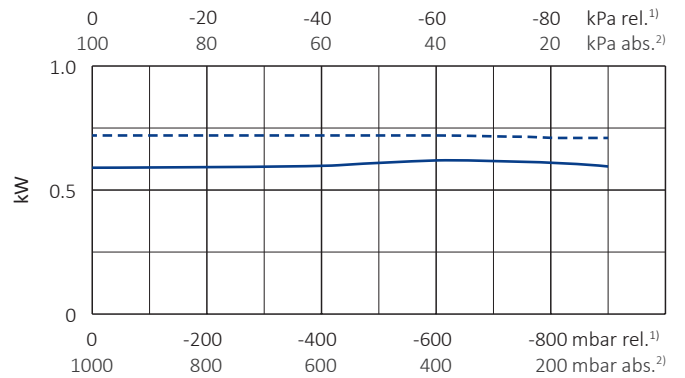

— 50 Hz
 - - - 60 Hz

1) relativ
 2) absolut

relative
 absolute

relatif
 absolu

• Bezugsdaten (Atmosphäre)
 • Toleranz
 • Änderungen vorbehalten

Reference data (atmosphere)
 Tolerance
 Right of modification reserved

Référence (atmosphère)
 Tolérance
 Sous réserve des modifications

1000 mbar, 20°C
 ±5 %