

EVE-TR-10-AC3
EVE-TR-10-AC

TDS 30.30.01.02796 Status 19.04.2023

J. Schmalz GmbH
Johannes-Schmalz-Straße 1
D - 72293 Glatten
Tel +49 +7443 / 2403 - 0
Fax +49 +7443 / 2403 - 259
http://www.schmalz.com
e-mail: schmalz@schmalz.de

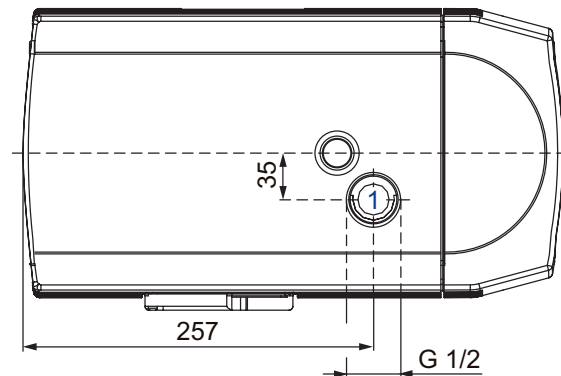
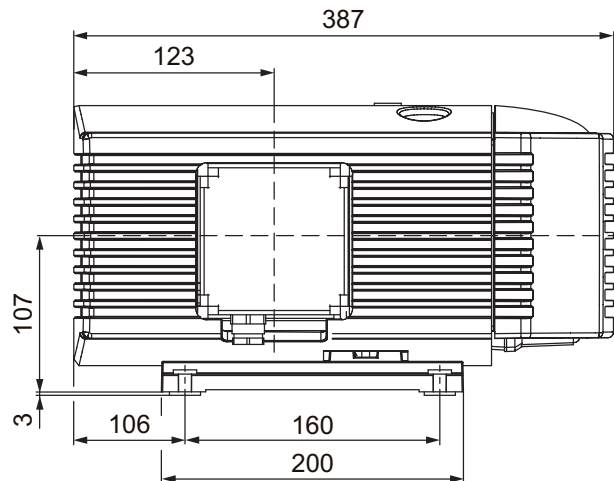
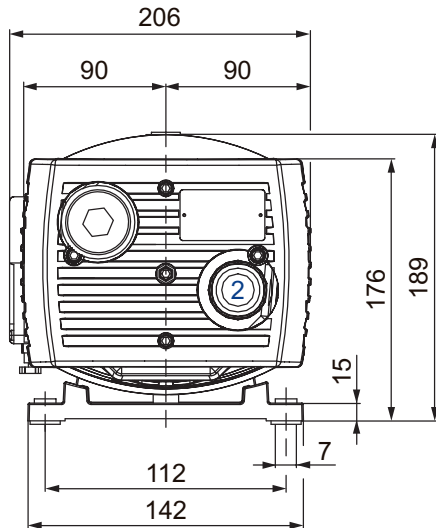

- 1 Sauganschluss
Vacuum connection
Raccord vide
- 2 Abblaseventil
Blow-off valve
Soupape d'échappement

m ³ /h		mbar abs.		kg	dB(A) ¹⁾	
50 Hz	60 Hz	50 Hz	60 Hz		50 Hz	60 Hz
10	12	150	150	≈ 16	60	62

Ⓜ	50 Hz				60 Hz				complies with the following standards ²⁾	No
	kW	V	min ⁻¹	A	kW	V	min ⁻¹	A		
3~	0.37	Δ175-260/Y300-450	1420	2.3/1.33	0.45	Δ202-300/Y350-520	1700	2.35/1.36	UL IP54 / ISO F	10.03.01.00137
1~	0.37	230 ±10%	1380	3.0	0.44	230 ±10%	1630	3.4	UL / CSA / bimetal IP54 / ISO F / 12 μF (400V)	10.03.01.00138

¹⁾ DIN EN ISO 3744 (KpA = 3 dB(A)) – Abstand von 1 m, bei mittlerer Belastung, beide Seiten abgeleitet

DIN EN ISO 3744 (KpA = 3 dB(A)) – interval of 1 m, at medium load, both connection sides piped

DIN EN ISO 3744 (KpA = 3 dB(A)) – intervalle de 1 m, à régime moyen, avec dérivation des deux côtés

²⁾ Entspricht den folgenden Standards → Details siehe Typenschild

Complies with the following standards → details see type plate

Conforme aux standards suivantes → voir la plaque signalétique

- Maßangaben in mm
- Änderungen vorbehalten

Dimensions in mm
Right of modification reserved

Mesures en mm
Sous réserve des modifications

EVE-TR-10-AC3
EVE-TR-10-AC

TDS 30.30.01.02796 Status 19.04.2023

J. Schmalz GmbH
Johannes-Schmalz-Straße 1
D - 72293 Glatten
Tel +49 +7443 / 2403 - 0
Fax +49 +7443 / 2403 - 259
http://www.schmalz.com
e-mail: schmalz@schmalz.de



Saugluftmenge • Suction air rate • Débit d'air aspiré

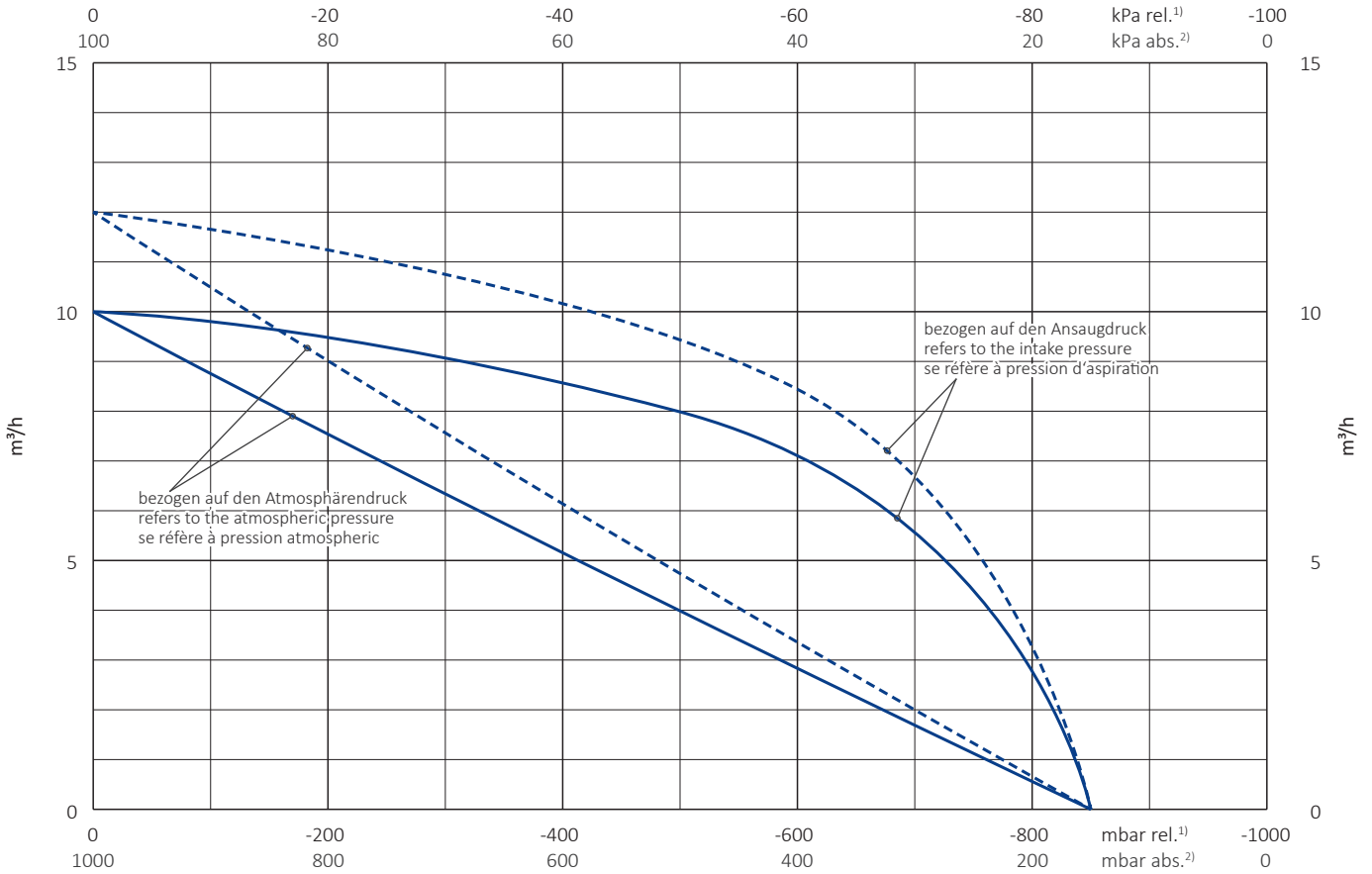

Ablufttemperatur • Exhaust air temperature • Temp. d'air à l'échappement

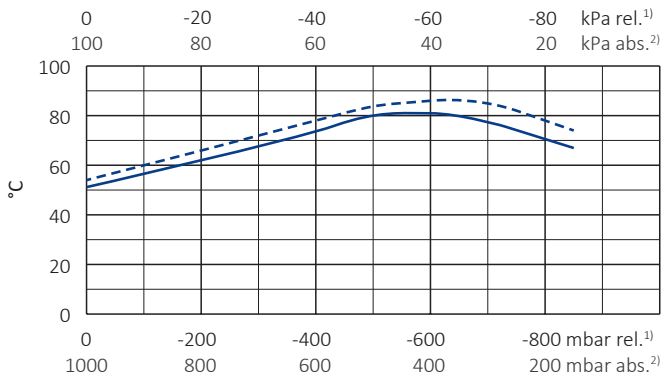

Wellenleistung • Motor shaft power • Puissance du moteur axe

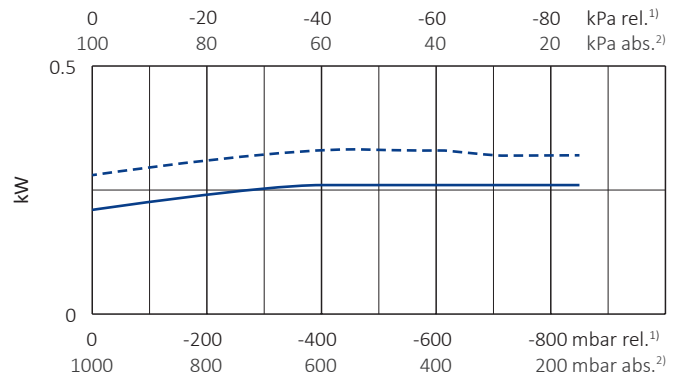

— 50 Hz
- - - 60 Hz

1) relativ
2) absolut

relative
absolute

relatif
absolu

• Bezugsdaten (Atmosphäre)
• Toleranz
• Änderungen vorbehalten

Reference data (atmosphere)
Tolerance
Right of modification reserved

Référence (atmosphère)
Tolérance
Sous réserve des modifications

1000 mbar, 20°C
±5 %