

## Bellows Suction Cups SAB HT1 (1.5 Folds)

Suction area (Ø) from 22 mm to 125 mm

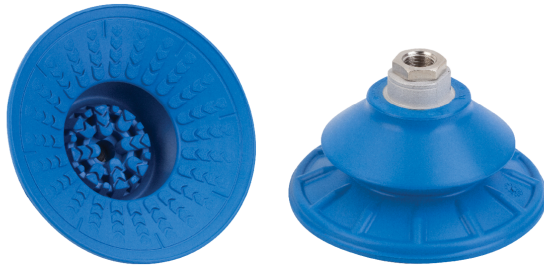

Bellows Suction Cups SAB HT1 (1.5 Folds)

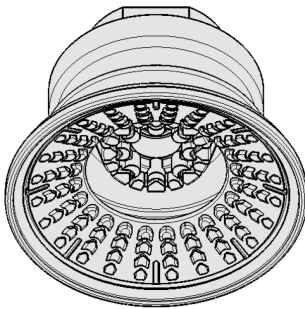

System design Bellows Suction Cups SAB HT1 (1.5 Folds)

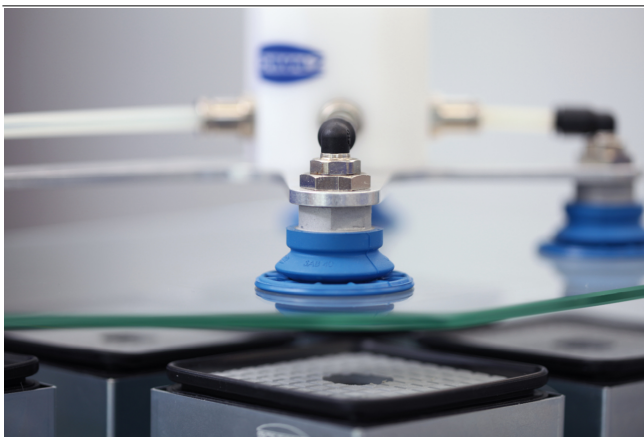

Bellows suction cups SAB HT1 being used for handling glass

### Suitability for industry specific applications

#### Applications

- Round bellows suction cup with 1.5 folds for dynamic handling of glass workpieces
- Handling of flat glass and formed glass pieces
- Use in automated production lines for automotive glasses such as windscreens and side windows, even after the bending process at temperatures up to 170 °C
- Precise positioning of flat glass in the production process due to displacement-free handling
- High lateral forces in use with separation powder on flat glass or on damp surfaces

#### Design

- Robust and wear-resistant bellows suction cup made of HT1 with 1.5 folds
- Connection nipple vulcanized to elastomer part (for very high strength)
- Special structure of the suction surface with high performance profile

#### Product highlights

- Minimal chemical influence on the workpiece surface thanks to the non-marking special material HT1
- Handling of hot workpieces thanks to high temperature resistance
- Structured inner support withstands the highest lateral forces, especially when used with separation powder and on wet workpieces

## Bellows Suction Cups SAB HT1 (1.5 Folds)

Suction area ( $\emptyset$ ) from 22 mm to 125 mm

### Designation code Bellows Suction Cups SAB HT1 (1.5 Folds)

<b>SAB</b>	–	<b>30</b>	–	<b>HT1-60</b>	–	<b>G1/4-AG</b>
<b>1</b>		<b>2</b>		<b>3</b>		<b>4</b>

#### 1 – Abbreviated designation

Code	Version
SAB	1.5 folds

#### 2 – Suction area

Code	Diameter in mm
22...125	$\emptyset$ 22 to 125

#### 3 – Material

Code	Material
HT1-60	High temperature material

#### 4 – Connection

Code	Connection
G1/4-AG	G1/4-AG (AG = male (M))
G1/4-IG	G1/4-IG (IG = female (F))
G3/8-AG	G3/8-AG
G3/8-IG	G3/8-IG
RA	Rectangular adapter

Suction cup SAB HT1, available in various diameters, is delivered with connection nipple vulcanized to elastomer part.

### Ordering data Bellows Suction Cups SAB HT1 (1.5 Folds)

Type		Vacuum connection:				Rectangular adapter
		G1/4"-M	G1/4"-F	G3/8"-M	G3/8"-F	
SAB	22	10.01.06.02753	10.01.06.02722	10.01.06.03015	10.01.06.03006	-
SAB	30	10.01.06.03048	10.01.06.02723	10.01.06.03049	10.01.06.03050	10.01.06.02755
SAB	40	10.01.06.03051	10.01.06.02724	10.01.06.03052	10.01.06.03053	10.01.06.02757
SAB	50	10.01.06.03057	10.01.06.02760	10.01.06.03058	10.01.06.02725	10.01.06.02759
SAB	60	10.01.06.03059	10.01.06.02779	10.01.06.03060	10.01.06.02726	10.01.06.02762
SAB	80	10.01.06.03061	10.01.06.02778	10.01.06.03062	10.01.06.02727	10.01.06.02764
SAB	100	10.01.06.02927	10.01.06.02961	10.01.06.03063	10.01.06.02728	10.01.06.02766
SAB	125	10.01.06.03065	10.01.06.03064	10.01.06.03066	10.01.06.02729	-

### Technical data Bellows Suction Cups SAB HT1 (1.5 Folds)

Type		Suction force (-600 mbar) [N]*	Pull-off force [N]	Lateral force [N]**	Volume [cm <sup>3</sup> ]	Workpiece radius min. (convex) [mm]	Hose diameter (recom.) d [mm]***
SAB	22	16	24	18	1.5	20	4
SAB	30	22	33	30	5.6	40	4
SAB	30	22	33	30	5.9	40	4
SAB	40	38	59	36	8.7	40	4
SAB	40	38	59	36	7.0	40	4
SAB	50	53	87	55	16.1	50	4
SAB	60	82	130	82	28.8	65	6
SAB	80	135	221	145	67.6	75	6
SAB	100	190	357	220	115.0	90	6
SAB	125	250	558	352	220.0	140	9

\*The specified suction forces are theoretical values at a vacuum of -0.6 bar and with a smooth, dry workpiece surface - they do not include a safety factor

\*\*The specified lateral forces are values measured at a vacuum of -0.6 bar with a dry, smooth, flat workpiece surface. Depending on the workpiece surface and its quality, the actual values may deviate from these values.

\*\*\*The recommended hose diameter is based on a hose length of approx. 2 m

# Bellows Suction Cups SAB HT1 (1.5 Folds)

Suction area ( $\emptyset$ ) from 22 mm to 125 mm

## Design data Bellows Suction Cups SAB HT1 (1.5 Folds)

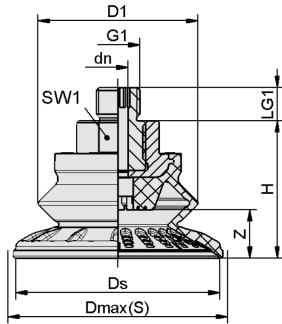

SAB HT1 AG

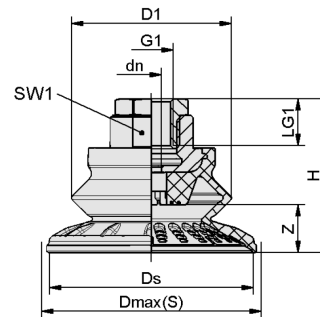

SAB HT1 IG

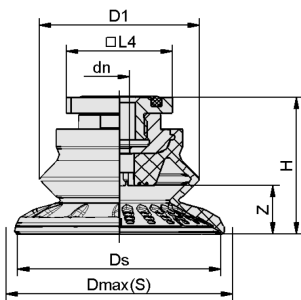

SAB HT1 RA

## Bellows Suction Cups SAB HT1 (1.5 Folds)

Suction area (Ø) from 22 mm to 125 mm

### Design data Bellows Suction Cups SAB HT1 (1.5 Folds)

Type*	D1 [mm]	dn [mm]	Dmax(S) [mm]**	Ds [mm]	G1	H [mm]	LG1 [mm]	L4 [mm]	SW1 [mm]	Z (Stroke) [mm]
SAB 22 HT1-60 G1/4-AG	22	3.5	24	21	G1/4"-M	25.0	10.0	-	16	5.8
SAB 22 HT1-60 G1/4-IG	22	3.5	24	21	G1/4"-F	25.0	12.0	-	16	5.8
SAB 22 HT1-60 G3/8-AG	22	3.5	24	21	G3/8"-M	25.0	10.0	-	16	5.8
SAB 22 HT1-60 G3/8-IG	22	3.5	24	21	G3/8"-F	41.0	9.5	-	22	5.8
SAB 30 HT1-60 G1/4-AG	32	4.0	34	31	G1/4"-M	28.0	10.0	-	17	9.0
SAB 30 HT1-60 G1/4-IG	32	4.0	34	31	G1/4"-F	28.0	12.0	-	17	9.0
SAB 30 HT1-60 G3/8-AG	32	4.0	34	31	G3/8"-M	28.0	10.0	-	17	9.0
SAB 30 HT1-60 G3/8-IG	32	4.0	34	31	G3/8"-F	44.0	9.5	-	22	9.0
SAB 30 HT1-60 RA	32	4.0	34	31	-	31.2	-	31.8	-	9.0
SAB 40 HT1-60 G1/4-AG	32	4.0	45	41	G1/4"-M	28.8	10.0	-	17	10.0
SAB 40 HT1-60 G1/4-IG	32	4.0	45	41	G1/4"-F	28.8	12.0	-	17	10.0
SAB 40 HT1-60 G3/8-AG	32	4.0	45	41	G3/8"-M	28.8	10.0	-	17	10.0
SAB 40 HT1-60 G3/8-IG	32	4.0	45	41	G3/8"-F	44.8	9.5	-	22	10.0
SAB 40 HT1-60 RA	32	4.0	45	41	-	31.2	-	31.8	-	10.0
SAB 50 HT1-60 G1/4-AG	40	6.0	56	51	G1/4"-M	36.9	10.0	-	22	11.5
SAB 50 HT1-60 G1/4-IG	40	6.0	56	51	G1/4"-F	42.0	20.0	-	22	11.5
SAB 50 HT1-60 G3/8-AG	40	6.0	56	51	G3/8"-M	36.9	10.0	-	22	11.5
SAB 50 HT1-60 G3/8-IG	40	6.0	56	51	G3/8"-F	36.9	15.0	-	22	11.5
SAB 50 HT1-60 RA	40	6.0	56	51	-	36.6	-	31.8	-	11.5
SAB 60 HT1-60 G1/4-AG	48	6.0	67	62	G1/4"-M	41.3	10.0	-	22	14.5
SAB 60 HT1-60 G1/4-IG	48	6.0	67	62	G1/4"-F	46.3	20.0	-	22	14.5
SAB 60 HT1-60 G3/8-AG	48	6.0	67	62	G3/8"-M	41.3	10.0	-	22	14.5
SAB 60 HT1-60 G3/8-IG	48	6.0	67	62	G3/8"-F	41.3	15.0	-	22	14.5
SAB 60 HT1-60 RA	48	6.0	67	62	-	41.0	-	31.8	-	14.5
SAB 80 HT1-60 G1/4-AG	64	6.0	89	82	G1/4"-M	49.9	10.0	-	22	22.1
SAB 80 HT1-60 G1/4-IG	64	6.0	89	82	G1/4"-F	54.9	20.0	-	22	22.1
SAB 80 HT1-60 G3/8-AG	64	6.0	89	82	G3/8"-M	49.9	10.0	-	22	22.1

## Bellows Suction Cups SAB HT1 (1.5 Folds)

Suction area (Ø) from 22 mm to 125 mm

Type*	D1 [mm]	dn [mm]	Dmax(S) [mm]**	Ds [mm]	G1	H [mm]	LG1 [mm]	L4 [mm]	SW1 [mm]	Z (Stroke) [mm]
SAB 80 HT1-60 G3/8-IG	64	6.0	89	82	G3/8"-F	49.9	15.0	-	22	22.1
SAB 80 HT1-60 RA	64	6.0	89	82	-	49.6	-	31.8	-	22.1
SAB 100 HT1-60 G1/4- AG	77	6.0	110	101	G1/4"-M	56.6	10.0	-	22	25.8
SAB 100 HT1-60 G1/4-IG	77	6.0	110	101	G1/4"-F	61.8	20.0	-	22	25.8
SAB 100 HT1-60 G3/8- AG	77	6.0	110	101	G3/8"-M	56.6	10.0	-	22	25.8
SAB 100 HT1-60 G3/8-IG	77	6.0	110	101	G3/8"-F	56.6	15.0	-	22	25.8
SAB 100 HT1-60 RA	77	6.0	110	101	-	56.3	-	31.8	-	25.8
SAB 125 HT1-60 G1/4- AG	94	6.0	135	126	G1/4"-M	67.8	10.0	-	22	32.0
SAB 125 HT1-60 G1/4-IG	94	6.0	135	126	G1/4"-F	72.8	20.0	-	22	32.0
SAB 125 HT1-60 G3/8- AG	94	6.0	135	126	G3/8"-M	67.8	10.0	-	22	32.0
SAB 125 HT1-60 G3/8-IG	94	9.0	135	126	G3/8"-F	67.8	15.0	-	22	32.0

\*Acceptable dimensional tolerances for rubber parts concerning to DIN ISO 3302-1 E3

\*\*External dimension of the suction cup when it is pressed against the workpiece by the vacuum