

Operating Instructions

Vacuum Block VCBL-HD-K1/K2

Note

The Operating instructions were originally written in German. Store in a safe place for future reference. Subject to technical changes without notice. No responsibility is taken for printing or other types of errors.

Published by

© J. Schmalz GmbH, 05/23

This document is protected by copyright. J. Schmalz GmbH retains the rights established thereby. Reproduction of the contents, in full or in part, is only permitted within the limits of the legal provisions of copyright law. Any modifications to or abridgments of the document are prohibited without explicit written agreement from J. Schmalz GmbH.

J. Schmalz GmbH · Johannes-Schmalz-Str. 1 · 72293 Glatten, Germany · T: +49 7443 2403-0
schmalz@schmalz.de

1 Important Information

1.1 Note on Using this Document

J. Schmalz GmbH is generally referred to as Schmalz in this document.

The document contains important notes and information about the different operating phases of the product:

- Transport, storage, start of operations and decommissioning
- Safe operation, required maintenance, rectification of any faults

The document describes the product at the time of delivery by Schmalz and is aimed at:

- Installers who are trained in handling the product and can operate and install it
- Technically trained service personnel performing the maintenance work
- Technically trained persons who work on electrical equipment

1.2 The technical documentation is part of the product

1. For problem-free and safe operation, follow the instructions in the documents.
 2. Keep the technical documentation in close proximity to the product. The documentation must be accessible to personnel at all times.
 3. Pass on the technical documentation to subsequent users.
- ⇒ Failure to follow the instructions in these Operating instructions may result in injuries!
- ⇒ Schmalz is not liable for damage or malfunctions that result from failure to heed these instructions.

If you still have questions after reading the technical documentation, contact Schmalz Service at: www.schmalz.com/services

1.3 Warnings in This Document

Warnings warn against hazards that may occur when handling the product. This document contains three levels of danger that you can recognize by the signal word.

Signal word	Meaning
WARNING	Indicates a medium-risk hazard that could result in death or serious injury if not avoided.
CAUTION	Indicates a low-risk hazard that could result in minor or moderate injury if not avoided.
NOTE	Indicates a danger that leads to property damage.

1.4 Symbols



This symbol indicates useful and important information.

- ✓ This symbol represents a prerequisite that must be met before an action is performed.
- ▶ This symbol represents an action to be performed.
- ⇒ This symbol represents the result of an action.

Actions that consist of more than one step are numbered:

1. First action to be performed.
2. Second action to be performed.

2 Fundamental Safety Instructions

2.1 Intended Use

The vacuum block VCBL-HD is built in accordance with the latest standards of technology and is delivered in a safe operating condition; however, hazards may arise during use.

The VCBL-HD-K1/K2 series of vacuum blocks is used for clamping workpieces (optimized for solid wood) on the processing machine and is placed on the machine table with specially designed consoles.

For correct use, the consoles must be constructed as follows:

- Single-circuit consoles (K1) have a row of valves and a width of 115 mm at the top and a dovetail with a 30° slope at the bottom.
- Two-circuit brackets (K2) have two rows of valves at the top. The consoles have a width of 115 mm at the top.

Depending on the console system (single-circuit, two-circuit), the individual vacuum block types are used as follows:

The product is intended for use in the areas of industry, trade, and handcraft.

Intended use includes observing the technical data and the installation and operating instructions in this manual.

2.2 Non-Intended Use

Schmalz accepts no liability for damages resulting from use other than as intended. In particular, the following are considered non-intended use:

- Operation of the vacuum block with worn or damaged suction plate or sealing gasket
- Suction of human or animal body parts
- Machining forces that lead to the vacuum block and/or workpiece being displaced or torn off are not permitted.
- Use of the vacuum block as a base, support or comparable aid
- Evacuation of highly inflammable or explosive media
- Contact with liquids, media or surfaces that lead to a reduction in the static friction or vacuum force of the suction cup
- Operation with a workpiece that does not cover the entire suction plate
- Attach the vacuum block
 - when the vacuum is switched on
 - at an angle on the console
 - with the top facing the console.

2.3 Personnel Qualifications

Unqualified personnel cannot recognize dangers and are therefore exposed to higher risks!

1. Task only qualified personnel to perform the tasks described in these Operating instructions.
2. The product must be operated only by persons who have undergone appropriate training.

These Operating instructions are intended for fitters who are trained in handling the product and who can operate and install it.

2.4 Workplace Requirements

The following requirements must be fulfilled to ensure a safe workplace:

- The Vacuum block must not be used outdoors.
- The type plate and warning signs must be legible.
- The surroundings of the Vacuum block must be dry.
- The operator must have a clear view of the whole working area, the workplace must be adequately lit and free of glare, and the area around the workplace must be clean and clear.

2.5 Emissions

The Vacuum block emits noise as a result of operating with vacuum.



CAUTION

Noise pollution from leakage

Hearing damage

- ▶ Correct position.
 - ▶ Wear ear protectors.
-

2.6 Modifications to the Product

Schmalz assumes no liability for consequences of modifications over which it has no control:

1. The product must be operated only in its original condition as delivered.
2. Use only original spare parts from Schmalz.
3. The product must be operated only in perfect condition.

3 Design of the Vacuum Block

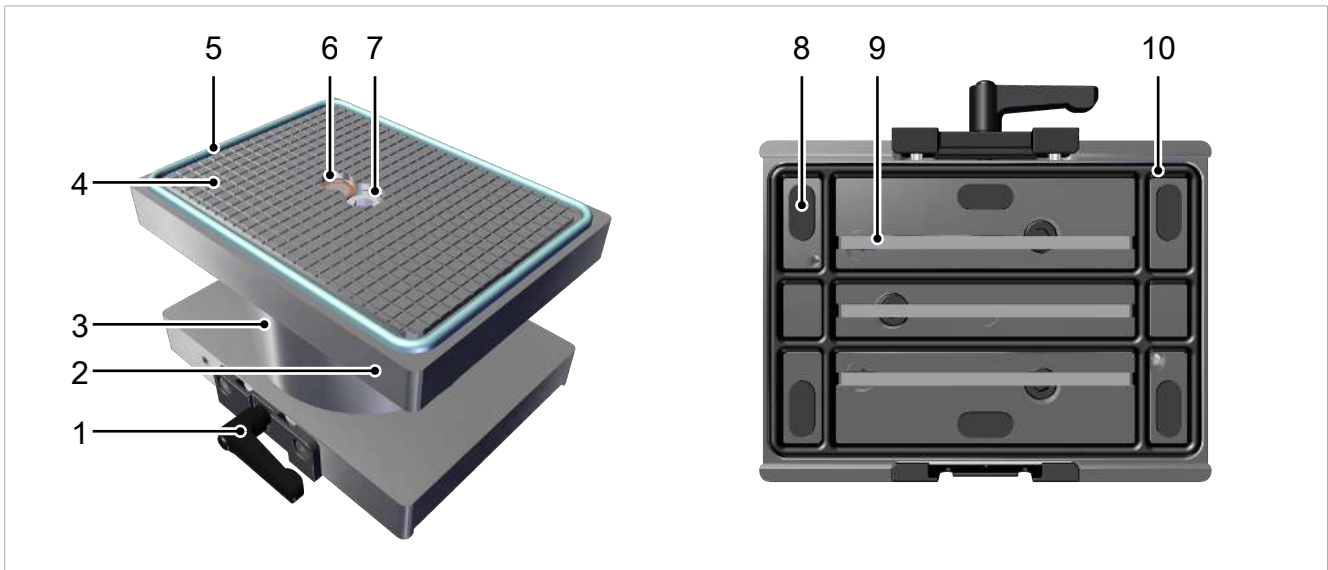

1	Clamping	6	Screen/optional touch valve
2	Suction plate	7	Adjusting screw (suction plate adjustment)
3	Aluminum body	8	Support/friction disc
4	Friction pad	9	Metal strip
5	Sealing	10	Sealing frame

3.1 Rotating the Suction Plate

The central screw (7) is used to attach the suction plate.

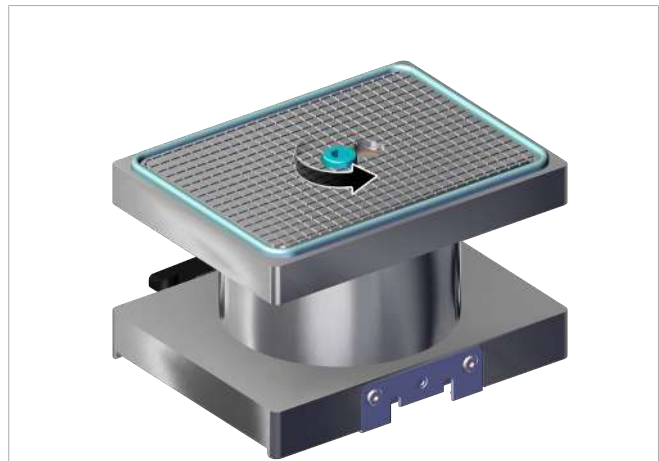

- ▶ You can loosen this screw using a hex key (SW8). When you unscrew it by about 1 cm ...

- ▶ ... the suction plate can be lifted and rotated in 15° increments.

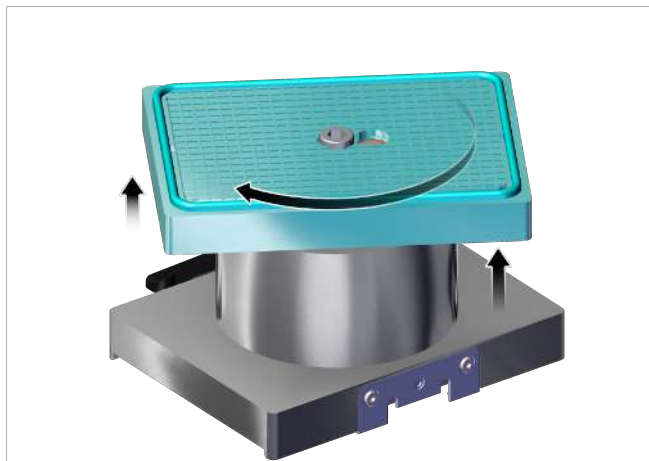

- ▶ Then tighten the screw again with the specified torque of 30 Nm.

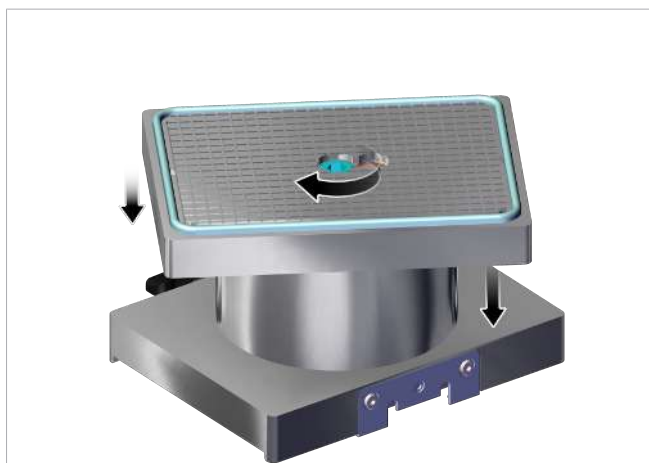

4 Technical Data

4.1 General Parameters

Parameter	Unit	Value
Maximum ambient temperature	°C	5 ... 45

4.2 Dimensions

Variants: VCBL-HD ..., height: 100

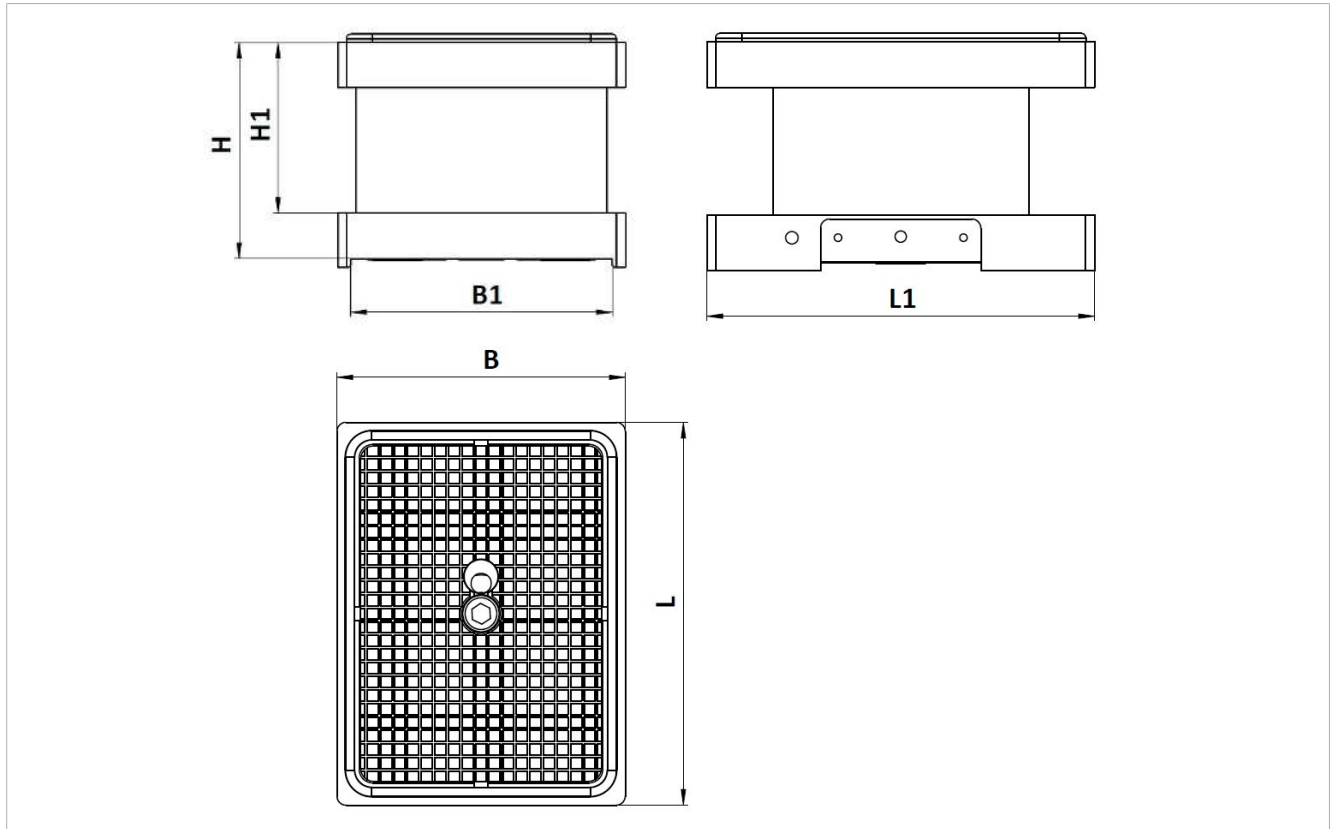

Part no.	L	B	H	L1	B1	H1
10.01.12.05228	75	128	100	170	116	78.8
10.01.12.05221	170					
10.01.12.05311	60					
10.01.12.05274	75					
10.01.12.05273	170					
10.01.12.05312	60					
10.01.12.05281	75					
10.01.12.05282	170					
10.01.12.05317	60					
10.01.12.05283	75					
10.01.12.05284	170					
10.01.12.05317	60					

Variants: VCBL-HD ..., height: 125

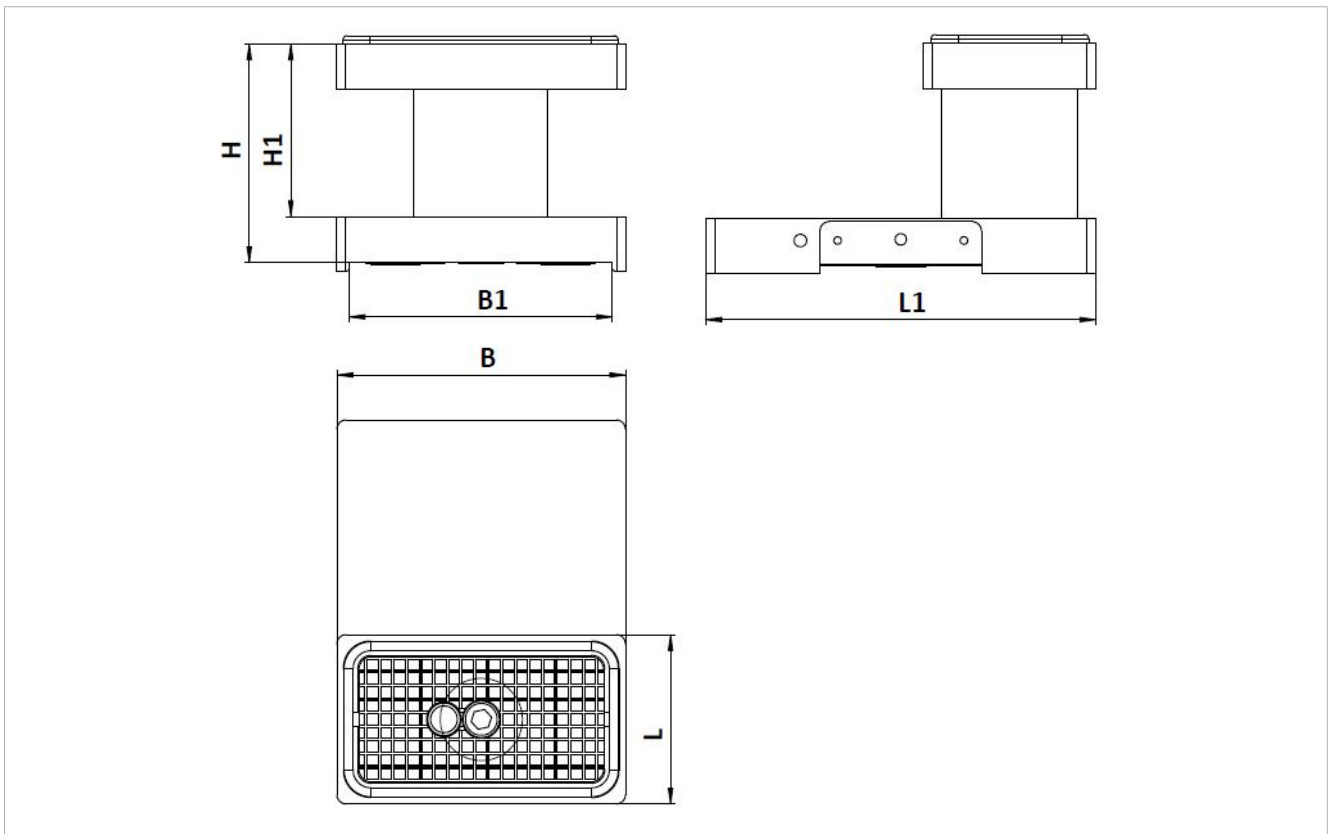

Part no.	L	B	H	L1	B1	H1
10.01.12.05319	75	128	125	170	116	103.8
10.01.12.05320	170					
10.01.12.05321	60					
10.01.12.05322	75					
10.01.12.05323	170					
10.01.12.05324	60					
10.01.12.05325	75					
10.01.12.05327	170					
10.01.12.05326	60					
10.01.12.05328	75					
10.01.12.05330	170					
10.01.12.05329	60					

All specifications are in mm.

5 Transportation and Storage

5.1 Checking the Delivery

The scope of delivery can be found in the order confirmation. The weights and dimensions are listed in the delivery notes.

1. Compare the entire delivery with the supplied delivery notes to make sure nothing is missing.
2. Damage caused by defective packaging or occurring in transit must be reported immediately to the carrier and J. Schmalz GmbH.

6 Installation

6.1 Installation Instructions



⚠ CAUTION

Vacuum close to the eye

Severe eye injury!

- ▶ Wear eye protection.
- ▶ Do not look into vacuum openings, e.g. suction cups.

For safe installation, the following instructions must be observed:

- Dirt particles or foreign bodies in the suction plate connections, hoses or pipelines can lead to malfunctions or failure.
- Mounting and removal may be performed only when the device is unpressurized and disconnected from the mains.

6.2 Placing the Vacuum Block on the Console

Variant with single-circuit system

1. Place the vacuum block on the vacuum console aslant as shown in the picture **1**. Ensure that the guide strip reaches underneath the bevel of the vacuum console. Swivel the vacuum block onto the vacuum console **2** and position it over a vacuum opening. If necessary, use the clamping lever to open the clamping unit so that the fixing flap fits over the edge of the vacuum console.

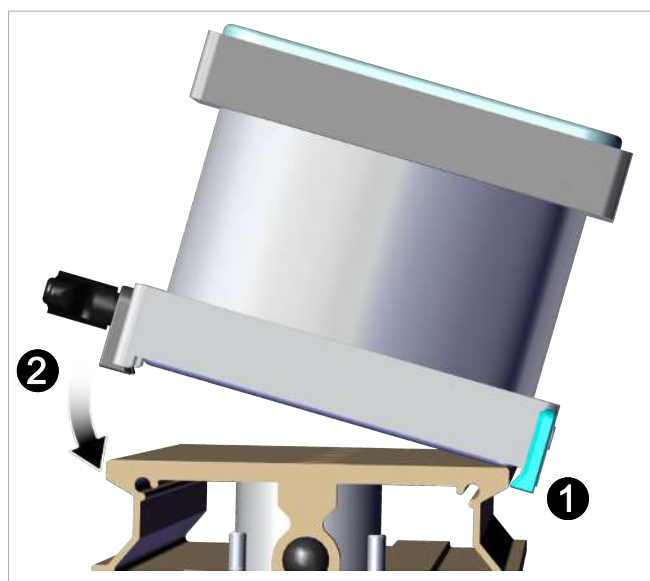

⇒ The solenoid valve integrated into the vacuum console (for the vacuum supply) is opened by the VCBL-HD-K1.

2. Tighten the clamping lever (hand-tight) to pre-fix the vacuum block to the vacuum console.

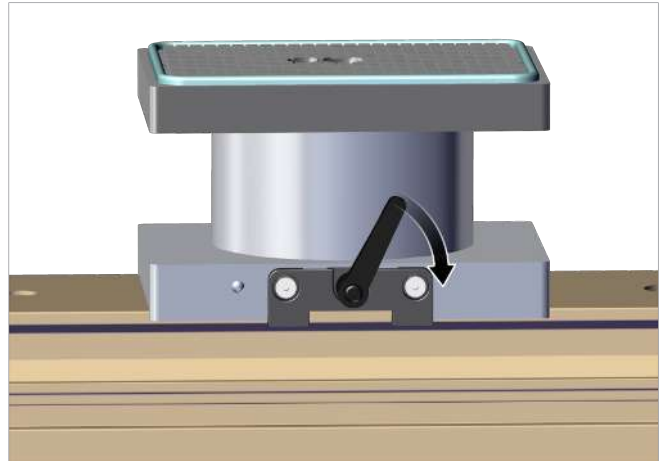

Variant with two-circuit system

- ▶ Place the vacuum block onto the vacuum console and position it over a vacuum opening as shown in the picture.

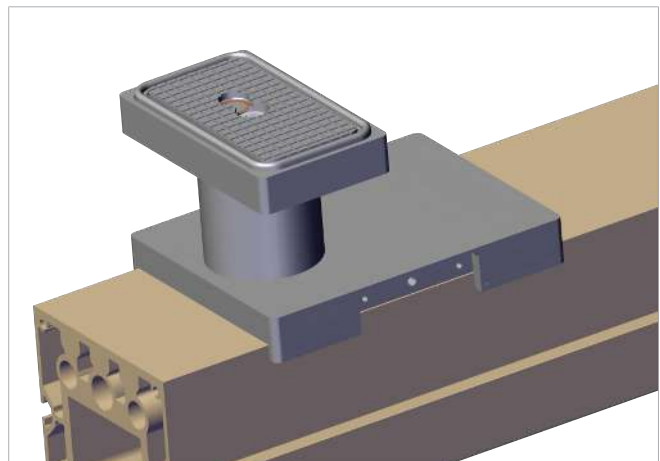

- ⇒ The vacuum block should be in full contact with the vacuum console and fitted over the side edges.
- ⇒ The solenoid valves integrated into the vacuum console (for the vacuum supply) are opened by the VCBL-HD-K2.

The Vacuum block is not fixed in place. Evacuating the corresponding vacuum circuit of the console and thus the area between the Vacuum block and the console produces the clamping force required for fixing.

7 Specifications for Use



⚠ CAUTION

During machining, dust is released into the environment and can enter the respiratory tract.

Danger to health

- ▶ Use suction equipment or cover the machining area to ensure that no dust is released into the environment.
- ▶ If necessary, wear a breathing mask in accordance with class FFP1 or higher.

1. Monitor the vacuum value that is reached as close as possible to the vacuum block (e.g. with a gauge).
2. Ensure that the operating vacuum is ≥ 600 mbar before machining the workpiece.
3. Before each machining process, clean chips and dust from the console and vacuum block to achieve the required accuracy and adhesion as well as to prevent leakage.
4. Check the sealing gasket and sealing frame for wear and replace if necessary.

8 Using the Vacuum Blocks

Depending on the console system (single-circuit, two-circuit), the individual vacuum block types are used as follows:

- Single-circuit console (VCBL-HD-K1)
 - Vacuum blocks for single-circuit consoles are pre-fixed using mechanical clamps when placed on the console. By switching on the operating vacuum and placing the workpiece on the vacuum block, the workpiece is fixed on the vacuum block, as is the vacuum block on the console. By switching off the operating vacuum, the workpiece is released and the fixing of the vacuum block on the console is also released. The pre-fixing (mechanical clamp) is retained.
 - Two-circuit console (VCBL-HD-K2)
 - Vacuum blocks for two-circuit consoles are fixed to the console by supplying operating vacuum at the first vacuum circuit. By switching on the operating vacuum at the second vacuum circuit, the workpiece placed on the vacuum block is fixed. By switching off the second vacuum circuit, the workpiece is released and the vacuum block remains fixed. When switching off the first vacuum circuit, the vacuum block is released from the console. You can also optionally attach a mechanical clamping device here. In addition to the first vacuum circuit, this serves as a fixing.
- ▶ Before starting the machining process, check that the vacuum block(s) and workpiece are securely fastened.

9 Machining Limitations



⚠ WARNING

The workpiece comes loose during machining and is flung away by the machine.

Risk of injury from flying parts.

- ▶ Ascertain the maximum machining parameters and observe them.

The holding force is limited, meaning that it can withstand machining forces only up to a certain point. Accordingly, the operator of the vacuum block is obligated to establish for themselves (by experiment, slowly and carefully increasing the machining forces) the optimal settings and number of vacuum blocks necessary to ensure that the workpiece does not slip or even come loose during the machining process.

This procedure should be performed in particular for new workpieces that have never been machined before or for uncertain cases with regard to the holding force.

Schmalz assumes no liability for damages resulting from slippage or release of workpieces due to faulty adjustment of machining parameters.

10 Troubleshooting

Malfunction	Cause	Troubleshooting
No vacuum on the clamping equipment or vacuum is too low	Vacuum generator does not start	▶ Switching on the vacuum generator
	Vacuum for clamping system not released	▶ Release "Clamp workpiece" vacuum for clamping device
	Leakage	<ol style="list-style-type: none"> 1. Check the clamping device for leakage. 2. Ensure that the clamping equipment is complete (sealing) 3. Remove dirt
	Closed vacuum system	▶ Remove dirt

11 Warranty

Schmalz guarantees this system pursuant to our General Terms and Conditions of Sale and Delivery. The same applies to spare parts, provided that these are original parts supplied by us.

Wearing parts are not covered by the warranty.

12 Cleaning the Vacuum Blocks

1. For cleaning, do not use aggressive cleaning agents such as industrial alcohol, white spirit or thinners.
2. Remove dirt on the exterior of the device with a soft cloth and soap suds.

13 Spare and wearing parts

Part no.	Type	Designation	Type
10.01.12.05310	SPT 128x60 AL	Suction plate, 128x60	Wearing part
10.01.12.05232	SPT 128x75 AL	Suction plate 128x75	Wearing part
10.01.12.05226	SPT 170x128 AL	Suction plate 170x128	Wearing part
10.01.12.03629	VCDR 166x113x6.6 VCSP	Foam sealing frame (bottom) for VCBL-HD K1	Wearing part
10.01.12.02191	VCDR 166x113x6.6 VCSP	Foam sealing frame (bottom) for VCBL-HD K2	Wearing part
10.07.08.00073	O-ring	O-ring, suction plate	Spare part
10.07.01.00211	Screen, round	Screen	Spare part
10.01.12.02514	TV D9	Touch valve	Spare part
20.01.02.02003	SCHR 4762 M10x30	Cylinder head screw, M10	Spare part
10.01.12.04255	Clamping unit VCMC-K2	Clamping set K2	Spare part
10.01.12.04835	Clamping unit VCMC-K1	Clamping set K1	Spare part

14 Disposing of the product

- ▶ Sort and dispose of all components according to the country-specific regulations.



For proper disposal, please contact a company specializing in the disposal of technical goods and instruct the company to observe the applicable disposal and environmental regulations. Schmalz is happy to assist you in finding a suitable company.

15 Notes

At Your Service Worldwide



Vacuum automation

WWW.SCHMALZ.COM/AUTOMATION

Handling systems

WWW.SCHMALZ.COM/EN-US/VACUUM-LIFTERS-AND-CRANE-SYSTEMS

J. Schmalz GmbH
Johannes-Schmalz-Str. 1
72293 Glatten, Germany
T: +49 (0) 7443 2403-0
schmalz@schmalz.de
WWW.SCHMALZ.COM