



Assembly instructions

Vacuum Generator ECBPMi MATCH

Note

The Assembly instructions were originally written in German. Store in a safe place for future reference. Subject to technical changes without notice. No responsibility is taken for printing or other types of errors.

Published by

© J. Schmalz GmbH, 12/22

This document is protected by copyright. J. Schmalz GmbH retains the rights established thereby. Reproduction of the contents, in full or in part, is only permitted within the limits of the legal provisions of copyright law. Any modifications to or abridgments of the document are prohibited without explicit written agreement from J. Schmalz GmbH.

Contents

1	Important Information	4
1.1	Note on Using this Document	4
1.2	The technical documentation is part of the product	4
1.3	Other Applicable Documents	4
1.4	Type Plate	4
1.5	Symbols	5
2	Fundamental Safety Instructions	5
2.1	Intended Use	5
2.2	Non-Intended Use	5
2.3	Personnel Qualification	6
2.4	Warnings in This Document	6
2.5	Personal Protective Equipment	6
2.6	Residual Risks	6
2.7	Modifications to the Product	7
2.8	Criteria for Use in Collaborative Applications	7
3	Product Description	8
3.1	Compatible Quick-Change Modules RMQC End-of-Arm Ecosystem MATCH	8
3.2	Included in Delivery with ECBPMi MATCH	9
4	Storage Station (Accessories)	9
5	Technical Data	11
5.1	General Parameters	11
5.2	Tool-Changer-Specific Data	11
5.3	Static Load Limits	11
5.4	Dimensions	12
6	Transportation and Storage	13
6.1	Checking the Delivery	13
6.2	Unpacking the Device	13
6.3	Transport / Storage / Preservation	13
7	Installation	14
7.1	Installation Instructions	14
7.2	Mounting of RMQC Fixed Member and RMQC Loose Member	15
7.3	Electrical Connection	16
7.4	Static Electricity	16
8	Operation	16
8.1	Preparations	16
8.2	Hot-Plug Function	17
9	Maintenance and Cleaning	17
9.1	Safety Instructions for Maintenance	17
9.2	Maintenance	17
10	Spare and Wearing Parts, Accessories	18

10.1	Spare and Wearing Parts.....	18
10.2	Accessories.....	18
11	Taking the Product Out of Operation and Disposal.....	19
12	Declarations of Conformity.....	19
12.1	EU Declaration of Incorporation.....	19
12.2	EC Conformity.....	20
12.3	UKCA Declaration of Incorporation	20
12.4	UKCA Conformity	21

1 Important Information

1.1 Note on Using this Document

J. Schmalz GmbH is generally referred to as Schmalz in this document.

The document contains important notes and information about the different operating phases of the product:

- Transport, storage, start of operations and decommissioning
- Safe operation, required maintenance, rectification of any faults

The document describes the product at the time of delivery by Schmalz and is aimed at:

- Installers who are trained in handling the product and can operate and install it
- Technically trained service personnel performing the maintenance work
- Technically trained persons who work on electrical equipment

1.2 The technical documentation is part of the product

1. For problem-free and safe operation, follow the instructions in the documents.
2. Keep the technical documentation in close proximity to the product. The documentation must be accessible to personnel at all times.
3. Pass on the technical documentation to subsequent users.
 - ⇒ Failure to follow the instructions in these Assembly instructions may result in injuries!
 - ⇒ Schmalz is not liable for damage or malfunctions that result from failure to heed these instructions.

If you still have questions after reading the technical documentation, contact Schmalz Service at:

www.schmalz.com/services

1.3 Other Applicable Documents

When using the Rob-Set ECBPMi MATCH, the following technical documentation must also be observed:

Technical documentation	Part number
Operating Instructions for the Quick-Change Module RMQC End-of-Arm Ecosystem MATCH	30.30.01.02732
Operating Instructions for Vacuum Generator ECBPMi	30.30.01.02196
Assembly Instructions for the Storage Station MATCH	30.30.01.02781
Operating Instructions for the SCM Module	30.30.01.02782

1.4 Type Plate

The type plate (1) is permanently attached to the product at the location shown and must always be clearly legible.

It contains important information about the product.

- Name
- Part number
- Manufacturing date
- Serial number
- QR code
- CE label
- EAC label



Please specify all the information above when ordering replacement parts, making warranty claims or for any other inquiries.

1.5 Symbols



This symbol indicates useful and important information.

- ✓ This symbol represents a prerequisite that must be met prior to an operational step.
- ▶ This symbol represents an action to be performed.
- ⇒ This symbol represents the result of an action.

Actions that consist of more than one step are numbered:

1. First action to be performed.
2. Second action to be performed.

2 Fundamental Safety Instructions

2.1 Intended Use

The vacuum generator ECBPMi MATCH is used to generate an electrical vacuum in order to use vacuum suction cups to grip objects and then to transport them. The product was specially developed for use on collaborative robot systems and in conjunction with the quick-change system MATCH. The product is intended for use in enclosed spaces for time-limited gripping, handling and holding applications.

The goods to be lifted should ideally be dry, airtight, rigid and have a smooth surface. Non-airtight or unstable objects must be tested for suitability before they are handled with a vacuum. Contamination of the products can impair their functionality.

Neutral gases in accordance with EN 983 are approved as evacuation media. Neutral gases include air, nitrogen and inert gases (e.g. argon, xenon and neon).

The product is built in accordance with the latest standards of technology and is delivered in a safe operating condition; however, hazards may arise during use.

The product is intended for industrial use.

Intended use includes observing the technical data and the installation and operating instructions in this manual.

The device may only be used with robot systems that comply with the provisions of DIN ISO/TS 15066, DIN EN ISO 10218-1 and DIN EN ISO 10218-2.

Operation as part of a collaborative system is only permitted when the entire system meets the corresponding legal requirements for collaborative robot systems. The system integrator is responsible for ensuring that these requirements are complied with.

2.2 Non-Intended Use

Schmalz does not accept any liability for any direct or indirect losses or damages that result from using the product. This applies, in particular, to any use of the product that is not in accordance with the intended purpose and to any use that is not described or mentioned in this documentation.

In particular, the following are considered non-intended use:

1. Use in potentially explosive atmospheres
2. Lifting people or animals
3. Use for medical applications
4. Storing loads while picked up
5. Supporting the lifting process by applying external forces
6. Applying suction to building components, equipment or supporting surfaces.
7. Evacuation of objects that are in danger of imploding
8. Unauthorized refits
9. Use as a clamping device for workpiece processing
10. Direct contact with perishable goods/food products

2.3 Personnel Qualification

Unqualified personnel cannot recognize dangers and are therefore exposed to higher risks!

The operating company must ensure the following points:



- The personnel must be commissioned for the activities described in these operating instructions.
- The staff must be at least 18 years of age and physically and mentally capable.
- The operating staff have been instructed in the operation of the product and have read and understood the operating instructions.
- Installation, maintenance, and repairs must be carried out only by specialists or by persons who can prove that they have undergone appropriate training.

Applicable for Germany:

A qualified employee is defined as an employee who has received technical training and has the knowledge and experience – including knowledge of applicable regulations – necessary to enable him or her to recognize possible dangers and implement the appropriate safety measures while performing tasks. Qualified employees must observe the relevant industry-specific rules and regulations.

2.4 Warnings in This Document

Warnings warn against hazards that may occur when handling the product. The signal word indicates the level of danger.

Signal word	Meaning
 WARNING	Indicates a medium-risk hazard that could result in death or serious injury if not avoided.
 CAUTION	Indicates a low-risk hazard that could result in minor or moderate injury if not avoided.
NOTE	Indicates a danger that leads to property damage.

2.5 Personal Protective Equipment

Always use suitable and appropriate protective equipment that suits the situation to avoid injury:

- Eye protection (class F)
- Hair net
- Closely fitting clothing

2.6 Residual Risks



WARNING

Electric shock

Risk of injury

- ▶ Operate the product using a power supply unit with protected extra-low voltage (PELV).



CAUTION

Falling product

Risk of injury

- ▶ Fasten or store the product securely at the location of use.
- ▶ Wear protective work shoes (S1).



⚠ CAUTION

Compressed air or vacuum in direct contact with the eye

Severe eye injury

- ▶ Wear eye protection
- ▶ Do not look into compressed air openings
- ▶ Do not look into the silencer air stream
- ▶ Do not look into vacuum openings, e.g. suction cups



⚠ CAUTION

Depending on the purity of the ambient air, the exhaust air can contain particles, which escape from the exhaust air outlet at high speed.

Eye injuries!

- ▶ Do not look into the exhaust air flow.
- ▶ Wear eye protection.

2.7 Modifications to the Product

Schmalz assumes no liability for consequences of modifications over which it has no control:

1. The product must be operated only in its original condition as delivered.
2. Use only original spare parts from Schmalz.
3. The product must be operated only in perfect condition.

2.8 Criteria for Use in Collaborative Applications

The following criteria justify the suitability of the gripper for use in collaborative applications:

See the adjacent image, Figure 3) and 4). The gripper has an inherently safe design and rounded edges and shapes that prevent hazards.

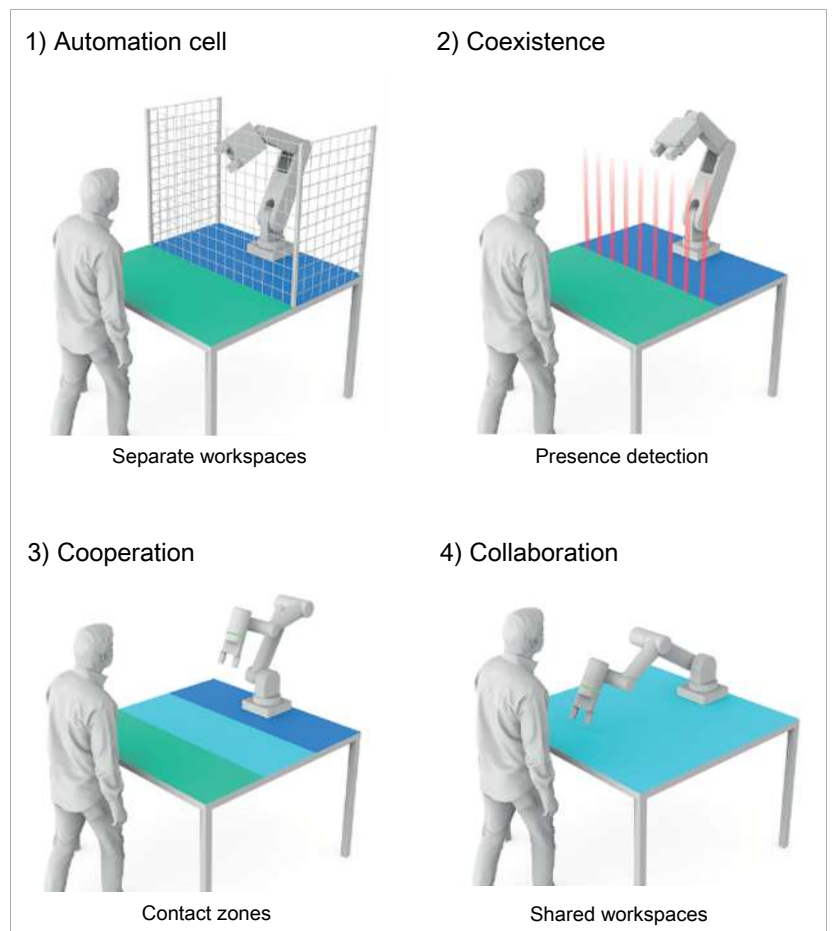

3 Product Description

3.1 Compatible Quick-Change Modules RMQC | End-of-Arm Ecosystem MATCH

Schmalz part no.	Zimmer Group part no.	Version
10.08.09.00001	LWR50F-01-02-A	Digital I/O UR3,UR5,UR10,UR16,UR3E,UR5E,UR10E,UR16E
10.08.09.00002	LWR50F-07-01-A	Digital I/O HANWHA HCR3/5/12
10.08.09.00003	LWR50F-10-01-A	Digital I/O DOOSAN M, A and H series
10.08.09.00005	LWR50F-09-01-A	Digital I/O Fanuc CRX
10.08.09.00006	LWR50F-00-04-A	IO-Link, ISO TK 50
10.08.09.00007	LWR50F-00-05-A	IO-Link, with LED ring ISO TK 50
10.08.09.00010	LWR50F-01-03-A	RS485 + LED UR3,UR5,UR10,UR16,UR3E,UR5E,UR10E,UR16E

Schmalz offers a wide range of quick-change modules (RMQC) especially for connecting the product to the standard robot systems available on the market:

1. <https://www.schmalz.com>



2. Alternatively, search for “quick-change module RMQC” on the Schmalz homepage.

3.2 Included in Delivery with ECBPMi MATCH

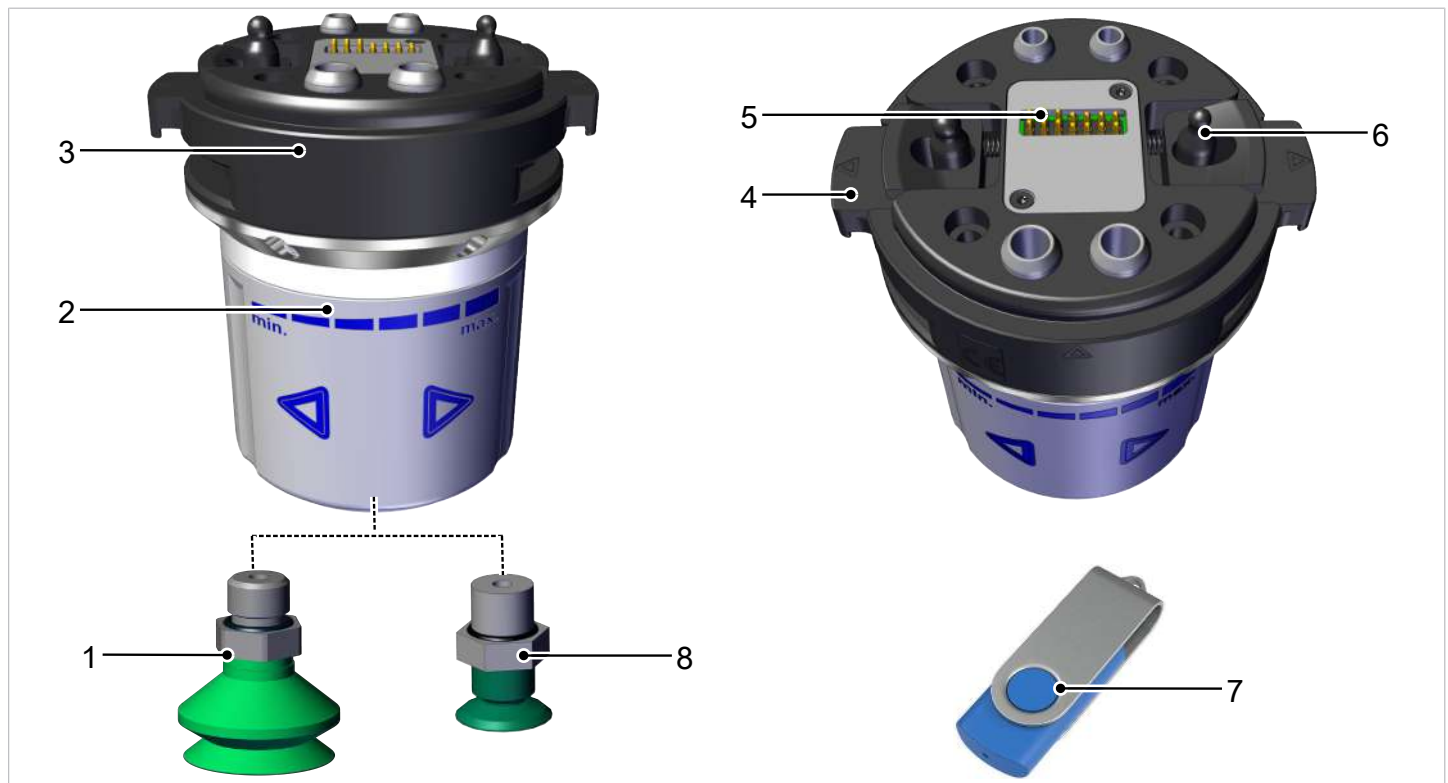

1	Bellows suction cup	2	ECBPMi MATCH
3	Quick-change system loose member	4	Locking mechanism
5	Electrical media transfer	6	Anti-rotation guard / torque absorption (poka-yoke)
7	USB stick	8	Flat suction cup

4 Storage Station (Accessories)

The storage station Accessories with part number 10.08.09.00013 is used to store the gripper with the loose member MATCH for automatic changeover to another gripper in the station.

The storage station can be used with or without sensors (for position and safety monitoring).

4.1 Function of the Sensors

The figure below shows an example of a combination consisting of a fixed member, loose member with gripper and storage station.

When the sensor system is used, it checks whether the loose member is present in the storage station.

The fixed member is then moved onto the loose member from above. The centering pins on the loose member help with insertion. Along with the fixed member and loose member, the robot moves to the "test position" sensor in the storage station.

The two sensors in the test position (test channel) respond when the locking mechanisms are lowered and are in contact with the fixed member.

When the fixed and loose members are joined together, the internal spring-pin contacts are connected for signal transmission.

As a result, the connect LED (3) changes color from red to green and a connect signal (depending on the variant) is transferred to the higher-level controller.

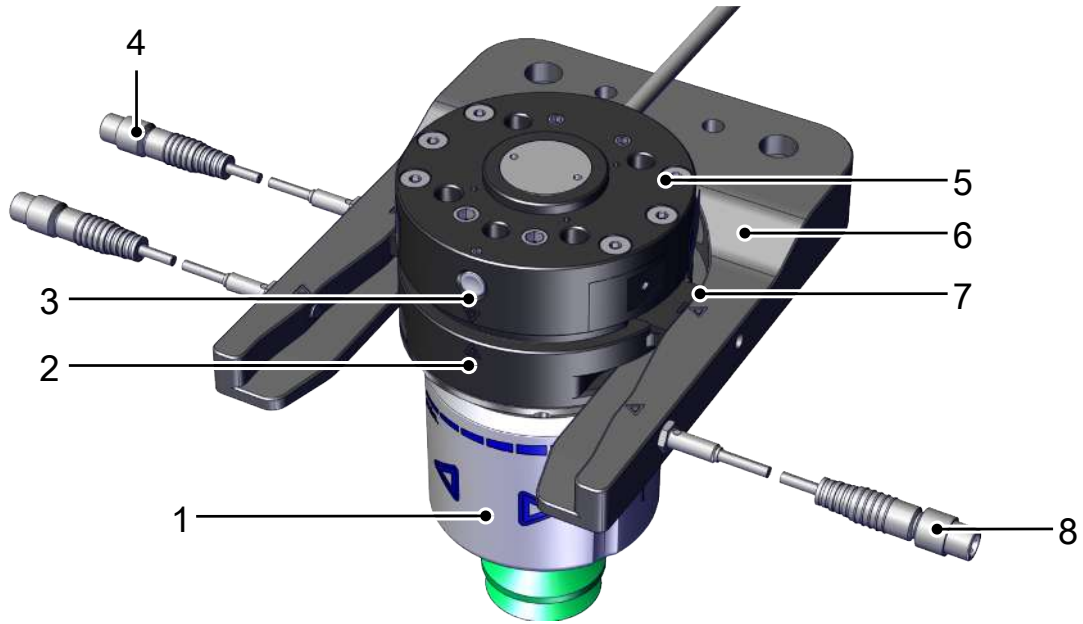

1	Gripper	5	Quick-change system RMQC MATCH fixed member
2	Quick-change system RMQC MATCH loose member	6	Storage station MATCH
3	Connect LED	7	Locking device
4	Storage position sensor (loose member present), optional	8	Sensor test position (locking mechanism lowered), 2x, optional

4.2 Circuit Diagram for Sensor System

Connection of the M8 3-Pin Sensor Connector:

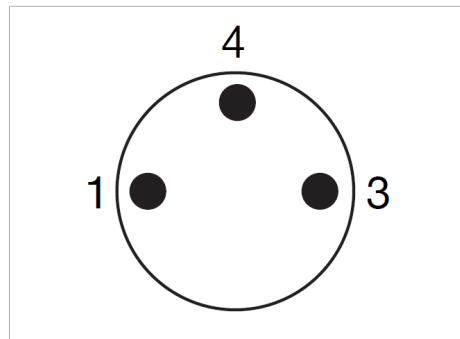

Circuit symbol for sensor in storage position

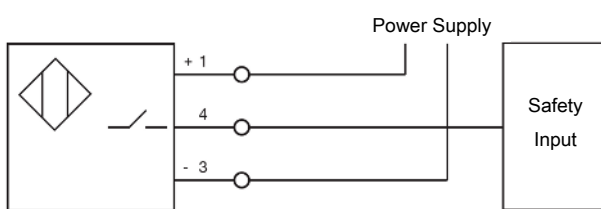

Series connection of two sensors in test position

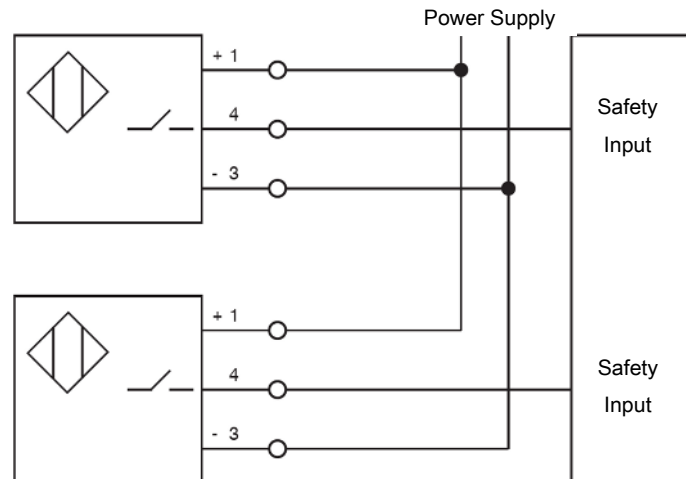

4.3 Configuration of “Test Position” Sensor

1. With the loose member connected to the fixed member, bring the markings on the locking elements into line with the front markings on the storage station.
2. Screw in the sensors (8) until they emit a signal.
3. Fasten the sensors (8) in this position.
4. Coat the sensors (8) with sealing wax (recommended).

4.4 Configuration of “Storage Position” Sensor

1. Place a loose member in the storage station.
2. Screw in the sensor (4) until it emits a signal.
3. Fasten the sensor (4) in this position.
4. Coat the sensor (4) with sealing wax (recommended).

5 Technical Data

5.1 General Parameters

Parameter	Symbol	Limit values		Comment
		min.	max.	
Temperatures of working medium and environment	T_{amb}	0° C	45 °C	—
Storage temperature	T_{sto}	-10 °C	60 °C	—
Humidity	H_{rel}	10% r.h.	90 % r.h.	Free from condensation
Degree of protection	—	—	IP40	—
Service life	—	6,000 h		At an ambient temperature of 25 °C
Dimensions	m	485 g		—

5.2 Tool-Changer-Specific Data

Electrical energy transmission	Integrated
Interlocking hub	1 mm
Repeatability in X, Y	0.05 mm
Repeatability in Z	0.05 mm
Tightening force	50 N
Releasing force	0 N
Max. axis offset during coupling in X, Y	1.0 mm

5.3 Static Load Limits

These specifications apply for static loads. The maximum load limits given here apply to the ECBPMi only. For use in combination with an HRC-capable robot, observe the maximum weight limits determined by the manufacturer of the robot.

¹ horizontal installation

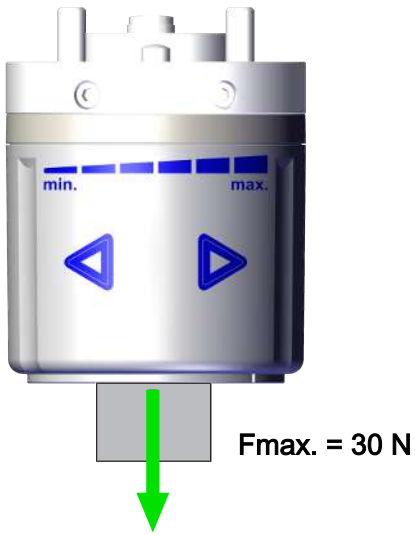

² vertical installation

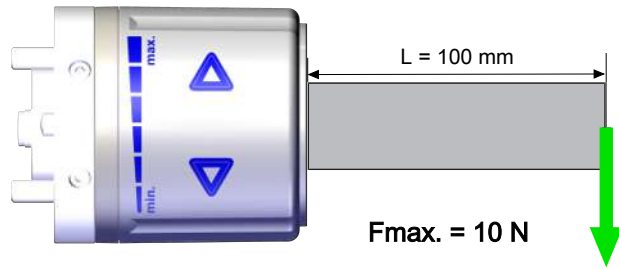

5.4 Dimensions

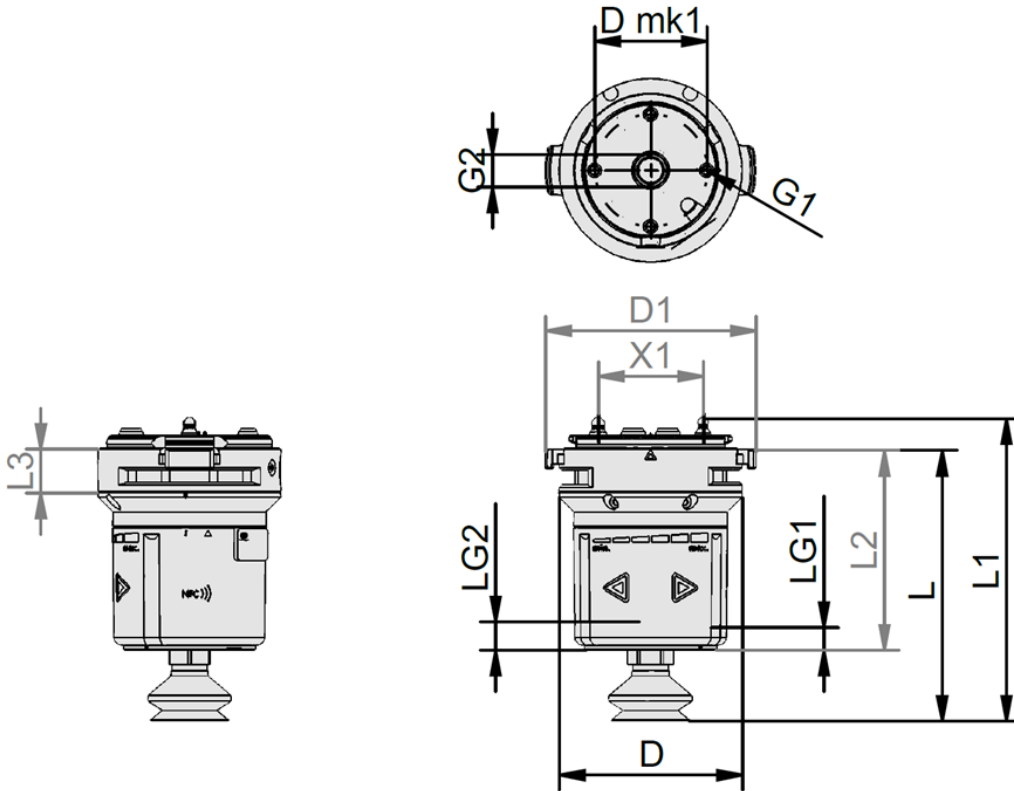

D	D1	L	L1	L2	L3	LG1	LG2	Dmk1	G1	G2	X1
75	86.5	82.4	95	81.9	18	6	11	46	M4 internal thread	1/4" internal thread	43

All dimensions given in millimeters [mm].

6 Transportation and Storage

6.1 Checking the Delivery

The scope of delivery can be found in the order confirmation. The weights and dimensions are listed in the delivery notes.

1. Compare the entire delivery with the supplied delivery notes to make sure nothing is missing.
2. Damage caused by defective packaging or occurring in transit must be reported immediately to the carrier and J. Schmalz GmbH.

6.2 Unpacking the Device

Remove product packaging only to the extent required for further internal transport.



NOTE

Improper unpacking

Improper handling results in product failure.

- ▶ Avoid dirt on and damage to the pin contacts.
- ▶ Do not touch the pin contacts without suitable ESD protection.

6.3 Transport / Storage / Preservation



NOTE

Dropping the product or subjecting it to impacts

Damage to the product and/or malfunctions

- ▶ Do not drop the product or subject it to impacts.

- The product must always be transported and stored in its original packaging.
- Make sure that no undesired movements can take place during transport if the product is already mounted on the higher-level machine unit.
- Before starting operations and after transport, check all energy, communication and mechanical connections.
- Follow the steps below when the product is stored over a longer period of time:
 - Keep the storage location dry and free from dust to the greatest extent possible.
 - Maintain the temperature range of 5° to 50° C and avoid temperature fluctuations.
 - Avoid wind, drafts and condensation.
 - Seal off the product from dust with a weather and tear-resistant film.
 - Avoid direct sunlight.
- Clean all components. All dirt must be removed from the components.
- Visually inspect all components.
- Remove foreign bodies.
- Close electrical connections using suitable covers.

7 Installation

7.1 Installation Instructions



⚠ WARNING

Risk of injury due to the unexpected movement of the plant or machine in which the product is to be installed.

Risk of injury

- ▶ Switch off the machine's power supply before performing any work.
- ▶ Secure the machine against unintentional activation.
- ▶ Check the machine for possible residual energy.



⚠ CAUTION

Improper installation or maintenance

Personal injury or damage to property

- ▶ Prior to installation and before maintenance work, the vacuum generator must be disconnected from the power supply and secured against unauthorized restart!



⚠ CAUTION

Risk of injury due to the unexpected movement of the product while connecting the power supply.

Risk of injury

- ▶ Switch off the product's power supply before performing any work.
- ▶ Secure the power supply against unintentional activation.
- ▶ Check the product for possible residual energy.

For safe installation, the following instructions must be observed:



⚠ WARNING

Since no pneumatic media duct is provided, if compressed air is applied to one of the compressed air connections, there may be an uncontrolled media leak below the loose member of the quick-change module.

Risk of injury from compressed air

- ▶ Operate the compressed air and vacuum connections on the quick-change module RMQC-U without media or seal with screw plugs or set screws.

- Use only the connectors, mounting holes and attachment materials that have been provided.
- Firmly connect and secure electrical cable connections to the vacuum generator.

7.2 Mounting of RMQC Fixed Member and RMQC Loose Member

Anti-rotation guard (poka-yoke connection):

The different sized bolts (1) on the RMQC loose member as well as a marking (2) on the RMQC loose member and on the RMQC fixed member ensure safe mounting.

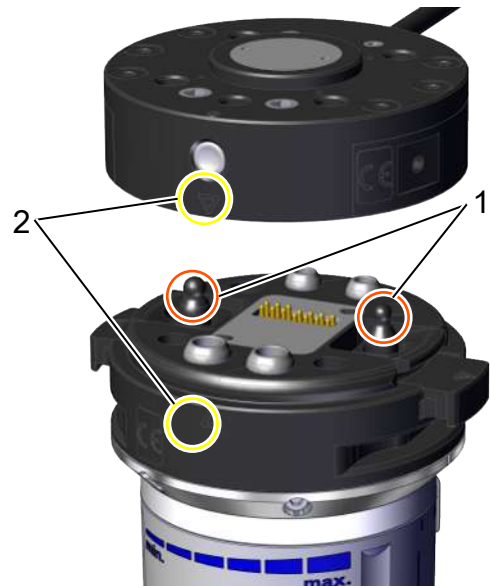

Manual gripper change:

- ▶ Manually actuate (press) the locking mechanism on both sides of the RMQC loose member. Connect the RMQC loose member with the RMQC fixed member. The two markings (triangles) must point to each other. Then release the locking mechanism.



⇒ The RMQC fixed and loose members are locked together.

Automatic gripper change:

In order to perform an automatic gripper change, the optionally available storage station is required.

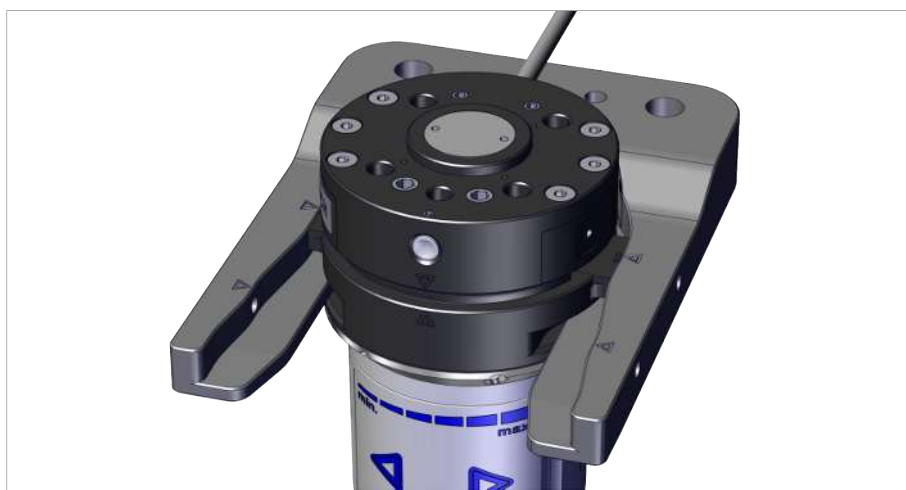

- ▶ The quick-change module RMQC fixed member (on the robot arm) is moved onto the RMQC loose member in the storage station and automatically locked when it moves out of the storage position.

The RMQC fixed member is also separated from the RMQC loose member in the storage station.

Corresponding recesses (grooves) are provided in the RMQC loose member, which engage with the fork arms of the storage station. Due to the different heights of the grooves and fork arms, the RMQC loose member can only be moved into the storage station from one side; failure to do so may damage the storage station.

7.3 Electrical Connection



⚠ WARNING

Electric shock

Risk of injury

- ▶ Operate the product using a power supply unit with protected extra-low voltage (PELV).

The product has an internal electrical connection. This means that the gripper or the RMQC loose member has integrated contacts. All signals are transmitted via these contacts.

The electrical contacts must always be dry, clean and undamaged. Damage to the contacts can cause the product to malfunction.

7.4 Static Electricity



NOTE

Static Electricity

Failure to comply may result in damage to property

- ▶ If ESD-sensitive parts come into contact with the product, you must ensure that the product is grounded.

- ▶ Connect the product via the mounting option for ESD dissipation (grounding).

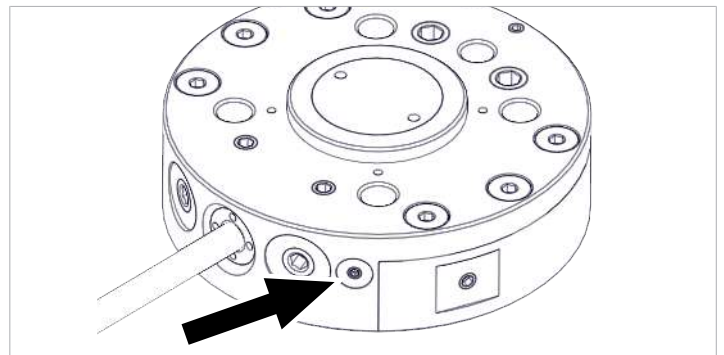

8 Operation

8.1 Preparations



⚠ WARNING

Extraction of hazardous media, liquids or bulk material

Personal injury or damage to property!

- ▶ Do not extract harmful media such as dust, oil mists, vapors, aerosols etc.
- ▶ Do not extract aggressive gases or media such as acids, acid fumes, bases, biocides, disinfectants or detergents.
- ▶ Do not extract liquids or bulk materials, e.g. granulates.

The following measures must be taken each time the product is activated:

- Check the product for visible damage. Correct any faults or report them to the supervising personnel.
- Ensure that only authorized persons are present in the working area of the machine or system in order to prevent any hazard from switching on the machine.
- Ensure that the danger zone of the machine or system is free of persons during automatic operation in non-HRC applications.

8.2 Hot-Plug Function

The product has a hot-plug function. A quick-change module loose member can therefore be changed (uncoupled from the quick-change module fixed member) when the supply voltage is applied.

9 Maintenance and Cleaning

9.1 Safety Instructions for Maintenance



⚠ WARNING

Risk of injury due to incorrect maintenance or troubleshooting

- ▶ Check the proper functioning of the product, especially the safety features, after every maintenance or troubleshooting operation.



⚠ CAUTION

Blowing off or cleaning the product with compressed air

Risk of injury and damage to the product

- ▶ Never blow off the product with compressed air.



⚠ CAUTION

Use of Cleaners Containing Solvents

Damage to the product (seals, insulation, coatings and other surfaces may be damaged by cleaners that contain solvents) and potentially damage to health

- ▶ Use a chemically and biologically neutral cleaning agent.
- ▶ Use cleaning agent that is rated as non-harmful to health.
- ▶ The use of the following cleaning agents is strictly prohibited:
 - Acetone
 - white spirit
 - cellulose thinner/turpentine oil (solvents)

9.2 Maintenance

The product must be checked regularly for possible corrosion, damage and contamination by means of a visual inspection.

We recommend commissioning Schmalz customer service to perform maintenance.

Unauthorized disassembly and assembly of the product can lead to complications, as special assembly devices are sometimes required.



Schmalz stipulates the following checks and check intervals. The operator must comply with the legal regulations and safety regulations applicable at the location of use. These intervals apply to single-shift operation. For heavier use, such as multi-shift operation, the intervals must be shortened accordingly.

Maintenance task	When starting work	Weekly	As required	Every six months
Visually inspecting the product and its surroundings	X			
Check electrical contacts/electrical connections/connection cables for damage and function		X		
Check the locking device		X		
Clean the product			X	
Maintain the locking device for and positioning of the loose member				X
The operating instructions are available, legible and can be accessed by personnel				X

The visual inspection covers only the components and their function. If you identify irregularities or damage during the visual inspection, you must carry out a more detailed check of the components.

10 Spare and Wearing Parts, Accessories

10.1 Spare and Wearing Parts

Part no.	Type	Description	Part type
10.03.01.00500	ECBPMi 24V-DC FK UNI	Mini-CobotPump ECBPMi	Spare part
10.03.01.00584	ECBPMi 24V-DC FK RS-485	Mini-CobotPump ECBPMi RS485	Spare part
10.01.06.04530	SPB1 30 ED-65 1/4" external thread	Bellows suction cup (round), 1/4" external thread	Wearing part
10.01.01.14621	SFF 20 SI-55 1/4" external thread	Flat suction cup (round), 1/4" external thread	Wearing part

The accessory parts listed here are current as of the writing of the Assembly instructions. An up-to-date overview of all accessory parts for the ECBPMi MATCH can be found at www.schmalz.de

10.2 Accessories

Part no.	Designation	Note
10.08.09.00001	Quick-change module RMQC MATCH fixed member	for UR
10.08.09.00002	Quick-change module RMQC MATCH fixed member	for HANWHA
10.08.09.00003	Quick-change module RMQC MATCH fixed member	for DOOSAN M-, A- and H-Series
10.08.09.00005	Quick-change module RMQC MATCH fixed member	for FANUC
10.08.09.00006	Quick-change module RMQC MATCH fixed member	IOL
10.08.09.00007	Quick-change module RMQC MATCH fixed member	IOL with LED ring
10.08.09.00010	Quick-change module RMQC MATCH fixed member	UR RS485
21.04.05.00080	Connection cable, ASK B-M12-5 5000 K-5P	—
10.08.09.00013	STATION MATCH	Storage station MATCH
21.01.09.00072	Inductive sensor (for storage station)	2 sensors can be mounted opposite each other for each position Pos. 1 = test position (front position) Pos. 2 = storage position (rear position)
10.08.09.00014	Smart Communication Module (SCM)	Only in combination with part 10.08.09.00006 or 10.08.09.00007

Part no.	Designation	Note
10.01.06.04530	Bellows suction cup (round) SPB1 30 ED-65 1/4" external thread	1/4" external thread
10.01.01.14621	Flat suction cup (round) SFF 20 SI-55 1/4" external thread	1/4" external thread

Additional accessories including a wide range of suction cups and the gripper SLG, can be found at www.schmalz.de.

11 Taking the Product Out of Operation and Disposal

If the product reaches the end of the utilization phase, it may be fully disassembled and disposed of. Only qualified specialist staff may prepare the product for disposal.

1. Fully disconnect the product from the power supply.
2. Dispose of the components properly based on their material groups.

For proper disposal, contact a company specializing in the disposal of technical goods and instruct the company to observe the applicable disposal and environmental regulations.

12 Declarations of Conformity

12.1 EU Declaration of Incorporation

The product specified is solely intended for installation indoors in a complete system. Startup is prohibited until the end product has been declared to comply with the Directive 2006/42/EC.

The manufacturer commits to provide special documentation of the partly completed machinery to national authorities in electronic form if requested. The special technical documentation belong to the machine as per Annex VII Part B has been created.

The manufacturer Schmalz confirms that the product described in this Assembly instructions with the designation "ECBPMi MATCH" fulfills the following applicable EU directive:

2006/42/EC	Machinery Directive
------------	---------------------

The following harmonized standards were applied:

EN ISO 12100	Safety of machinery — General principles for design — Risk assessment and risk reduction
EN 61000-6-2+AC	Electromagnetic compatibility (EMC) - Part 6-2: Generic standards - Immunity for industrial environments
EN 61000-6-3+A1+AC	Electromagnetic compatibility (EMC) - Part 6-3: Generic standards - Emission standard for residential, commercial and light-industrial environments
EN IEC 63000	Technical documentation for the assessment of electrical and electronic products with respect to the restriction of hazardous substances

Additional technical standards and specifications were applied:

EN ISO 9409-1	Manipulating industrial robots – Mechanical interfaces – Part 1: Plates
ISO TS 15066	Human-robot collaboration



The Declaration of Incorporation valid at the time of product delivery is delivered with product or made available online. The standards and directives cited here reflect the status at the time of publication of the operating and assembly instructions.

12.2 EC Conformity

EU Conformity Declaration

The manufacturer Schmalz confirms that the product described in this Assembly instructions with the designation "ECBPMi MATCH" fulfills the following applicable EU directives:

2014/30/EU	Electromagnetic Compatibility
2011/65/EU	RoHS Directive

The following harmonized standards were applied:

EN ISO 12100	Safety of machinery — General principles for design — Risk assessment and risk reduction
EN 61000-6-2+AC	Electromagnetic compatibility (EMC) - Part 6-2: Generic standards - Immunity for industrial environments
EN 61000-6-3+A1+AC	Electromagnetic compatibility (EMC) - Part 6-3: Generic standards - Emission standard for residential, commercial and light-industrial environments
EN IEC 63000	Technical documentation for the assessment of electrical and electronic products with respect to the restriction of hazardous substances

Additional technical standards and specifications were applied:

EN ISO 9409-1	Manipulating industrial robots – Mechanical interfaces – Part 1: Plates
ISO TS 15066	Human-robot collaboration



The EU Declaration of Conformity valid at the time of product delivery is delivered with product or made available online. The standards and directives cited here reflect the status at the time of publication of the operating and assembly instructions.

12.3 UKCA Declaration of Incorporation

The manufacturer Schmalz confirms that the product described in these operating instructions fulfills the following applicable UK regulations:

2008	Supply of Machinery (Safety) Regulations
------	--

The product specified is solely intended for installation indoors in a complete system. The start of operations shall be prohibited until the conformity of the final product with the "Supply of Machinery (Safety) Regulations 2008" has been established.

The manufacturer commits to provide special documentation of the partly completed machinery to national authorities in electronic form if requested. The special technical documentation belonging to the machine as per Annex VII Part B has been created.

The following designated standards were applied:

EN ISO 12100	Safety of machinery — General principles for design — Risk assessment and risk reduction
EN 61000-6-2+AC	Electromagnetic compatibility (EMC) - Part 6-2: Generic standards - Immunity for industrial environments
EN 61000-6-3+A1+AC	Electromagnetic compatibility (EMC) - Part 6-3: Generic standards - Emission standard for residential, commercial and light-industrial environments
EN IEC 63000	Technical documentation for the assessment of electrical and electronic products with respect to the restriction of hazardous substances

Additional technical standards and specifications were applied:

EN ISO 9409-1	Manipulating industrial robots – Mechanical interfaces – Part 1: Plates
ISO TS 15066	Human-robot collaboration



The Declaration of Incorporation (UKCA) valid at the time of product delivery is delivered with the product or made available online. The standards and directives cited here reflect the status at the time of publication of the operating and assembly instructions.

12.4 UKCA Conformity

The manufacturer Schmalz confirms that the product described in these operating instructions fulfills the following applicable UK regulations:

2016	Electromagnetic Compatibility Regulations
2012	The Restriction of the Use of Certain Hazardous Substances in Electrical and Electronic Equipment Regulations

The following designated standards were applied:

EN ISO 12100	Safety of machinery — General principles for design — Risk assessment and risk reduction
EN 61000-6-2+AC	Electromagnetic compatibility (EMC) - Part 6-2: Generic standards - Immunity for industrial environments
EN 61000-6-3+A1+AC	Electromagnetic compatibility (EMC) - Part 6-3: Generic standards - Emission standard for residential, commercial and light-industrial environments
EN IEC 63000	Technical documentation for the assessment of electrical and electronic products with respect to the restriction of hazardous substances

Additional technical standards and specifications were applied:

EN ISO 9409-1	Manipulating industrial robots – Mechanical interfaces – Part 1: Plates
ISO TS 15066	Human-robot collaboration



The Declaration of Conformity (UKCA) valid at the time of product delivery is delivered with the product or made available online. The standards and directives cited here reflect the status at the time of publication of the operating and assembly instructions.