



# Operating Instructions

## Controller OFG

**Note**

The Operating instructions were originally written in German. Store in a safe place for future reference. Subject to technical changes without notice. No responsibility is taken for printing or other types of errors.

**Published by**

© J. Schmalz GmbH, 12/22

This document is protected by copyright. J. Schmalz GmbH retains the rights established thereby. Reproduction of the contents, in full or in part, is only permitted within the limits of the legal provisions of copyright law. Any modifications to or abridgments of the document are prohibited without explicit written agreement from J. Schmalz GmbH.

**Contact**

J. Schmalz GmbH  
Johannes-Schmalz-Str. 1  
72293 Glatten, Germany  
T: +49 (0) 7443 2403-0  
schmalz@schmalz.de  
www.schmalz.com

Contact information for Schmalz companies and trade partners worldwide can be found at:  
[www.schmalz.com/salesnetwork](http://www.schmalz.com/salesnetwork)

# Contents

<b>1 Important Information</b>	5
1.1 Note on Using this Document	5
1.2 The technical documentation is part of the product	5
1.3 Type Plate	5
1.4 Symbols	6
<b>2 Fundamental Safety Instructions</b>	7
2.1 Intended Use	7
2.2 Non-Intended Use	7
2.3 Personnel Qualifications	7
2.4 Warnings in This Document	8
2.5 Residual Risks	8
2.6 Safety Features	9
2.7 Modifications to the Product	9
<b>3 Product Description</b>	10
3.1 Product Design	10
3.2 Description of the Control Panel	10
<b>4 Technical Data</b>	12
4.1 Technical Parameters	12
4.2 Dimensions	12
4.3 Finger Position vs. Control Level	13
4.4 Movement Path of the Gripper Fingers	13
<b>5 Transportation and Storage</b>	14
5.1 Checking the Delivery	14
5.2 Transport	14
<b>6 Installation</b>	15
6.1 Installation Instructions	15
6.2 Mechanical Attachment	15
6.3 Pneumatic connection	16
6.4 Electrical Connection	17
6.4.1 Establishing the Electrical Connection for the Controller OFG via the Connection Distributors	17
6.4.2 Assignment of Terminals and Positions of Various Electrical Connections	19
6.4.3 Use of the Different Ports	20
6.5 Installing the Software	21
6.6 Connecting the PC and Controller	21
<b>7 Operation</b>	25
7.1 Manual Activation	25
7.2 Controlling the Manual Settings Using the Signal Inputs	25
7.3 Direct Control via Signal Inputs	25
7.4 Control via Analog Input	25
7.5 Control via the USB Connection	25
7.6 Using the Software	26
7.7 Setting the Software	29

<b>8 Maintenance Plan and Cleaning</b> .....	33
<b>9 Warranty</b> .....	34
<b>10 Accessories</b> .....	35
<b>11 Taking the Product Out of Operation and Disposal</b> .....	36
<b>12 Declarations of Conformity</b> .....	37
12.1 EU Conformity.....	37
12.2 UKCA Conformity .....	37

# 1 Important Information

## 1.1 Note on Using this Document

J. Schmalz GmbH is generally referred to as Schmalz in this document.

The document contains important notes and information about the different operating phases of the product:

- Transport, storage, start of operations and decommissioning
- Safe operation, required maintenance, rectification of any faults

The document describes the product at the time of delivery by Schmalz and is aimed at:

- Installers who are trained in handling the product and can operate and install it
- Technically trained service personnel performing the maintenance work
- Technically trained persons who work on electrical equipment

## 1.2 The technical documentation is part of the product

1. For problem-free and safe operation, follow the instructions in the documents.
  2. Keep the technical documentation in close proximity to the product. The documentation must be accessible to personnel at all times.
  3. Pass on the technical documentation to subsequent users.
- ⇒ Failure to follow the instructions in these Operating instructions may result in life-threatening injuries!
- ⇒ Schmalz is not liable for damage or malfunctions that result from failure to heed these instructions.

If you still have questions after reading the technical documentation, contact Schmalz Service at:

[www.schmalz.com/services](http://www.schmalz.com/services)

## 1.3 Type Plate

The type plate (1) is attached to the packaging and contains the following data.

- Serial number
- Barcode
- Part number
- Name
- CE label

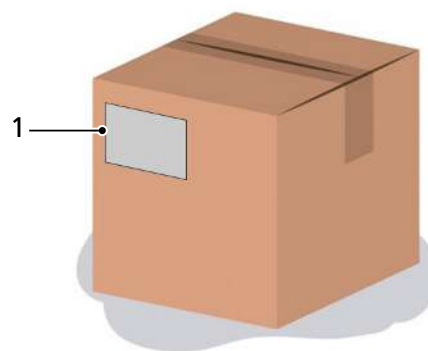

The type plate (2) is permanently attached to the product at the location shown and must always be clearly legible.

It contains important information about the product.

- CE label
- Part sales designation/type
- Part number

- Manufacturing date
- Serial number

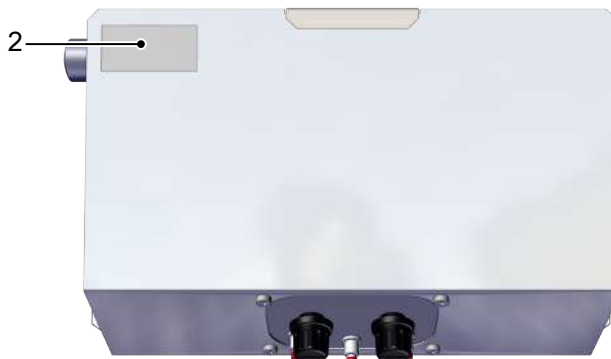

The Control and Combo variants also have the type plate (3) on the bottom of the housing.

- Barcode
- Part number
- Description
- Serial number
- Password
- Operating voltage
- Total weight

Please specify all the information above when ordering replacement parts, making warranty claims or for any other inquiries.

### 1.4 Symbols



This symbol indicates useful and important information.

- ✓ This symbol represents a prerequisite that must be met prior to an operational step.
- ▶ This symbol represents an action to be performed.
- ⇒ This symbol represents the result of an action.

Actions that consist of more than one step are numbered:

1. First action to be performed.
2. Second action to be performed.

## 2 Fundamental Safety Instructions

### 2.1 Intended Use

The controller STEU OFG is used to control and regulate the gripping movement of grippers in the OFG series.

The controller is used to control the "Close" and "Open" functions and movements of the gripper OFG by activating and deactivating the vacuum and compressed air.

The controller STEU OFG is an incomplete machine within the meaning of the Machinery Directive 2006/42/EC. The controller STEU OFG must be installed in a control cabinet or in appropriate housing. The controller STEU OFG must be operated only in combination with a robot or handling system.

The product is intended for industrial use.

Intended use includes observing the technical data and the installation and operating instructions in this manual.

### 2.2 Non-Intended Use

Schmalz does not accept any liability for any direct or indirect losses or damages that result from using the product. This applies, in particular, to any use of the product that is not in accordance with the intended purpose and to any use that is not described or mentioned in this documentation.

In particular, the following are considered non-intended use:

1. Use in potentially explosive atmospheres
2. Unauthorized refits

### 2.3 Personnel Qualifications

Unqualified personnel cannot recognize dangers and are therefore exposed to higher risks!

The operating company must ensure the following points:

- The personnel must be commissioned for the activities described in these instructions.
- The staff must be at least 18 years of age and physically and mentally capable.
- The product must be operated only by persons who have undergone appropriate training.
- Personnel must receive regular safety briefings (frequency as per country-specific regulations).

The following target groups are addressed in these instructions:

- Mechanical and electrical specialists who are responsible for installing, troubleshooting and maintaining the product.



The operator of the system must comply with country-specific regulations regarding the age, ability and training of the personnel.

Applicable for Germany:

A qualified employee is defined as an employee who has received technical training and has the knowledge and experience – including knowledge of applicable regulations – necessary to enable him or her to recognize possible dangers and implement the appropriate safety measures while performing tasks. Qualified employees must observe the relevant industry-specific rules and regulations.

## 2.4 Warnings in This Document

Warnings warn against hazards that may occur when handling the product. The signal word indicates the level of danger.

Signal word	Meaning
 <b>DANGER</b>	Indicates a high-risk hazard that will result in death or serious injury if not avoided.
 <b>WARNING</b>	Indicates a medium-risk hazard that could result in death or serious injury if not avoided.
 <b>CAUTION</b>	Indicates a low-risk hazard that could result in minor or moderate injury if not avoided.
<b>NOTE</b>	Indicates a danger that leads to property damage.

## 2.5 Residual Risks



### **DANGER**

#### **Electric shock from touching live components**

Serious injury or death!

- ▶ Make sure that the electrical components are not live before installation, maintenance and troubleshooting.

The device emits noise due to operation with compressed air and a vacuum.



### **CAUTION**

#### **Noise pollution caused by exhaust air or leakage during operation**

Hearing damage

- ▶ In the event of leakage, check connections and lines and remedy leakages
- ▶ Wear ear protectors.
- ▶ Only operate the integrated ejectors in the controller with a silencer.



### **CAUTION**

#### **Risk of a gripping finger bursting if the air pressure is too high when the gripping fingers are activated.**

Risk of injury

- ▶ Ensure that the pneumatic connection is operated with a maximum air pressure of 1.6 bar.
- ▶ Wear ear plugs and protective glasses.



### **CAUTION**

#### **Falling product**

Risk of injury

- ▶ Fasten or store the product securely at the location of use.
- ▶ Wear protective work shoes (S1).



**⚠ CAUTION****Compressed air or vacuum in direct contact with the eye**

Severe eye injury

- ▶ Wear eye protection
- ▶ Do not look into compressed air openings
- ▶ Do not look into the silencer air stream
- ▶ Do not look into vacuum openings, e.g. suction cups

**⚠ CAUTION****Depending on the purity of the ambient air, the exhaust air can contain particles, which escape from the exhaust air outlet at high speed.**

Eye injuries!

- ▶ Do not look into the exhaust air flow.
- ▶ Wear eye protection.

## 2.6 Safety Features

The controller STEU OFG must be connected to the safety technology for the robot to ensure work can be performed safely. The controller switches off the system if the necessary functions are unavailable.

## 2.7 Modifications to the Product

Schmalz assumes no liability for consequences of modifications over which it has no control:

1. The product must be operated only in its original condition as delivered.
2. Use only original spare parts from Schmalz.
3. The product must be operated only in perfect condition.

### 3 Product Description

#### 3.1 Product Design

The figure here shows an example of the Control version.

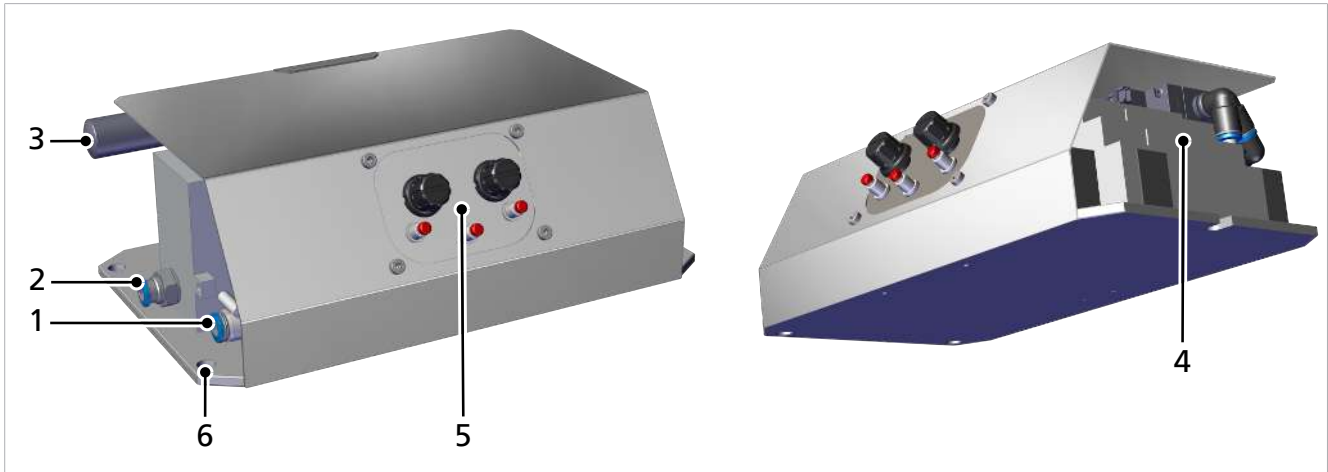

1	Compressed air connection	2	Pneumatic connection for gripper
3	Silencer	4	PLC electrical connector
5	Control panel	6	3x mounting holes

#### 3.2 Description of the Control Panel

For the "Control" version, the operator panel allows you to operate an OFG finger gripper manually.

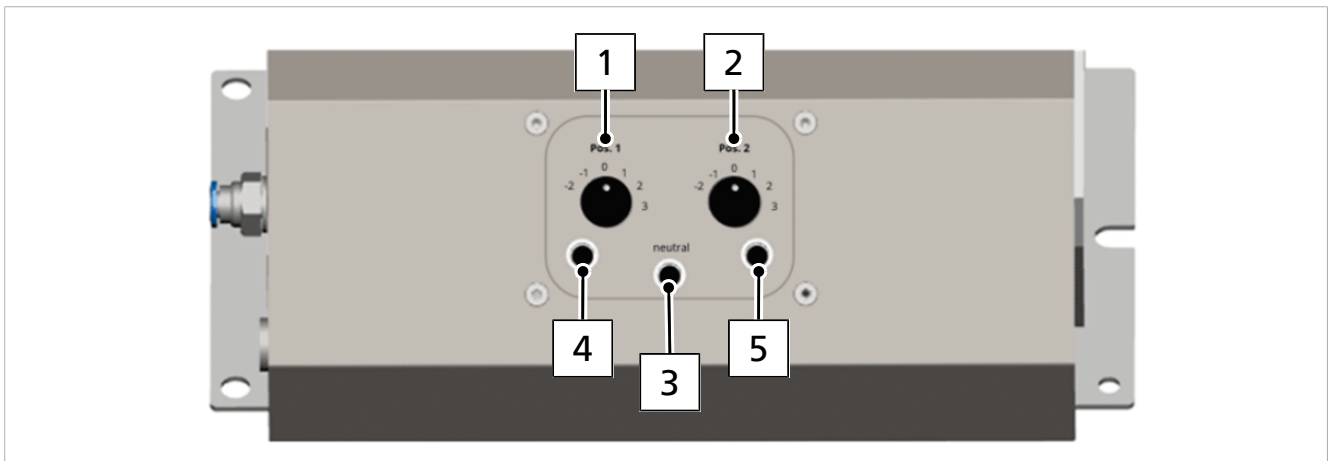

1	ROTARY SWITCH POS. 1	2	ROTARY SWITCH POS. 2
3	"NEUTRAL" BUTTON	4	POS. BUTTON 1
5	POS. BUTTON 2	—	—

## Manual Activation

You can use the two rotary switches (1) and (2) to select various preset profiles for closing and opening. In this case, the rotary switches have the same function/choose the same profiles:

- The profiles in the negative range open the finger gripper (opening angle through the vacuum value).
- Profile 0 is the neutral position.
- The profiles in the positive range close the finger gripper (gripping force through the pressure).

The power can be programmed for each profile.



Schmalz recommends using the right rotary switch (item 2) for the opening process (levels -2 to 0) and the left rotary switch (item 1) for the closing process (levels 1 to 3).

The reason here is to provide the same use as with the control method "Controlling the Manual Settings Using the Signal Inputs" (see chapter 7.2).

With the "Digital input" control method, item 1 (the left rotary switch) is assigned to the closing process and connection (A3), and item 2 (the right rotary switch) is assigned to the opening process and connection (A4).

The three buttons are used to execute the set levels:

**Button 4 (left):** Activates gripping by the finger gripper with the level between 1 and 3 that is selected on the rotary switch (item 1).

**Button 5 (right):** Activates the opening of the finger gripper with the level between -2 and 0 that is selected on the rotary switch (item 2).

**Button 3 (center):** Activates the neutralization of the finger gripper, where the system pressure and the position of the finger gripper are returned to the home position (50%).

## 4 Technical Data

### 4.1 Technical Parameters

Parameter	Basic	Control	Combo
Electrical supply [V]		24±	
Current [A]		1	
Pneumatic connection [bar]		6 – 8	
Operating temperature [°C]		0 – 50	
Operating medium	Compressed air, oiled or unoled in accordance with ISO 8573-1:2001, class 7-4-4		
Pneumatic connection		VSL 8-6	
Finger gripper connection		VSL 8-6	
Suction cup connection for Combo	—	—	VSL 8-6
Sound pressure level [dB(A)]	85		70
Controller	Normally open (NO) => vacuum on = fingers open (with the Combo, suction is also ON on the suction cup)		
Mass [kg]	1.7	2.5	2.6

### 4.2 Dimensions

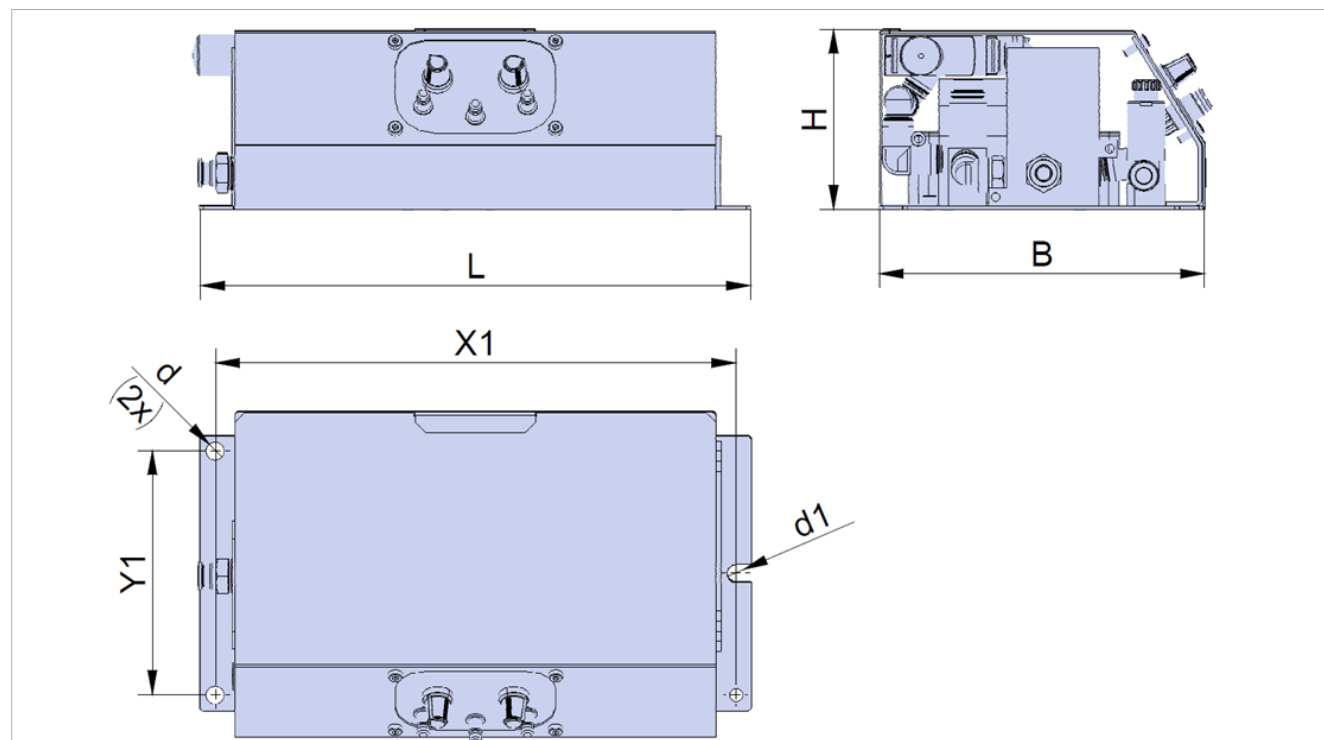

Part no.	H	L	B	X1	Y1	d	d1
10.01.51.00005	67	275	162.5	260	122	9	9
10.01.51.00006 and 10.01.51.00011	90						

All specifications are in mm.

### 4.3 Finger Position vs. Control Level

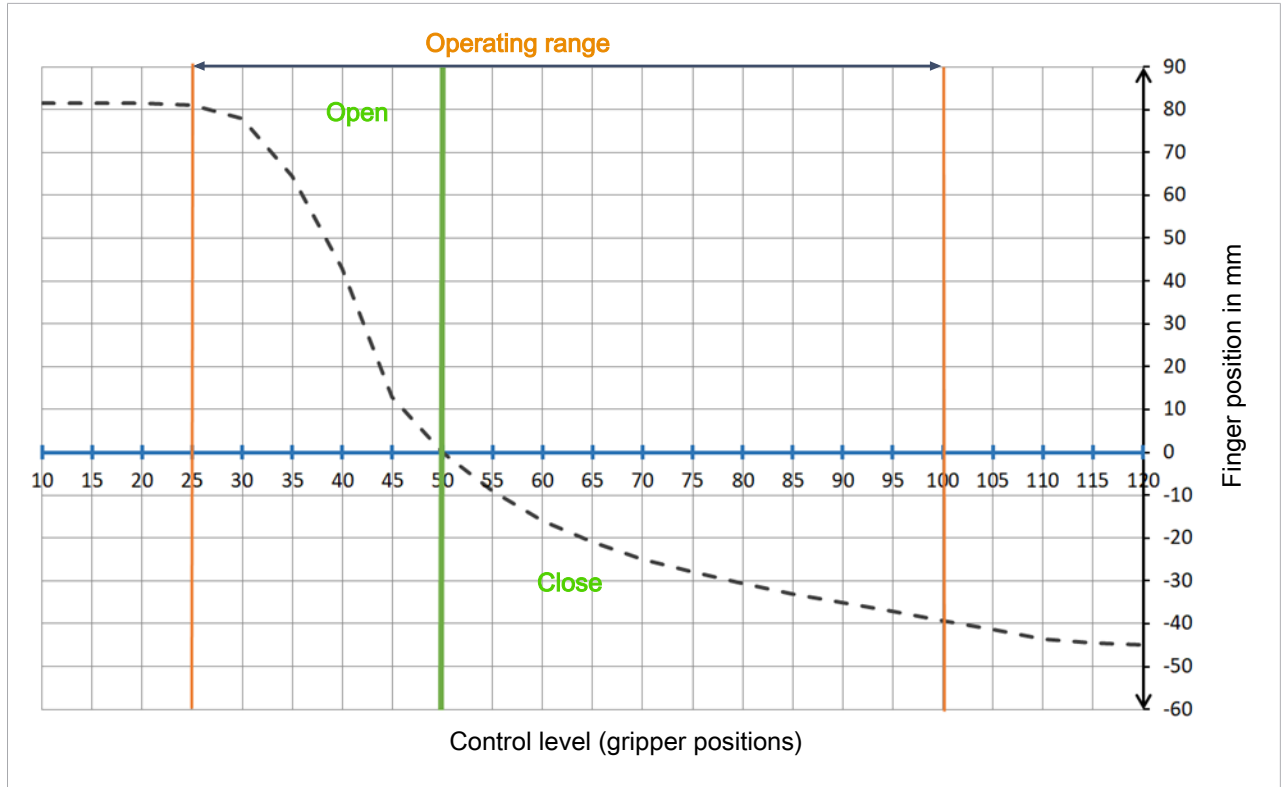

The curve shown here corresponds to an idealized course. The actual curves of the respective applications may deviate from this.

### 4.4 Movement Path of the Gripper Fingers

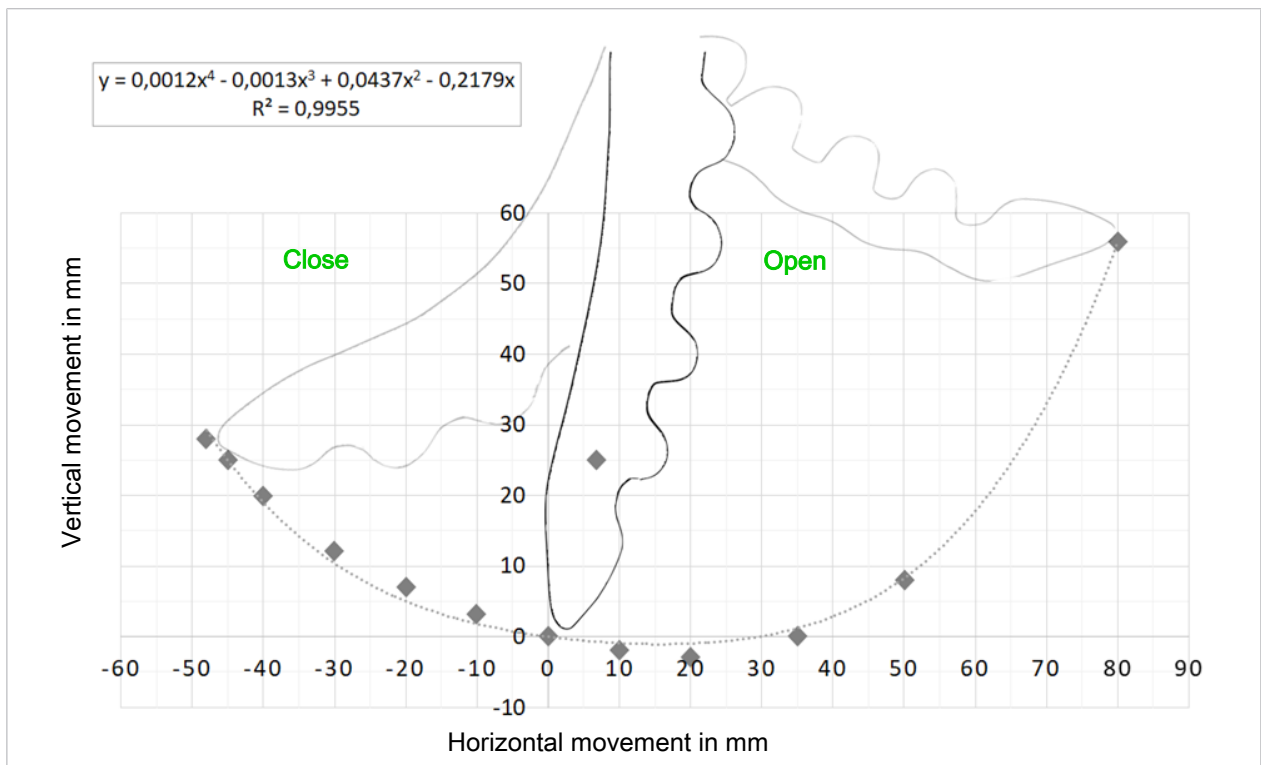

The curve shown here corresponds to an idealized course. The actual curves of the respective applications may deviate from this.

## 5 Transportation and Storage

### 5.1 Checking the Delivery

The scope of delivery can be found in the order confirmation. The weights and dimensions are listed in the delivery notes.

1. Compare the entire delivery with the supplied delivery notes to make sure nothing is missing.
2. Damage caused by defective packaging or occurring in transit must be reported immediately to the carrier and J. Schmalz GmbH.

### 5.2 Transport

Flawless and dust-free containers must be used for transport to and from the installation site, and professional safety measures must be ensured.

Only means of transport that comply with the statutory provisions and the specified loads must be used.

## 6 Installation

### 6.1 Installation Instructions



#### **CAUTION**

##### **Improper installation or maintenance**

Personal injury or damage to property

- ▶ Prior to installation and before maintenance work, the product must be disconnected from the power supply, depressurized (vented to the atmosphere) and secured against unauthorized restart.

For safe installation, the following instructions must be observed:

1. Use only the connections, mounting holes and attachment materials that have been provided.
2. Carry out mounting and removal only when the device is in an idle, depressurized state.
3. Pneumatic and electrical line connections must be securely connected and attached to the Controller OFG.

### 6.2 Mechanical Attachment

The controller OFG must be installed in a control cabinet or in appropriate housing.

- ▶ Fasten the controller OFG via the boreholes in the housing.

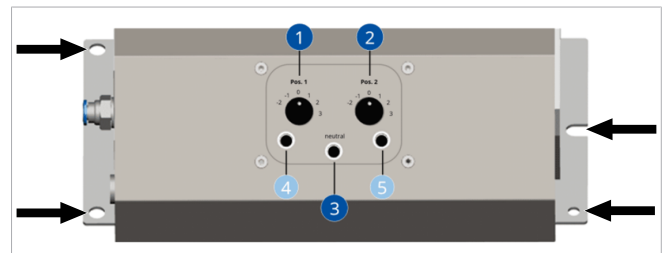

## 6.3 Pneumatic connection

### Basic and Control Versions

- ✓ The appropriate hose is ready for use:  
OD = 8 mm, ID = 6 mm
- 1. Fasten the pneumatic hose for the compressed air supply to the connection (1) (see the marking on the device).
- 2. Attach the pneumatic hose from the finger gripper to the connection (2) (see the marking on the device).

Basic

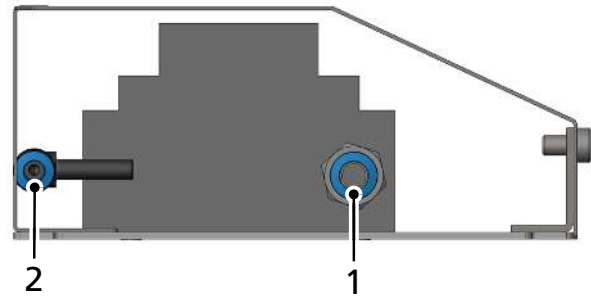

Control

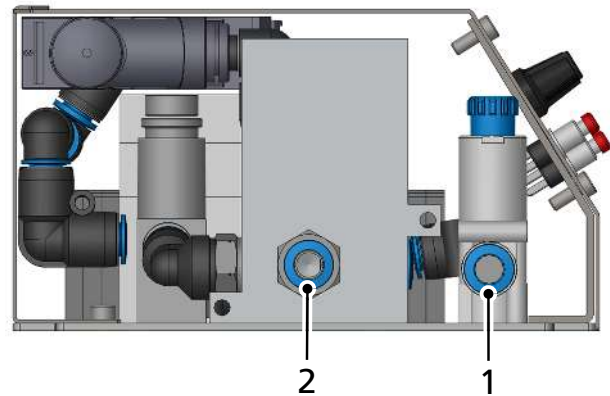

### Combo Version

- ✓ The appropriate hoses are ready for use:  
For the compressed air connection and the connection for the finger gripper, OD = 8 mm, ID = 6 mm  
For the vacuum connection for the suction cup, OD = 8 mm, ID = 6 mm
- 1. Connect the pneumatic hose for the compressed air supply to the connection (1) (note the marking on the device).
- 2. Connect the pneumatic hose for the finger gripper to the connection (2) (note the marking on the device).
- 3. Connect the pneumatic hose for the suction cup to the connection (3) (note the marking on the device).

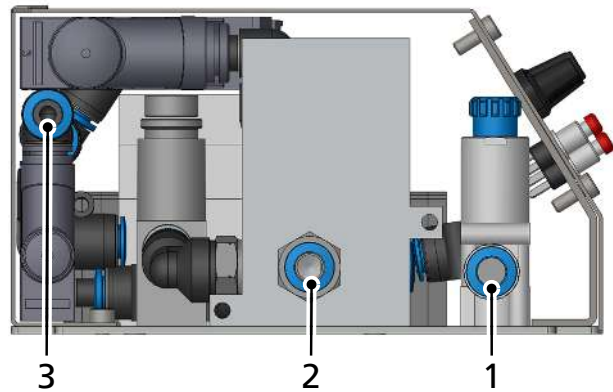



## 6.4 Electrical Connection



### NOTE

#### Incorrect power supply

Destruction of the integrated electronics

- ▶ Operate the product using a power supply unit with protected extra-low voltage (PELV).
- ▶ The system must incorporate safe electrical cut-off of the power supply in compliance with EN60204.
- ▶ Do not connect or disconnect the connector under tension and/or when voltage is applied.

### 6.4.1 Establishing the Electrical Connection for the Controller OFG via the Connection Distributors

To establish the electrical connection for the respective controller, first remove the cover.

1. Remove the cover for the Basic version. Unscrew and remove the two screws shown in the figure.

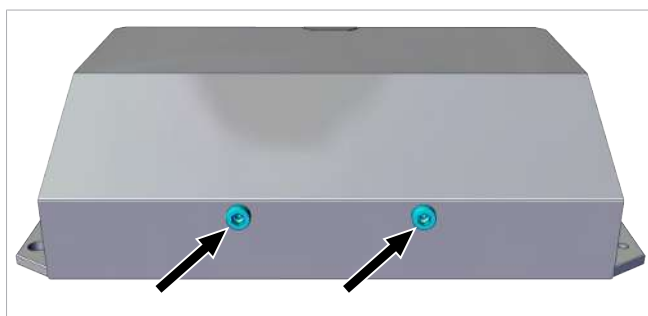

2. Carefully remove the cover.

1. Remove the cover from the Control or Combo version. Unscrew and remove the four screws shown in the figure.

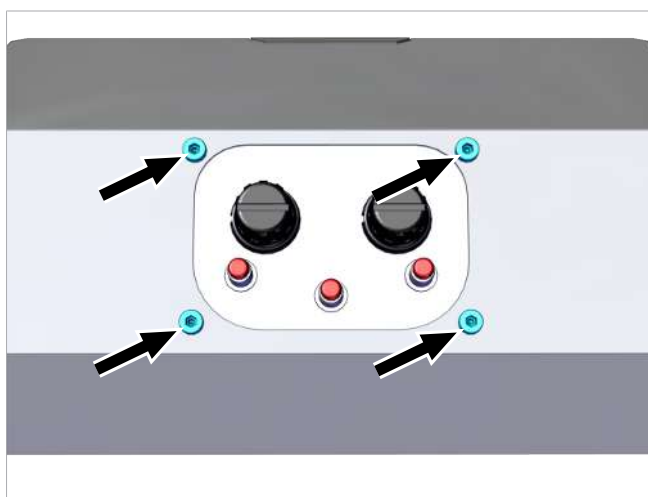

2. Carefully remove the cover.

## Basic Version

- ▶ Connect a suitable connection cable with open cable ends to the controller (1) using connection terminals 01 to 04:
  - Terminal 01: +24 V DC
  - Terminal 02: Ground
  - Terminal 03 pin "A1": +24 V for closing = compressed air active<sup>1)</sup>
  - Terminal 04 pin "A1": +24 V for opening = vacuum active<sup>1)</sup>

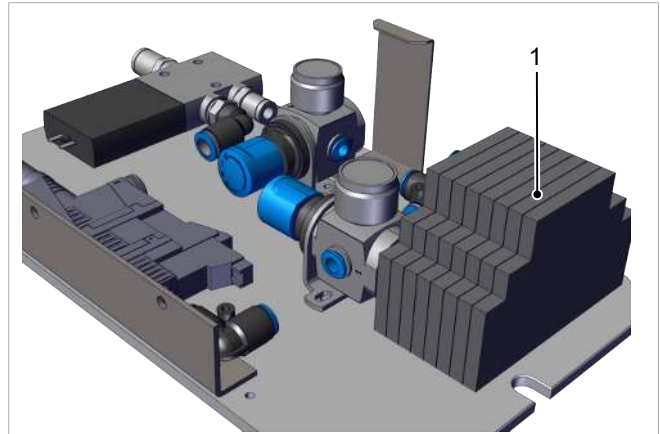

<sup>1)</sup> The signal should be present until the next change.

The Control and Combo control units have different connections:

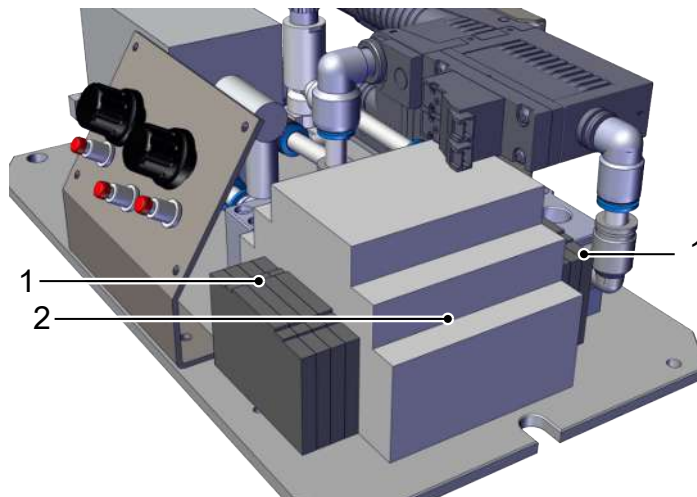

### Control Version

1. On the PLC (2):
  - Gripper profiles<sup>1)</sup>
  - Neutral position
  - USB and serial 5 V TTL UART connection (8N1, 115,200 bauds)
2. On the terminals (1) to the right and left of the PLC:
  - + 24 V DC and ground
  - DI for gripping and releasing
  - Analog input (0 to 10 V)
  - feedback, pressure reached

<sup>1)</sup> The profiles can be changed only using the software or a terminal program.

### Combo Version

1. On the PLC (2):
  - Gripper profiles<sup>1)</sup>
  - Neutral position
  - USB and serial 5 V TTL UART connection (8N1, 115,200 bauds)
  - Suction cup on/blow-off<sup>2)</sup>
2. On the terminals (1) near the PLC:
  - + 24 V DC and ground
  - DI for gripping and releasing
  - Analog input (0 to 10 V)
  - feedback, pressure reached

<sup>1)</sup> The profiles can be changed only using the software or a terminal program.

<sup>2)</sup> Only in combination with part number 10.01.51.00009 OFG... SPB4-30 for controlling the suction cup.

## 6.4.2 Assignment of Terminals and Positions of Various Electrical Connections

The following figure shows the control connections. The specifications in the table below shows the functions of the terminals and plugs.

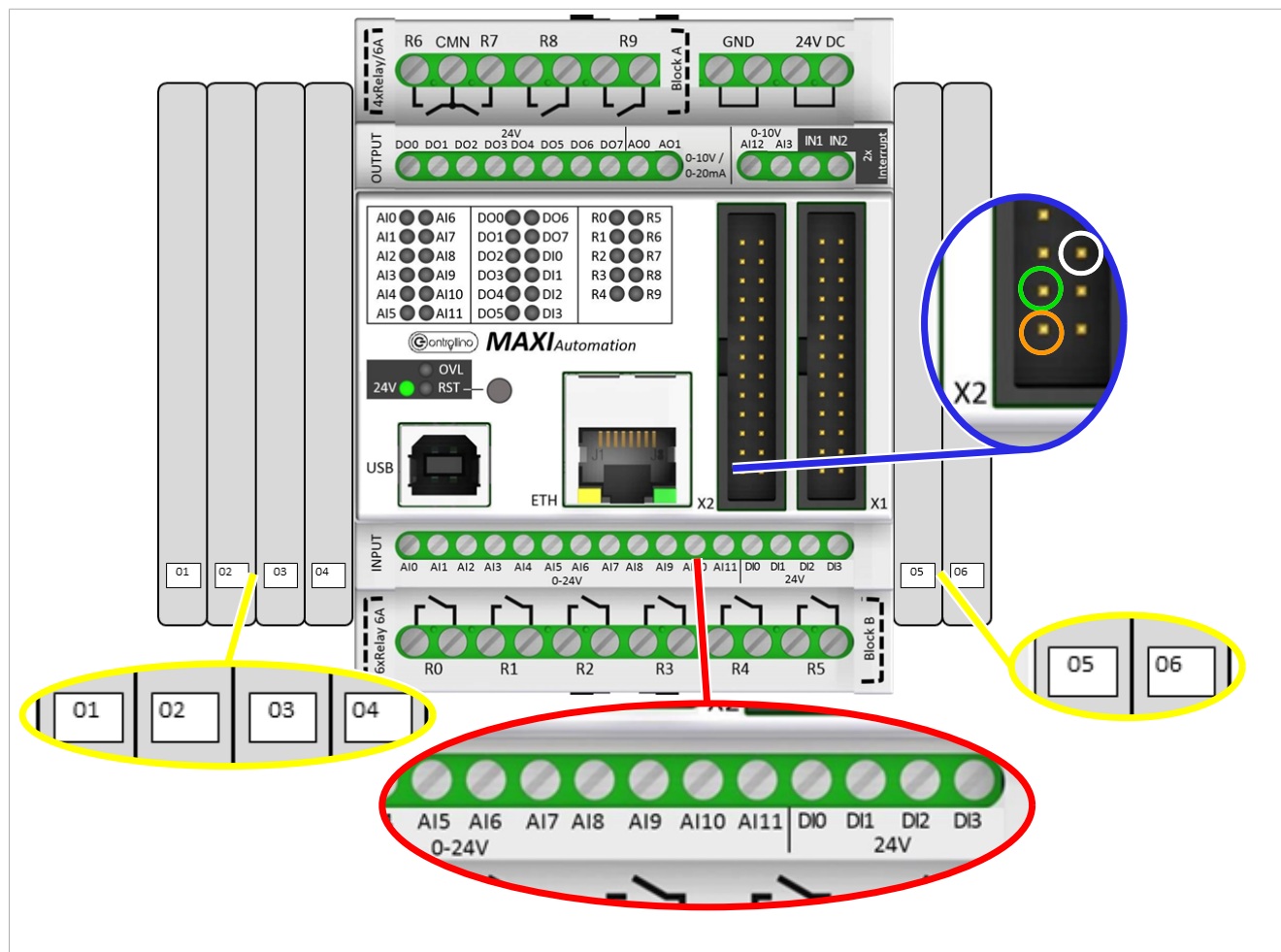

Area	PLC terminal no.	Description	Area	PLC terminal no.	Description
Yellow marking	01	24 V	Red marking	AI8	Go to gripper pos. 3 <sup>1)</sup>
	02	Mass		AI9	Go to gripper pos. 4 <sup>1)</sup>
	03	Pressure "on" = close finger		AI10	Go to gripper pos. 5 <sup>1)</sup>
	04	Vacuum "on" = open finger		AI11	Go to gripper pos. 6 <sup>1)</sup>
	05	Analog In (0 to 10 V)		DI0	Neutral position
	06	Feedback		DI2	Suction cup on (24 V = on; 0 V = off) <sup>2)</sup>
Red marking	AI6	Go to gripper pos. 1 <sup>1)</sup>	DI3	Blow-off off (24 V = on; 0 V = off) <sup>2)</sup>	
	AI7	Go to gripper pos. 2 <sup>1)</sup>	Blue marking	X2	5 V TTL UART serial connection (8N1, 115,200 bauds)

<sup>1)</sup> These can be changed only using the software or a terminal program

<sup>2)</sup> Only in combination with 10.01.51.00009 OFG... SPB4-30 for controlling the included suction cup cycle

## 6.4.3 Use of the Different Ports

PLC terminal number	Connection	Type	Application
01	Open cable end		24 V
02			Mass
03		DI	24 V = close gripper The gripper closes according to the gripper position selected manually on the control panel (position -2 to 3). Default setting: -1 (close 38.5 mm) <sup>2)</sup>
04		DI	24 V = open gripper The gripper opens according to the gripper position selected manually on the control panel (position -2 to 3). Default setting: 1 (25 mm open) <sup>2)</sup>
05		AI	0 to 10 V analog input The gripper is infinitely variable for opening/closing
06		DO	Feedback from the valve 24 V = pressure reached 0 V = pressure changed/movement to new position
AI6		DI	24 V = the gripper position goes to "-2" (can be selected in increments of 1 between 25 and 50) <sup>3)</sup> Default setting: 40 (43 mm open) <sup>2)</sup>
AI7			24 V = the gripper position goes to "-1" (can be selected in increments of 1 between 25 and 50) <sup>3)</sup> Default setting: 43 (38.5 mm open) <sup>2)</sup>
AI8			24 V = the gripper position goes to "0" (fixed gripper position in neutral position) <sup>3)</sup> Default setting: 50 (neutral position) <sup>2)</sup>
AI9			24 V = the gripper position goes to "1" (can be selected in increments of 1 between 50 and 100) <sup>3)</sup> Default setting: 80 (38.5 mm closed) <sup>2)</sup>
AI10			24 V = the gripper position goes to "2" (can be selected in increments of 1 between 50 and 100) <sup>3)</sup> Default setting: 90 (42 mm closed) <sup>2)</sup>
AI11			24 V = the gripper position goes to "3" (can be selected in increments of 1 between 50 and 100) <sup>3)</sup> Default setting: 100 (45 mm closed) <sup>2)</sup>
DI0			24 V = neutral position
DI2 <sup>1)</sup>	24 V = vacuum suction cup active		
DI3 <sup>1)</sup>	24 V = blow-off active		
USB interface	USB-B		USB

<sup>1)</sup> Only 10.01.51.00011 controller for OFG...SPB4-30. The signal should be maintained until the next change.

<sup>2)</sup> Position of the diagrams in chapters 4.3 and 4.4

<sup>3)</sup> The designation of the gripper positions depends on the designation within the software and the control panel on the control unit

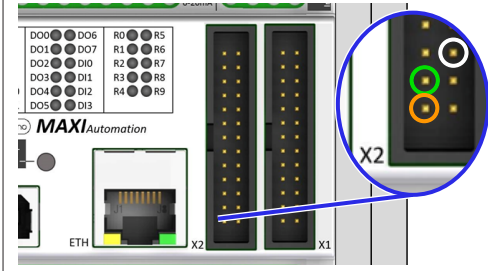
X2 interface		Type UART	Application Serial 5 V TTL UART connection (8N1, 115,200 bauds)
			Orange: GND Green: RX White: TX

## 6.5 Installing the Software

- ✓ Basic requirements for using the software: Windows 7/10 64-bit and Java Runtime Environment > 1.8.0.
1. Connect the stick to the PC.
  2. Extract the zip file on your local drive.
  3. Install the driver **dpinst-amd64.exe** to use the control element via USB.
  4. Select the suitable driver for your system.
    - ⇒ If you have Java Runtime Version > 1.8.0, select the following file: **Gripper\_1\_0\_1\_25** (size: approx. 5 MB (6 MB extracted))
    - ⇒ If you do not have Java Runtime Version > 1.8.0, select the file: **OFG\_Gripper\_1\_0\_1\_25\_bundled** (size: approx. 80 MB (190 MB extracted))
  5. Start the file "**Gripper\_1\_0\_1\_25.exe**" (note: The numbers of the last two digits may be higher due to changes).

## 6.6 Connecting the PC and Controller

1. Before starting the software, connect the OFG controller to your computer using a USB cable (see accessories).
2. Windows automatically assigns a specific COM port to the controller used. To connect the controller to the software, you must know the correct COM port.

3. How do you know the COM port is the correct one?  
 Click "Windows" and search for **1** and open **2** Microsoft Windows Device Manager.

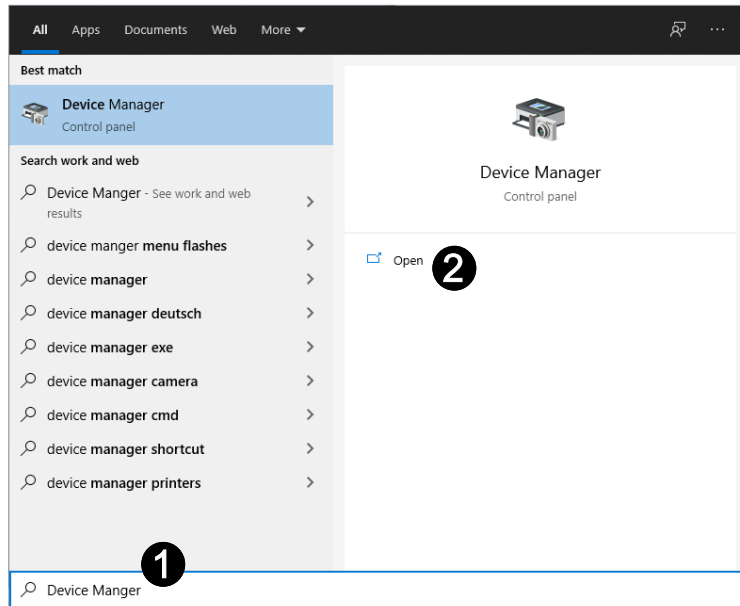

4. Windows Device Manager displays all the currently assigned devices.  
 In the "Ports" section, search for "Arduino Mega". In the parentheses, you can see the COM port windows assigned to your controller (here: COM 5).  
 The name "Arduino Mega" is displayed only if the driver **dpinst-amd64.exe** is installed.  
 If it is not installed, "Serial USB connection (COMx)" connection is displayed, for example

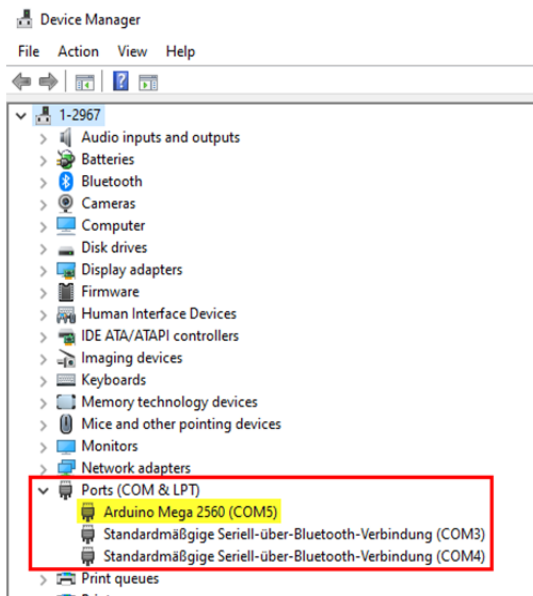

5. You can now run the .exe file.  
 > You can see the operating screen, which is divided into various sections:  
 a) GRIPPER POSITIONS:  
 b) TEST RANGE %  
 c) SET AIR HOSE LENGTH [m]

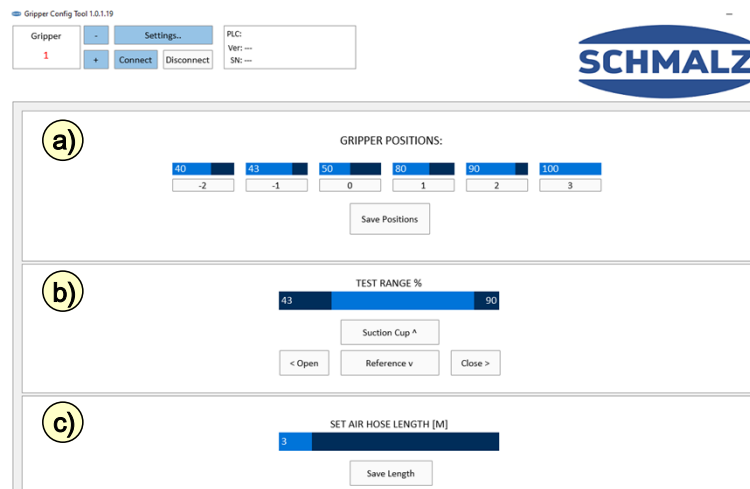

6. To connect the controller to the software, go to "Settings" to select the assigned COM port.

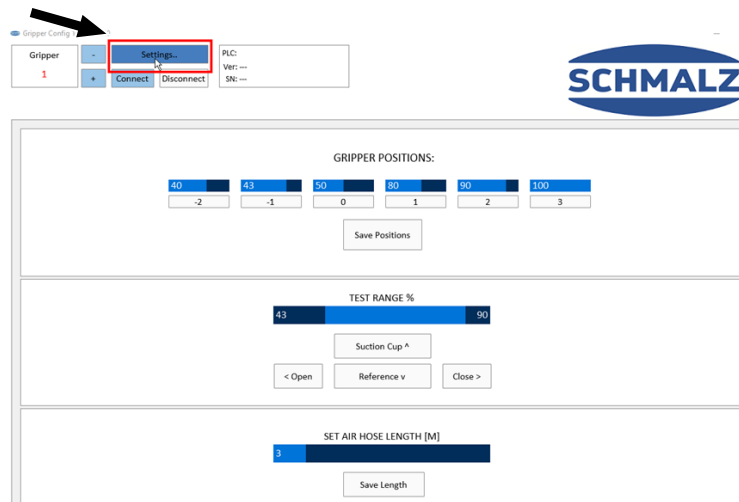

7. Click "Port scan" to scan all the COM ports that are currently assigned by Windows.

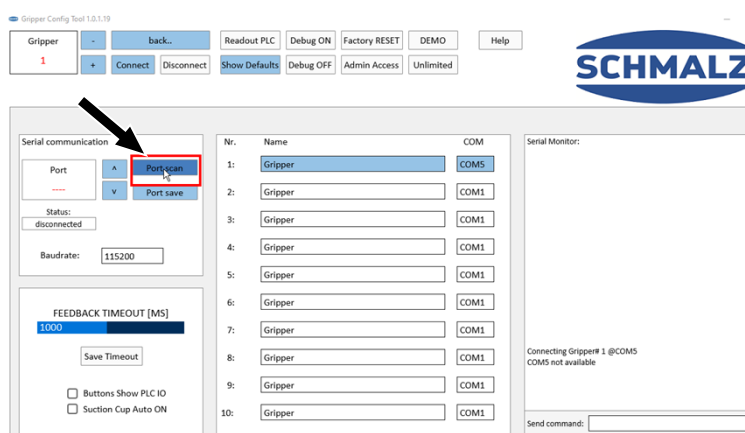

**8.** Windows displays all the assigned COM ports. You can view them by clicking “^” and “v” (this list is the same as the list you see in the Device Manager).

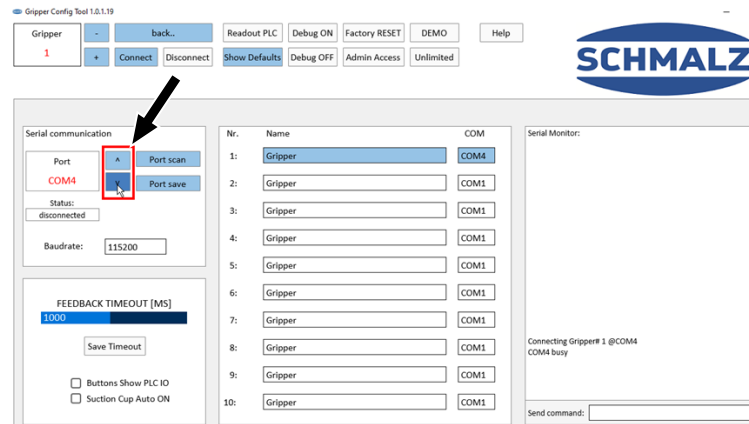

**9.** Please go to the Windows COM port assigned to your (here: COM5) controller (if necessary, click “^” or “v”), save it ① and connect it ②.

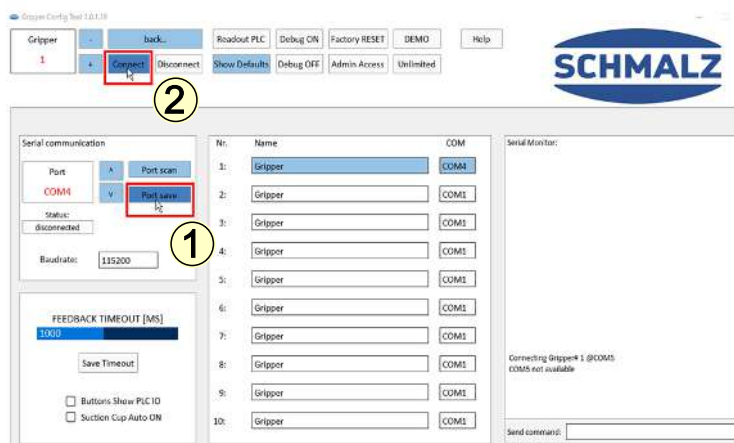

**10.** Display for the connection: The serial monitor displays a series of commands that end with “logged on”. In addition, a blue dot is displayed in the top right corner.

The software can be used (see the chapter “Operation” for information about using it).

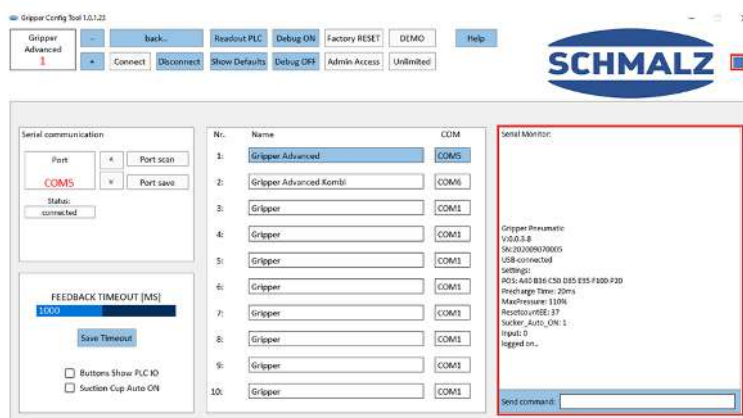



## 7 Operation

### 7.1 Manual Activation

You can use rotary switches (1) and (2) to preselect two gripper positions that are performed using the three buttons.

**Button (4):** Activates gripping by the finger gripper with the level between 1 and 3 that is selected on the rotary switch (item 1).

**Button (3):** Activates the neutralization of the finger gripper, where the system pressure and the position of the finger gripper are returned to the home position (50%).

**Button (5):** Activates the opening of the finger gripper with the level between -2 and 0 that is selected on the rotary switch (item 2).

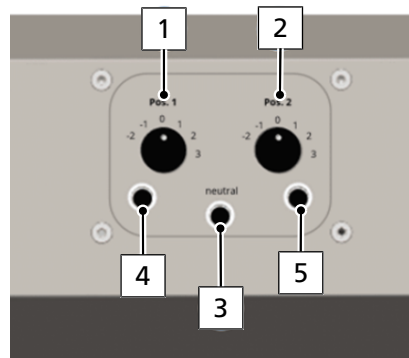

### 7.2 Controlling the Manual Settings Using the Signal Inputs

Instead of using the buttons, you can also control the manually preselected positions via a 24 V signal at inputs 03 or 04, as well as DI0 (neutralize). The signal should be present for at least 100 ms. Neutralization is always performed during activation.

### 7.3 Direct Control via Signal Inputs

Direct control of pins AI6 to AI11 means that preprogrammed positions can also be performed directly via 24 V signal 6. The signal should be applied for at least 100 ms before falling off again.

Use pin DI0 to perform neutralization again.

The software allows you to configure the 6 gripper positions via the USB interface.

### 7.4 Control via Analog Input

You can use an analog voltage between 0 and 10 V on pin 05 to perform 75 possible gripper positions and also neutralization.

When set to analog, the following voltage ranges that must not exceed 10 V apply:

- 0.0 – 0.5 V: Dead zone
- 0.5 – 9.0 V: Gripper positions 25 – 100%
- 9.0 – 9.5 V: Dead zone
- 9.5 – 10 V: Neutralize gripper (50%)

The signal should be maintained until the next change.

### 7.5 Control via the USB Connection

The command G01 Xxx can be used to move to infinitely variable positions using a serial connection via the terminal program or software.

Commands M0 to M6 can be used to move to the stored positions.

To compensate for long hose lengths, you can use the precharge/discharge time pulse [ms] to generate full power at the start of the movement. Default = 20 ms. The baud rate is 115,200 bauds.

Command code	Activity	Example
GO1 [X(position) P(ms)]	- Go to 25 to 100% position	G01 X90 P30
G27	- Go to reference position	(= 50% = 0 bar)
G132 [A(pos1)] [B(pos2)] [C(pos3)] [D(pos4)] [E(pos5)] [F(pos6)]	- Store new gripper positions	G132 A35 B42 C50 D65 E80 F90
G133 [P(time)]	- Store precharge/discharge time in ms to EPROM, 1 m = 10 ms	G133 P20
M1–M6	- Go to defined position 1 to 6	—
M20	- Vacuum suction cup ON/OFF	
M21	- Vacuum suction cup auto ON	
M22	- Vacuum suction cup Auto OFF	
M40	- Version and status	
M65 [X(number)] [(de- lay)]	- Demo mode for testing	M65 X100 D250
M116	- Debug off	
M117	- Debug on (show feedback time)	

All commands must end with a line break.

## 7.6 Using the Software

**a)** GRIPPER POSITIONS: 40, 43, 50, 80, 90, 100. Buttons: -2, -1, 0, 1, 2, 3. Save Positions

**b)** TEST RANGE %: 43, 90. Buttons: Suction Cup ^, < Open, Reference v, Close >

**c)** SET AIR HOSE LENGTH [M]: 3. Save Length

The software is divided into three sections:

- GRIPPER POSITIONS:
- TEST RANGE %
- SET AIR HOSE LENGTH [m]

#### a) Section 1: Gripper Positions

Section for editing/changing the profiles and transferring them to the PLC.

2 profiles for opening the finger with a vacuum (range of 25 to 49)

Fixed neutral position (50)

3 profiles for closing the finger with pressure (range of 51 to 100)

GRIPPER POSITIONS:

40	43	50	80	90	100
-2	-1	0	1	2	3

Save + transfer new profiles to PLC

Save Positions

- Changing parameters:** Click the dark blue area to change the parameter. The light blue bar is displayed on the cursor position. The number shows the control position.



- Activating the finger gripper:** Activate the finger gripper by clicking its corresponding button. In the example, clicking button 2 activates closing with level 2.

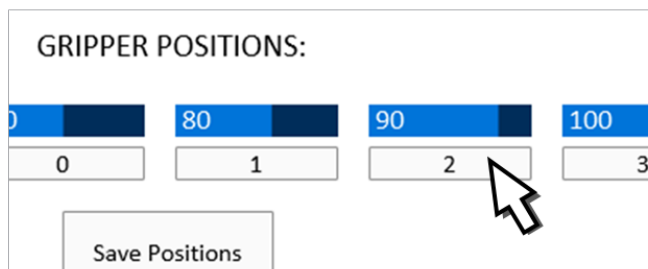

## b) Section 2: Test Range

Section for testing the opening/closing of the finger gripper so that it can be stored in the profiles.

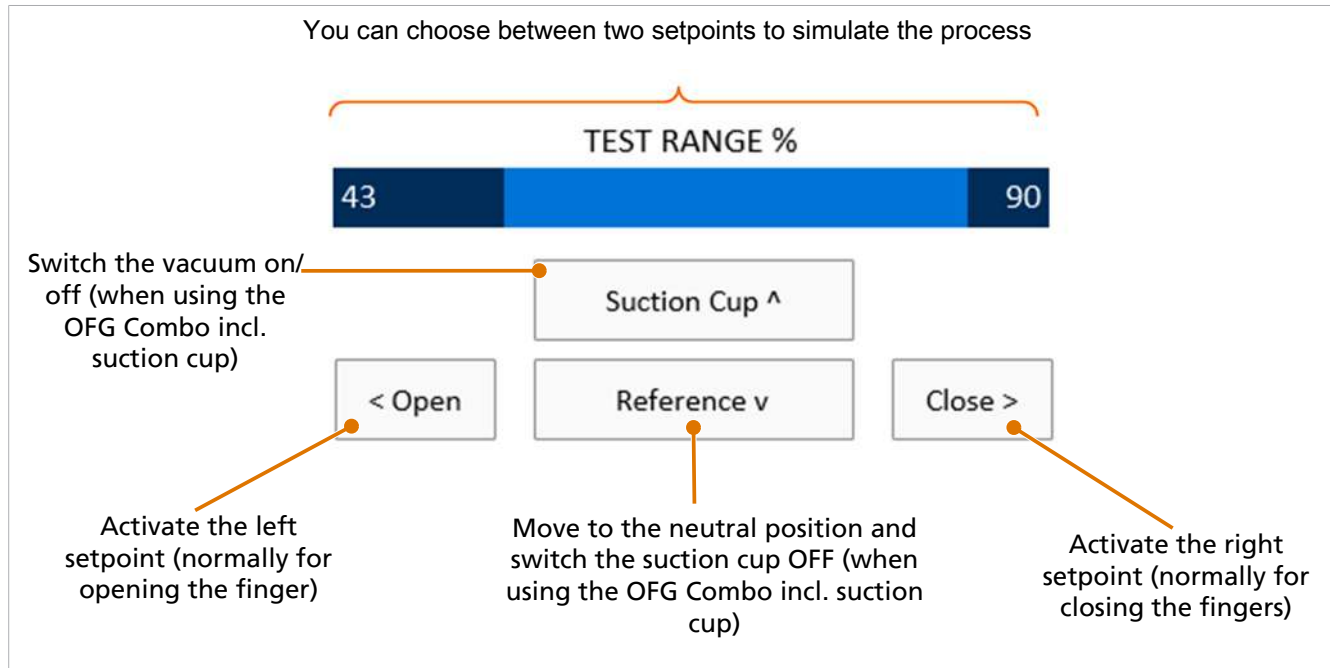

1. To change the parameters, click the highlighted positions in the light blue bar. You change the setpoints by moving them to the right or left. The number shows the control position.

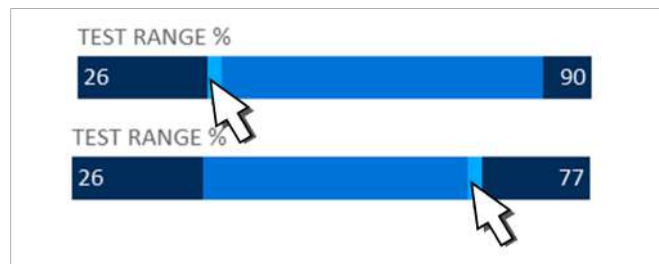

2. Alternatively, use the arrow keys on your keyboard to activate the various processes. This is indicated by the arrows next to the operation (^, v, >, <).

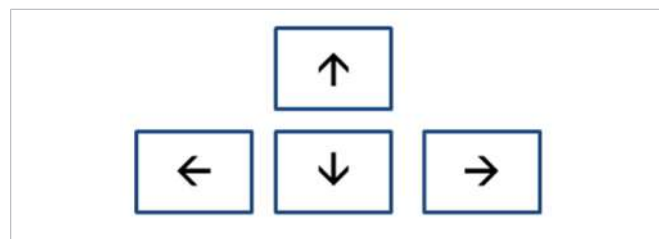

## c) Section 3: Set Air Hose Length

Adapt the gripper speed to the length of the pneumatic hose.



### ⚠ CAUTION

If the length entered for the pneumatic hose is too long, a gripping finger may break.

Risk of injury

- ▶ Correctly set the pneumatic hose length between the control device and gripper.
- ▶ Wear ear plugs and protective glasses.

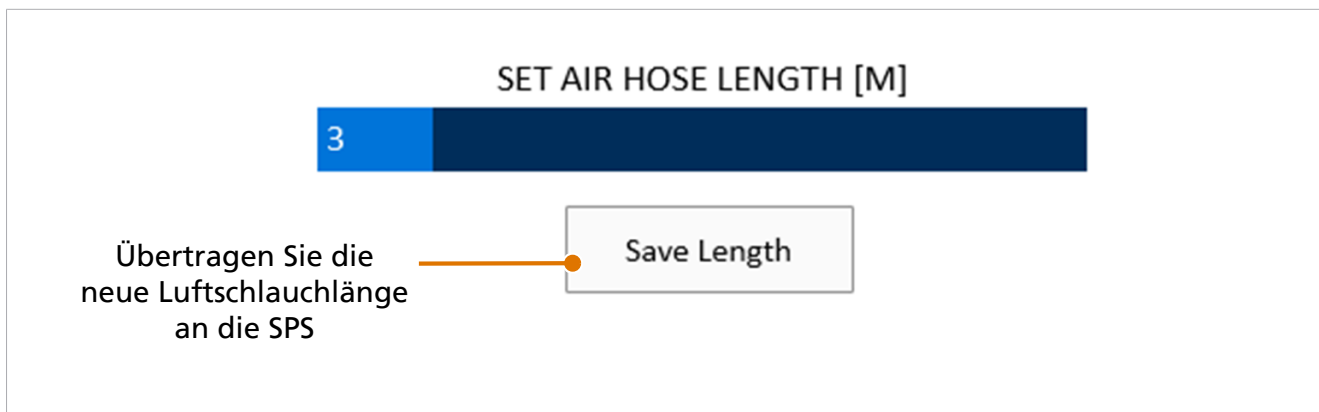

- ▶ Click the dark blue area to change the parameter. The light blue bar is displayed on the cursor position. The number shows the selected length for the pneumatic hose in meters [m].



## 7.7 Setting the Software

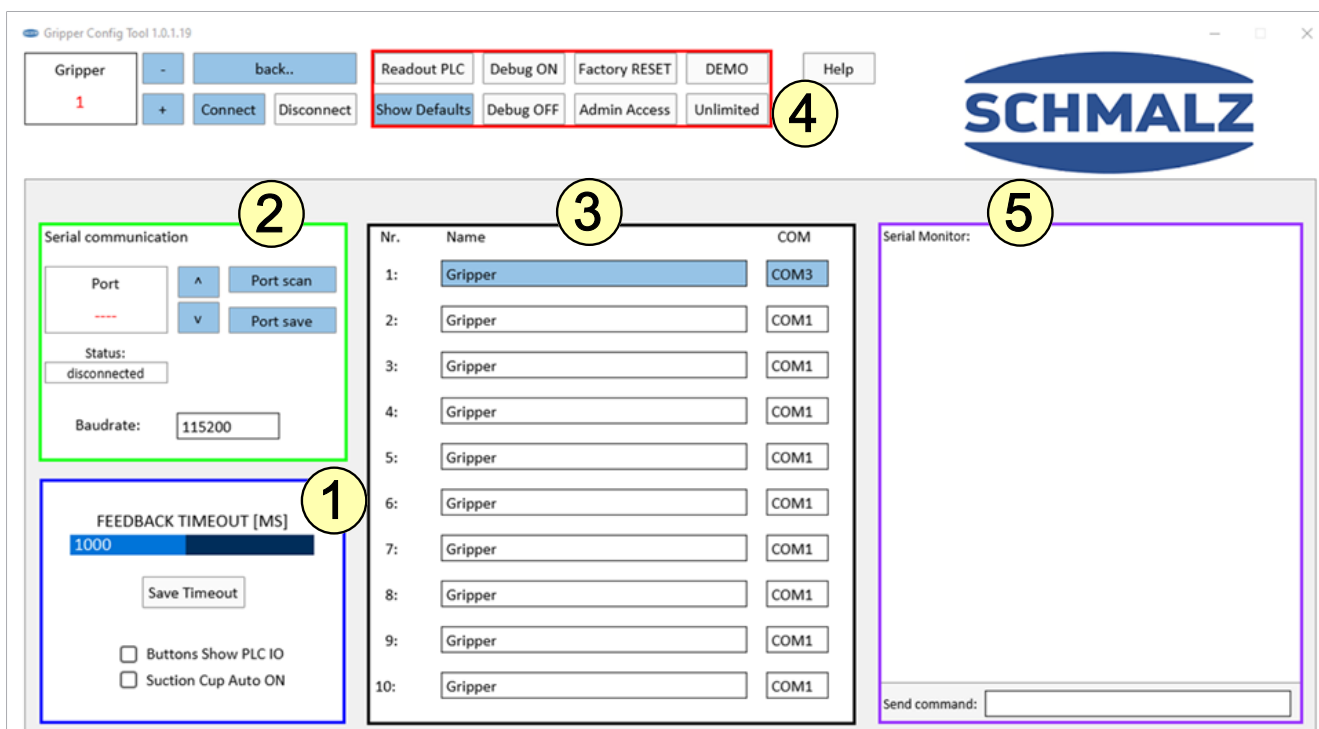

### 1. Area in blue frame: "Feedback Timeout"

This is the feedback time that the PLC "waits" until the valve sends a feedback signal to the PLC indicating that the set pressure is reached.

- If the valve reaches the set pressure within the set feedback time (default: 1000 ms), the following feedback is displayed:
  - 24 V via terminal DO06
  - Message on the serial monitor (purple area) with the actual feedback time (if debug mode was activated with the "Debug ON" button)

- If the valve does not reach the set pressure within the set feedback time, the following feedback is displayed:
  - 0 V via terminal DO06 (= no feedback)
  - Message on the serial monitor: “feedback: 1001 ms, 0%, ERROR, Target not reached”
  - The ERROR MESSAGE may be caused by the following reasons:
    - > Time exceeded due to the long hose length
    - > Leakage in the system

**“Buttons Show PLC IO” checkbox:**

For the wiring, the relevant I/O port information is displayed in the buttons.



**“Suction Cup Auto ON” checkbox:**

Switch the automatic vacuum and blow-off functions on or off. Please switch off if you control the suction cup using the external controller via I/O connections (standard).

**2. Area in green frame:**

If you choose “Scan,” the software uses all the COM ports assigned by Windows. Use “^” and “v” to switch between them and save the correct COM port to use the software. How do you know the COM port is the correct one? Open the Microsoft Windows Device Manager to display the devices that are currently connected. Search for “Arduino Mega” in the “Connections” section.

**3. Area in black frame:**

If more than one controller is used by a computer, you can specify and save ten different units. To change the unit, use the “+” and “-” buttons in the upper left corner.

**4. Area in red frame:**

The red area shows various buttons with different functions. The ability to use these buttons depends on the current status:

The controller is not connected

**Show Defaults:**

Click this button to display the default settings in the operating screen bar (however, they are not transferred to the PLC).



The controller is connected

**Readout PLC:**

Click this button to display the current PLC settings in the bars on the operating screen.

**Debug ON:**

Click this button to display the actual feedback time on the serial monitor (purple).

**Debug OFF:**

If you click this button, the actual feedback time is not displayed on the serial monitor (purple).

Administrator access is active**Unlimited:**

Enables 110% pressure (= 1.1 bar) for the controller, with a warning message "unlocked" on the monitor when the rotary switch is set to "3".

**ATTENTION:** If "Unlimited" is activated, there is no warranty claim or entitlement with regard to the service life/condition of a gripping finger.

**Factory Reset:**

Resets everything in the controller to the factory settings.

**DEMO:**

This starts demo mode, in which the gripper is opened and closed 10,000 times with a short idle time in between.

- Number of cycles: 10,000
- Gripping finger positions: Switches between position "-1" and position "2"
- Length of the pneumatic hose: as saved
- Waiting time between opening and closing: 200 ms

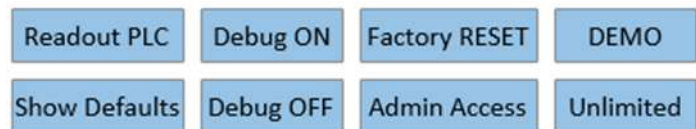
**5. Area in purple frame:**

The "Serial Monitor" displays the commands between the software and the controller. If an error occurs, this interface helps to generate a new setup and correct the error. Further commands can be entered in the "Send command" field to be executed using implemented buttons instead. (See the command overview or click the "Help" button.)

The following commands can be entered in the "Send command" text box:

Command	Explanation	Example
G01 [X(position) P(ms)]	Go to 25 to 100% position	G01 X90 P30
G27	Go to reference position	(= 50% = 0 bar)
G132 [A(pos1)] [B(pos2)] [C(pos3)] [D(pos4)] [E(pos5)] [F(pos6)]	Save new gripper positions	G132 A35 B42 C50 D65 E80 F90
G133 [P(time)]	Save the precharge/discharge time in ms, 1 m = 10 ms	G133 P20
G134 [T(time)]	Save feedback timeout in ms	
M1–M6	Go to defined position 1 to 6	
M20	Suction cup ON/OFF	
M21	Vacuum suction cup auto on	
M22	Vacuum suction cup auto off	
M40	Version and status	
M65 [X(number)] [D(delay)]	Demo mode for testing	M65 X100 D250
M116	Debug OFF	
M117	Debug ON (display feedback time)	



## 8 Maintenance Plan and Cleaning



### **⚠ DANGER**

#### **Electric shock from touching live components**

Serious injury or death!

- ▶ Make sure that the electrical components are not live before installation, maintenance and troubleshooting.
- ▶ Switch off the mains switch and secure against unauthorized restart.



Schmalz stipulates the following checks and check intervals. The operator must comply with the legal regulations and safety regulations applicable at the location of use. These intervals apply to single-shift operation. For heavier use, such as multi-shift operation, the intervals must be shortened accordingly.

Maintenance task	Daily	Weekly	Monthly	Every six months	Yearly
Check the general condition of the entire system before starting work. Perform a visual inspection for damage.	X				
Check the electrical installation and cable glands.					X
The operating instructions are available, legible, and can be accessed by personnel.					X



The type and frequency of cleaning is the responsibility of the operating company.

## **9 Warranty**

Schmalz guarantees this system pursuant to our General Terms and Conditions of Sale and Delivery. The same applies to spare parts, provided that these are original parts supplied by us.

Wearing parts are not covered by the warranty.

## 10 Accessories

Maintenance work may only be carried out by qualified personnel.



### **⚠ WARNING**

#### **Risk of injury due to incorrect maintenance or troubleshooting**

- ▶ Check the proper functioning of the product, especially the safety features, after every maintenance or troubleshooting operation.

<b>Designation</b>	<b>Part no.</b>
Connection cable ASK S-M8-4 2000 K-4P	21.04.05.00150
Connection cable ASK S-M12-5 2000 K-5P Turck WASS4.5-2/S366	21.04.05.00175
Power supply unit	21.07.01.00021
Pneumatic hose VSL 8-6 PU	10.07.09.00003
Connection cable ASK S-USB-A 2000 S-USB-B	21.04.05.00828

## **11 Taking the Product Out of Operation and Disposal**

If the product reaches the end of the utilization phase, it may be fully disassembled and disposed of. Only qualified specialist staff may prepare the product for disposal.

1. Fully disconnect the product from the power supply.
2. Dispose of the components properly based on their material groups.

For proper disposal, contact a company specializing in the disposal of technical goods and instruct the company to observe the applicable disposal and environmental regulations.

## 12 Declarations of Conformity

### 12.1 EU Conformity

#### *EU Conformity Declaration*

The manufacturer Schmalz confirms that the STEU-OFG products described in these operating instructions fulfill the following applicable EU directives:

2006/42/EC	Machinery Directive
2014/30/EU	Electromagnetic Compatibility
2011/65/EU	RoHS Directive

The following harmonized standards were applied:

EN ISO 12100	Safety of machinery — General principles for design — Risk assessment and risk reduction
EN 60204-1, 32	Safety of machinery – Electrical equipment of machines
EN IEC 63000	Technical documentation for the assessment of electrical and electronic products with respect to the restriction of hazardous substances



The EU Declaration of Conformity valid at the time of product delivery is delivered with product or made available online. The standards and directives cited here reflect the status at the time of publication of the operating and assembly instructions.

### 12.2 UKCA Conformity

The manufacturer Schmalz confirms that the product described in these operating instructions fulfills the following applicable UK regulations:

2008	Supply of Machinery (Safety) Regulations
2016	Electromagnetic Compatibility Regulations
2012	The Restriction of the Use of Certain Hazardous Substances in Electrical and Electronic Equipment Regulations

The following designated standards were applied:

EN ISO 12100	Safety of machinery — General principles for design — Risk assessment and risk reduction
EN IEC 63000	Technical documentation for the assessment of electrical and electronic products with respect to the restriction of hazardous substances



The Declaration of Conformity (UKCA) valid at the time of product delivery is delivered with the product or made available online. The standards and directives cited here reflect the status at the time of publication of the operating and assembly instructions.

---

## At Your Service Worldwide



---

### **Vacuum automation**

[WWW.SCHMALZ.COM/AUTOMATION](http://WWW.SCHMALZ.COM/AUTOMATION)

### **Handling systems**

[WWW.SCHMALZ.COM/EN-US/VACUUM-LIFTERS-AND-CRANE-SYSTEMS](http://WWW.SCHMALZ.COM/EN-US/VACUUM-LIFTERS-AND-CRANE-SYSTEMS)

---

**J. Schmalz GmbH**  
Johannes-Schmalz-Str. 1  
72293 Glatten, Germany  
T: +49 (0) 7443 2403-0  
schmalz@schmalz.de  
WWW.SCHMALZ.COM