



**Vacuum Training-Set**  
Manual

---

## Intended use

---

This learning system was designed and developed by the J. Schmalz GmbH for application in educational institutions. The educational institution and/or the instructor has to ensure that the safety arrangements that are defined in the instruction manual, on the data sheets and on CD-ROM in this manual attract interest by the trainees using this learning system.

The J. Schmalz GmbH excludes liability in any kind for injury of trainee, instructor and/or other people that occur beyond the training or wrong handling.

Article no.: 10.02.02.03043  
Type: **Schmalz Vacuum Training-Set**

The Vacuum Training-Set consists of in hand training manual, a CD-ROM and a corresponding parts kit in the product case.

© **J. Schmalz GmbH**, D-72293 Glatten, 2008  
Internet: [www.schmalz.com](http://www.schmalz.com)  
Email: [schmalz@schmalz.com](mailto:schmalz@schmalz.com)

Transmission as well as duplication – also digital –, application and communication of content are strictly prohibited. Exceptions have to be made in writing by the J. Schmalz GmbH.

Parts of this documentation are allowed to be copied for teaching purpose only.

---

<b>Content</b>	<b>Page</b>
<b>Part 1 General information .....</b>	<b>I</b>
Preface .....	I
Introduction .....	II
General safety- and working instructions .....	III
Composition of tutorials .....	IV
Parts kit.....	VI
Circuit diagram symbols .....	XII
Classification of components and tasks .....	XIII
<b>Part 2 – Exercises .....</b>	<b>15</b>
List of exercises .....	15
<b>Part 3 – Solutions .....</b>	<b>68</b>
Table of solutions .....	68
<b>Part 4 - Attachment.....</b>	<b>94</b>
List of appendices.....	94

---

## Preface

---

Nowadays vacuum plays a decisive role in many application areas and it is not possible to image our workday life without vacuum.

Wherever items, parts and packaging have to be lifted, hold, rotated or handled similarly, vacuum-technology offers solutions for implementations of automation process.

An easy theoretical definition of vacuum shows the operating mode of vacuum-systems. Vacuum is a state of a gas within a system whose pressure is lower than the atmospheric pressure or a state of a gas whose number of molecules is lower than the number of molecules in the atmosphere at the earth's surface. The pressure difference that affects a defined area causes the force necessary for handling operation. The experiment "Magdeburg's hemispheres" by Otto von Guericke from 1654 is one of the most impressive experiments in the history of vacuum.

The use of vacuum technology boosted enormously in the last decades in different areas and branches and will gain in importance in the future when levels of automation are rising.

At this juncture the metal and sheet fabricating industry as well as the packaging, wood, CD/DVD and plastics industry are to accentuate. Glass handling, logistics, electronics and the solar branch exhibit further application areas.

Through widespread use of vacuum technology there is a huge necessity for basic knowledge and practical experience in the vacuum technology already in education. The J. Schmalz GmbH, a leading provider of vacuum-technology, developed present Vacuum Training-Set to fulfill these requirements.

The structural composition enables the user to learn more about vacuum-technology stepwise via theoretical and practical exercises. Thereby the user gains a substantiated basis to meet all requirements in working life.

---

## Introduction

---

The manual of the Vacuum Training-Set is part of the learning system **vacuum-technology** of the J. Schmalz GmbH. As a company that acts globally and offers innovative products and services, we provide our customers with efficient solutions tailored precisely to their particular applications' requirements. We inspire our customers everywhere where production processes are designed more efficiently through the use of vacuum technology. The variety of workpieces that can be handled by the use of vacuum range from sensitive and small items such as electronic parts or CDs to parts of furniture or heavy sheet metal. Schmalz offers solutions for a wide range of industries such as automobile, CD/DVD, chemical, glass, wood, packaging, plastics and metal industry.

The present learning system tries to give an understanding of vacuum technology to the user. It is geared to different educational options and professional demands of user. The user gains basic knowledge regarding vacuum as well as basic functions due to the modular composition of the training-set including three tutorials. The most important topics of vacuum-technology are mentioned and important types of problems can be realized stepwise by means of this learning system.

Skills about physical basics of vacuum-technology as well as functions and application of different vacuum components are mediated.

Posed questions can be carried out practically due to creation of simple vacuum systems by dint of a parts kit.

A work station fitted up with compressed-air and electrical power supply displays an important requirement for the installation and operation of the Training-Set.

The present manual contains setting of tasks for each tutorial. There is no need for additional components. Furthermore manuals and data sheets for several components are available that should be examined before practical solution and installation of the systems.

---

## General safety- and working instructions

---



### General safety instructions

- Any kind of work at the test preparation is only allowed supervised by an authorised and teached person!
- Any kind of work at the test preparation is only allowed when power supply is switched off (compressed-air, supply voltage)!
- General safety instructions, EN norms and the VDE guidelines have to be considered and followed!
- The data sheets and operation manuals are to be considered necessarily!
- The operation of components is only acceptable within specified capacity! Malfunctions as well as demolition can be the consequence!
- Opening of components is not allowed!
- Components are not to be used for security-relevant functions!
- The operation in explosive surroundings is not allowed. Fire and explosion hazards!



### Danger of compressed-air

- Disconnect the compressed-air supply and vent the system before working at the test preparation!
- Closed containers can explode by compressed-air!
- The maximum operation pressure of components (6 bar) is not to be exceeded!
- If a hose detaches the compressed-air supply has to be switched off! Risk of injury!
- Never look into the compressed-air or exhaust-air flow!
- Risk of injury for eyes !



### Danger of vacuum

- Disconnect the compressed-air supply and vent the system before working at the test preparation!
- Closed containers can explode by vacuum!
- Ejectors create heavy suction that can absorb hair and clothes.
- Never look into the suction connection if ejector is switched on! Eyes could be absorbed!
- If dust, oil mist, fumes, aerosols and so on are extracted against the intended use, these attain to the exhaust air and causes poisoning!
- Ejectors do not act for transportation of liquids.



### Danger of electricity

- Disconnect electrical supply before working at the test preparation!
- Operation of the whole test preparation and all components only via power pack with safety extra-low voltage (SELV) and safe electrical disconnection according to EN60204



---

## Composition of tutorials

---

Diverse educational aims are traced by modular construction and exercises that have to be carried out.

For this reason the Vacuum Training-Set is subdivided into three tutorials with four exercises each. Main educational aims of the tutorials are as follows:

**Tutorial I:**      Combination of several vacuum components to establish an entire vacuum gripping system

**Tutorial II:**      Gripping system modification to minimize cycle times

**Tutorial III:**      Reduction of air consumption by integration of an automatic air-saving function within the vacuum generator

Each tutorial is arranged in such a way that the test preparation required for the tasks is explained initially.

Hence, this test preparation can be used mainly for an entire tutorial. First of all the topic of the tutorial is treated calculative before the calculated results can be compared and confirmed by a test with the gripping system.

The structure of the tasks of each tutorial is as follows:

- Tutorial
  - Task
    - Description of educational aims
    - Background knowledge
    - Setting of task
    - Attachments, hints and/or basic conditions
  - Test evaluation

Following educational aims are traced by the learning system:

- Appropriate handling of compressed air and vacuum
- Acquisition of theoretical background of vacuum-technology
- Acquisition of basis for calculation of vacuum-systems
- Getting to know the components of a vacuum-system it's characters and application areas
- Programming of vacuum-components to adapt them to the handling task
- Combination of several components to an entire vacuum gripping system
- Selection of suitable components for certain applications
- Coordination of individual, interactive components
- Improvement and economic design of vacuum-systems
- Insertion of an automatic air-saving for individual application











## Parts kit

The parts kit conduces to practical combination of vacuum-systems. It is essential for the given tasks and educational aims and covers all important components of vacuum-technology. In addition, a compressed-air supply (5 bar) as well as a power supply is required for the construction of functional vacuum-systems.

A gripper system and a workplate equipped with components provide the basis for the practical treatment of tasks. These parts are arranged pre-assembled in the case. Therefore, the following parts kit is integrated into the gripper system and the workplate.

### Gripper system

Type	Article no.	Picture	Quantity
Gripper system (pre-assembled)	10.01.10.03616		1
Flat suction pad (round) PFYN 10.0 NBR	10.01.01.00279		4
Flat suction pad (round) PFYN 15.0 SI	10.01.01.00155		4
Flat suction pad (round) PFYN 20.0 HT1	10.01.01.11136		4
Bellows suction pad (round, 1.5 folds) FSGA 20.0 NBR	10.01.06.00390		4
Bellows suction pad (round, 1.5 folds) FSGA 25.0 SI	10.01.06.00402		4
Bellows suction pad (round, 1.5 folds) FSGA 33.0 HT1	10.01.06.00957		4
Bellows suction pad (round, 2.5 folds) FSG 18.0 NBR	10.01.06.00026		4









Type	Article no.	Picture	Quantity
Bellows suction pad (round, 2.5 folds) FSG 25.0 SI	10.01.06.00337		4
Bellows suction pad (round, 2.5 folds) FSG 32 HT160	10.01.06.01246		4
Reduction nipple RED-NIP G1/4"-G1/8"	10.08.05.00139	<td>4</td>	4
Sealing ring DR G1/8	10.07.08.00020		16
Sealing ring DR G1/4	10.07.08.00021		6
Bulkhead connector SVS	10.08.03.00181		4
Plug-in connector STV-GE-G1/8-AG-6-4	10.08.02.00204		4
Plug-in connector G1/8"-IG	10.08.02.00150		1
Plug-in connector-T SVB-T 6	10.09.02.00021		1
Plug-in connector-T SVB-T 8	10.09.02.00022		1
Vacuum manifold VTR	10.09.03.00058		1

Type	Article no.	Picture	Quantity
Vacuum switch VS-V-D-PNP	10.06.02.00049		1
Choke valve	10.05.05.00090		1
Plug-in screw union VRS-STECC 8x38,4	10.08.06.00013		1
Plug-in union angle STV-W-G1/8-AG-6-4	10.08.02.00158		4
Plug-in union angle STV-W-G1/8-AG-8-6	10.08.02.00160		1
Vacuum- / compressed-air hose VSL 6-4 PU	10.07.09.00002		4x280mm
			2x50mm
Vacuum- / compressed-air hose VSL 8-6 PU	10.07.09.00003		2x80mm

## Workingplate

Type	Article no.	Picture	Quantity
Workingplate (pre-assembled)	10.02.02.03040		1
Compressed-air hose 1m	30.02.03.00228		1
Pressure reduction valve DM 0,5...10 bar	10.07.11.00019		1
Nipple	10.08.01.00027		1
Sealing ring DR G1/4 PA	10.07.08.00118		2
Double nipple DOP-NIP G1/4-AG	10.08.05.00133		1
Hand slide valve HSV	10.05.07.00034		1
Reduction nipple RED-NIP G1/4-G1/8"-AG	10.08.05.00139		1
Volume storage (1 Liter)	10.03.03.00132		1

Type	Article no.	Picture	Quantity
L-PROF-40x50x5x62 for mounting of pressure reduction valve	12.02.01.13061		1
Evacuation time counter	10.07.02.00043		1
Power pack for evacuation time counter	10.02.02.01581		1
Electromagnetic valve 3/2 NC	10.05.06.00052		1
Silencer SD	10.07.07.00002		1
Connection for electromagnetic valve	10.02.02.03250		1
Basic ejector SBP 10	10.02.01.00601		1
Basic ejector SBP 15	10.02.01.00602		1
Basic ejector SBP 20	10.02.01.00603		1
Compact ejector SCP 10 NC AS RD	10.02.02.00781		1
Insert for compact ejector	10.02.02.03251		1

Type	Article no.	Picture	Quantity
Sealing ring DR G1/8	10.07.08.00020		8
Sealing ring DR G1/4	10.07.08.00118		6
Plug-in connector STV-GE-G1/8-AG-8-6	10.08.02.00206		2
Plug-in connector STV-GE-G1/4-AG-8-6	10.08.02.00207		2
Plug-in connector angle STV-W-G1/8-AG-8-6	10.08.02.00160		7
Plug-in connector angle STV-W-G1/4-AG-8-6	10.08.02.00161		1
Plug-in connector angle STV-W-G3/8-AG-8-6	10.08.02.00236		1
Vacuum- / compressed-air hose VSL 8-6 PU	10.07.09.00003		1x1100mm 1x470mm 1x300mm 1x280mm 1x260mm 1x240mm
Samples / workpieces	each 250x250 mm	1x steel plate 1x cardboard (single-layer) 1x softwood 1x tile 1x chipboard	

## Circuit diagram symbols

Type	Symbol	Type	Symbol
Flat suction pad		Vacuum pressure switch	
Bellows suction pad		Filter	
Manometer		Pressure control valve	
Flexolink		Flow resistance	
Vacuum-controller		Basic ejector SBP 10/15/20	
Silencer			
Storage			
Hose line			

## Classification of components and tasks

Following overview demonstrates which components are used in which quantity for particular tasks. Hereby it is differentiated between components for the gripper system respectively for the workplate.

### Gripper system

Components	Exercises											
	1	2	3	4	5	6	7	8	9	10	11	12
Flat suction pad (round) PFYN 10.0 NBR			4	4								
Flat suction pad (round) PFYN 15.0 SI			4	4								
Flat suction pad (round) PFYN 20.0 HT1			4	4					4			
Bellows suction pad (round, 1.5 folds) FSGA 20.0 NBR	4		4	4			4					
Bellows suction pad (round, 1.5 folds) FSGA 25.0 SI			4	4							4	
Bellows suction pad (round, 1.5 folds) FSGA 33.0 HT1			4	4								
Bellows suction pad (round, 2.5 folds) FSG 18.0 NBR			4	4								
Bellows suction pad (round, 2.5 folds) FSG 25.0 SI			4	4								
Bellows suction pad (round, 2.5 folds) FSG 32.0 HT1			4	4								
Reduction nipple RED-NIP			4	4								
Bulkhead connector SVS	4		4	4			4		4		4	
Manifold VTR with vacuum manometer VAM	1		1	1			1		1		1	
T-manifold T-STK with vacuum switch VS-V-D-PNP	1		1	1			1		1		1	
Connection (for compact ejector)									1		1	
Electromagnetic valve 3/2 NC	1		1	1			1					
Connection (for valve)	1		1	1			1					
Plug-in connector SVB-T 8									1		1	
Choke valve											1	



Exercises													
	1	2	3	4	5	6	7	8	9	10	11	12	
<b>Components</b>													
Plug VRS-STECH 8x38,4												1	
Vacuum hose VSL 6-4 50 mm					1							2	
Vacuum hose VSL 8-6 80 mm									2			2	

## Workingplate

Exercises													
	1	2	3	4	5	6	7	8	9	10	11	12	
<b>Components</b>													
Compressed-air distributor	1		1	1	1		1		1		1		
Reduction nipple RED-NIP			4	4									
Manifold VTR with vacuum manometer VAM	1		1	1	1		1		1		1		
Volume storage (1l)	1		1	1	1		1		1		1		
Basic ejector SBP 10					1		1						
Basic ejector SBP 15					1		1						
Basic ejector SBP 20	1		1	1	1		1						
Compact ejector SCP 10 NC AS RD									1		1		
Connection (for compact ejector)									1		1		
Electromagnetic valve 3/2 NC	1		1	1	1		1						
Silencer SD	1		1	1	1		1						
Connection (for valve)	1		1	1	1		1						



---

List of exercises

---

TUTORIAL I:

Construction of a vacuum-system

- Combination of several components to establish an entire vacuum-gripping -

**Exercise 1** ..... 2

Construction of a vacuum-system ..... 2

**Exercise 2:** ..... 11

Theoretical calculation of holding force for suction pad selection ..... 11

Test evaluation for exercise 2: ..... 16

**Exercise 3:** ..... 19

Evaluation of vacuum levels ..... 19

**Exercise 4:** ..... 22

Test evaluation exercise ..... 25

Theoretical calculation of holding forces for suction pad selection ..... 70

## TUTORIAL II:

### Measuring of suction time and improvement of system - Gripping-system modification to minimize cycle times

<b>Exercise 5:</b> .....	<b>28</b>
Construction and configuration of a gripping system .....	28
<b>Exercise 6:</b> .....	<b>30</b>
Calculation of evacuation times and theoretical compressed-air consumption .....	30
Test evaluation exercise 6:.....	35
<b>Exercise 7:</b> .....	<b>39</b>
Measuring of evacuation time .....	39
Test evaluation exercise 7:.....	41
<b>Exercise 8:</b> .....	<b>44</b>
Cost analysis .....	44
Test evaluation exercise 8.....	48

## TUTORIAL III:

### Construction of a vacuum-system III

#### - Reduction of air consumption by integration of an automatic air-saving function within the vacuum generator -

<b>Exercise 9</b> .....	<b>52</b>
Construction and implementation of a gripper-system with automatic air-saving function .....	52
<b>Exercise 10</b> .....	<b>59</b>
Calculation of evacuation time and compressed-air consumption .....	59
Test evaluation exercise 10 a) .....	60
Test evaluation exercise 10 b): .....	61
<b>Exercise 11</b> .....	<b>62</b>
Calculation of evacuation times.....	62
Test evaluation exercise 11 .....	64
<b>Exercise 12</b> .....	<b>65</b>
Cost analysis and comparison of SCP and SBP .....	65
Test evaluation exercise 12.....	66

---

## Tutorial I

---

Tutorial I serves to give an introduction to vacuum-technology and to establish a general understanding for vacuum. Moreover main attention is on proper handling of commonly used vacuum components.

Tutorial I occupies the thematic frame of combination of several components to establish an entire vacuum gripping system. This tutorial is subdivided into four individual exercises.

At first a whole vacuum gripping system has to be set up. Several components are in attendance for the construction of a functional vacuum gripping system.

Afterwards the user can choose from a number of suction pads and workpieces. Particular holding and suction forces should be determined on the basis of calculations. These holding and suction forces assist to choose the accurate combination of suction pad and workpiece.

The chosen combinations should be proven with a test in practice subsequently.

With the last exercise of this tutorial the user is asked to determine a suction pad on the basis of criteria such as material, surface texture and stability of workpiece to guarantee an ideal handling within a production process.

At the end of tutorial I the user is in a position to design a vacuum-system with components necessary. The user is able to adjust to occurrences of the workpiece and to adapt the vacuum-system appropriate.



## Exercise 1:

### Construction of a vacuum-system

#### Educational aims:

- Proper construction of a vacuum gripping system with all associated components
- Knowledge about interaction of individual components within a gripping system
- Acquisition of functionality of several components within a gripping system

**Parts:** following parts are necessary for construction according to this exercise:

Gripper system	
Part	Quantity
Gripper system (pre-assembled)	1
Bellows suction pad (round, 1.5 folds) FSGA 20.0 NBR	4
Plug-in connection straight STVI-GE G1/8"-IG 6	1
Plug-in connection STV-GE-G1/8-AG-6-4	4
Bulkhead connector SVS	4
Vacuum/compressed-air hose VSL 6-4	1x 700 mm 4x 280 mm
Sealing ring DR G1/8"	4

Workingplate	
Part	Quantity
Workingplate (pre-assembled)	1
Compressed-air hose	1
Pressure reducing valve	1
Double nipple G1/4" AG	1
Reduction nipple G1/4"-G1/8" AG	1
Hand slide valve HSV	1
Plug-in connector compressed-air	1
Sealing ring DR G1/8"	1
Sealing ring DR G1/4"	1
Sealing ring DR G1/4" PA (red)	2
Evacuation time counter	1
Electric power supply / power pack	1
Plug-in connector STV-GE-G1/8- AG-8-6	2
Plug-in connector STV-GE-G1/4- AG-8-6	2
Plug-in connector STV-W-G1/8-AG- 8-6	7
Plug-in connector STV-W-G3/8-AG- 8-6	1
Plug-in connector STV-W-G1/4-AG- 8-6	1
Electromagnetic valve 3/2 NC	1
Silencer SD (for electromagnetic valve)	1
Insert for electromagnetic valve	1
SBP-10-G2-SDA	1
SBP-15-G2-SDA	1
SBP-20-G3-SDA	1
Vacuum/compressed-air hose VSL 8-6	1x1100 mm 1x260 mm 1x470 mm 1x280 mm
Volume VOL	1

Exercise 1: Construction of a vacuum-system		
Name:	Date:	
T I: Construction of a vacuum-system	Page 3 of 9	

## Background knowledge:

A vacuum gripping system, also called gripping system, is used for handling activities such as lifting, transportation, holding or turning of all types of items. A complete gripping system consists of different components. The gripping system considered in this exercise is a total operative vacuum system for automatic handling of workpieces included in this training-set.

Suction pads are the direct connection between the item that should be handled and the vacuum-system. Suction pads are vitally important for the functional capability of a vacuum-system. This circumstance will be deepened in tutorial I. The number of suction pads used is affected by attributes of the workpiece such as weight, inherent stability as well as parameters of the process such as acceleration. Type, size and material of the suction pads are chosen by different specifications that will be considered in exercise 2 and 3 of tutorial I. Four suction pads are suggested to use for the predetermined workpieces.

Suction pads are staked to the automation facility via mounting elements including fixed or flexible elements. Flexible elements are realized by ball joints or spring plungers for example. Fixed elements like profiles or holders are used for the direct adaptation of suction pads or other flexible elements. In this case only fixed elements are used.

Apart from the suction pads, vacuum generators are another essential component in a vacuum-system. It can be distinguished between electric and pneumatic vacuum-generators. Electric vacuum-generators are for example pumps and blowers that generate vacuum using electric energy. Pneumatic vacuum-generators operate with compressed-air exclusively and are also called ejectors, in narrower sense basic ejectors. They generate a vacuum on the basis of the so-called Venturi principle. Functions and physical background will be catered in tutorial II in detail. Furthermore ejectors can be fitted with additional functions; in this case they are called compact ejectors.

For the system available, a basic ejector is used. The ideal inlet pressure of the basic ejector can be adjusted via pressurestat. The ejector's supply pressure can be read off the manometer of the pressurestat.

To monitor and regulate the status of the vacuum-system, different components for system monitoring are in use. A manometer is used for system monitoring in present exercise.

For further exercises in tutorial II and III the adoption of a vacuum switch will be necessary.

Valves are used to control several functions of a vacuum-system. Therefore the compressed-air supply of an ejector can be interrupted and the vacuum-generation can be controlled consequently. Valves are also embedded directly into the vacuum-circuit so that individual suction pads or suction circuits can be actuated. If for example absorbed items should be laid down, the vacuum-connection of the suction pads can be interrupted and the suction pads can be vented. Electromagnetic valves that can be opened or closed via electric signals are widely used.

To control a basic ejector we will use an electromagnetic valve that is activated by the evacuation time counter.

Another kind of valves are those that are controlled manually. A hand slide valve can be used to control the compressed-air supply.

Vacuum hoses provide the connection between the vacuum-generator and the suction pads. As in the matter in hand one ejector and four suction pads are adopted, and a distributor is used to establish a connection between ejector and suction pads. Volume storages are attached to vacuum-systems to increase process reliability and to be able to realize energy saving control. They build up vacuum stocks, analogue to a compressed-air store. The volume storage is assembled among the vacuum-generator and the distributor in the system available.

Adjoining figure is one example for a simple vacuum-system. It is about a basic ejector which is directly connected to the compressed-air supply. Ejectors are endowed with a silencer to reduce sound level. An additional filter is adopted to the connection to the suction pad to defend the ejector from pollution. The vacuum level can be read off the manometer.

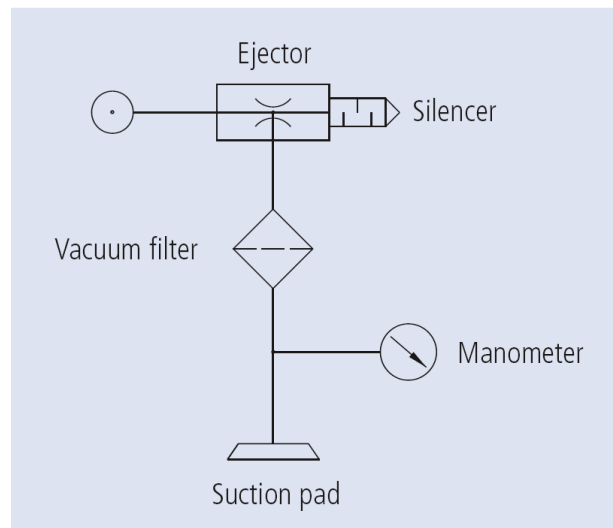





**Setting of task:**

Please arrange the vacuum-system described below with the aid of the description in the basic knowledge and the circuit diagram. The hints listed in the attachment display assistance.

**Circuit diagram:**

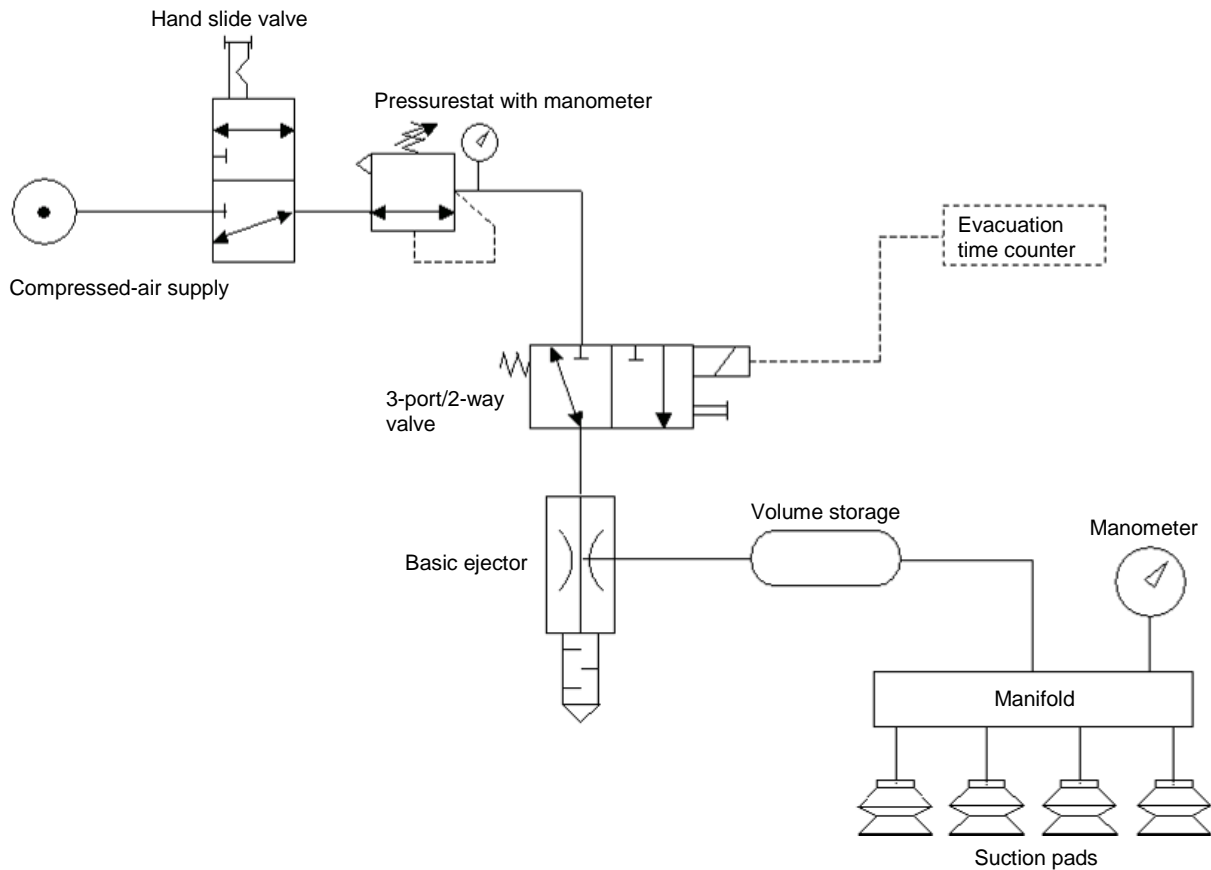

## Attachment:

The gripper system is arranged pre-assembled in the product case. This exercise should be for completion of the gripper system. Besides the workplate needed should be equipped.

The workplate will be inserted individually in the following exercises. That means all components will be assembled via hose connectors to a whole vacuum-system. In this exercise, the workplate will be equipped in such a way that it is preparatory work for further exercises.

For completion of the gripper system please follow the assembly instruction.

Adjoining figure shows the gripper systems' original state how you will find it in the product case.

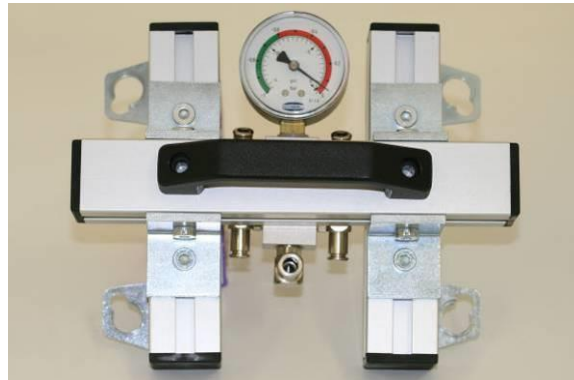

Please fix the bulkhead connectors (SVS-GE) to the holder with the aid of hex-nuts. The bulkhead connectors are cavity for the plug-in connectors (STV-GE) and the suction pads at the same time. Please attach them, too.

- STV-GE G1/8-AG 6 (4x)
- SVS-GE M16x1-AG (4x)
- Sealing ring (4x)
- FSGA 20.0 NBR (4x)

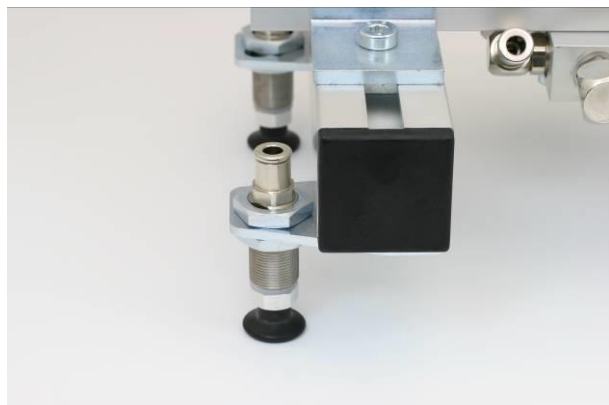

A vacuum distributor is used to realize the distribution of vacuum to the suction pads.

The suction pads are supplied with vacuum via clipped hoses from the distributor to the plug-in connectors on the bulkhead connectors. The bulkhead connector therefore displays the mounting of suction pads and is cavity for the hoses of the vacuum distributor at the same time.

Please connect all hoses VSL 6/4 (4x 280 mm length) with the plug-in connectors intended as the adjoining figure shows.

Please connect the hose VSL 8/6 (1x 1100 mm length) with the plug-in connector intended to realize the vacuum connection for the gripper system.

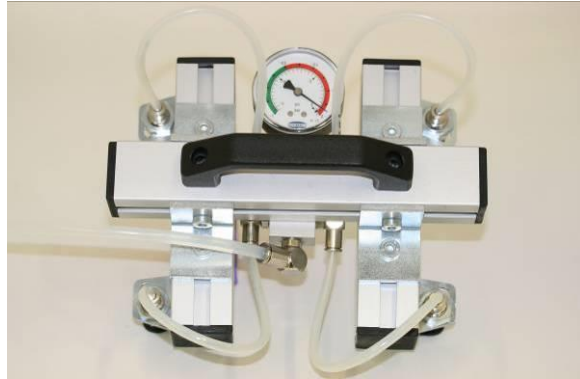

The present suction pads (FSGA 20.0 NBR) can be attached via pinning on the nipples. You will also need a reduction nipple for further exercises for the suction pads FSGA 32 HT1 and FSGA 33 HT1 to reduce the connection of the suction pad from G1/4-AG to G1/8-AG (see figure).



Please follow the assembly construction for completion of the **workplate**:

The workplate included is already mounted with all fixings for the components (see figure).

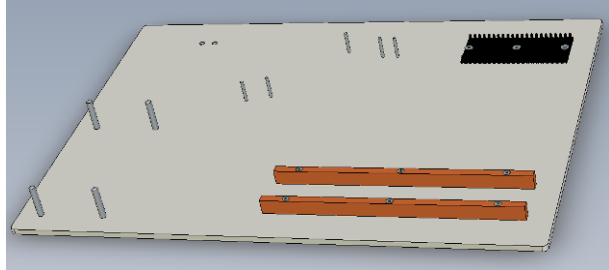

Please arrange the pressure reduction valve (see figure):

- Plug-in connector G1/4" (1x)
- Sealing ring PA G1/4" (2x) (rot)
- Double nipple G1/4" (1x)
- Hand slide valve HSV (1x)
- Reduction nipple G1/4"-G1/8"-AG
- Pressure reduction valve DM (1x)

Please mount the pressure reduction valve on top of the workplate afterwards (hole pattern top left). Use apposite L-profile and two M6x12 head screws for it. The pressure reduction valve can be connected to the L-profile via hex-nut (M30) afterwards.



Please fix the evacuation time counter to the workplate by sticking it to the four bolts. That applies to the electromagnetic valve (EMV) likewise.

Please fix the basic ejectors (SBP) to the fastening plate that is destined for it (top right).  
Please stick the vacuum storage (VOL) to the aluminum rails (bottom right).



For completion of the workplate please mount plug-in connectors (STV) to the components.

There are two different plug-in connectors:

- STV-GE (straight)
- STV-W (with angle of 90°)

Those are available with G1/8", G1/4" or rather G3/8" connectors.

The image should be help.



The electromagnetic valve (EMV) is activated by the evacuation time counter. Please connect the plugs of each color (correct polarity). The electromagnetic valve is closed in passive state (NC). By moving the switch of the evacuation time counter ("valve on") the EMV will be opened and compressed-air will channel to the basic ejectors.

The evacuation time counter is energized by a power pack (24 DC).

The compatible components have to be connected with each other to be able to treat with the following tasks. There is a variation in length of the hoses of VSL 8/6.

- 1100 mm (volume storage VOL with gripper system)
- 470 mm (electromagnetic valve EMV connection 2 with one ejector SBP)
- 280 mm (ejector SBP with VOL)
- 260 mm (pressure reduction valve with EMV connection 1) → connect the silencer to connection 3 of EMV

Exercise 1: Construction of a vacuum-system		
Name:	Date:	
T I: Construction of a vacuum-system	Page 9 of 9	

Please link following components for a first configuration of the workplate:

**Pressure reduction valve → Electromagnetic valve EMV → Basic ejector SBP 20 → Volume storage VOL**

The collocation of gripper system and workplate is the basic configuration for following exercises in tutorial I. This collocation is adjusted if required. Adaptations take the existing configuration as a basis.

If you followed the manual step-by-step the gripper system can be linked to the workplate now. Link the volume storage and the t-plug-in-connector at the vacuum distributor by the help of the vacuum hose (VSL 8/6).

The suction pads can be provided with vacuum when vacuum is generated. Therefore it is possible to suck workpieces with the gripper system.

Please check the assembly of your system by activating the compressed-air supply (5 bar) and turning the switch of the evacuation time to “valve ON”. The electromagnetic valve now let pass the compressed-air to the basic ejector SBP.

Try to suck enclosed steel plate and prove by the help of the manometer if a vacuum is generated. The display at the time measuring unit starts to run. For now don't pay attention to time measuring and interrupt the power supply after successful test by turning the switch to “valve OFF” and closing the hand slide valve.

Inspect your system with the help of following points if the vacuum level of about 600 mbar isn't reached:

- Prove all fittings, plug-in connectors and connections initiating at the suction pads
- Are the vacuum hoses linked close to the plug-in connectors?
- Is the choke valve at the gripper system closed and is the vacuum plug situated at the outcome of the valve?
- Ends enough compressed-air (5 bar) up from the pressure reduction valve at the ejector?

**WARNING:**

**Alterations at the connections are only to be carried out if the compressed-air supply is disconnected!**

If no vacuum can be generated by the vacuum generator please check the connections of components and whether valves are opened (hand slide valve as well).

## Exercise 2:

### Theoretical calculation of holding force for suction pad selection

#### Educational aims:

- To get to know occurring load cases in automated handling processes
- Calculation of holding forces of suction pads for different load cases
- Choice of suitable suction pads on the basis of calculation according to different load cases

#### Background knowledge:

It is important for an adequate choice of suction pads to determine characters of workpieces such as weight, kind of surface and ability to suck through the workpiece. Hence holding and suction forces that are needed can be calculated.

In vacuum-technology the user can differentiate between three different load cases that are consulted to calculate holding forces. You are supposed to determine a suitable combination of suction pad and workpiece with the help of technical descriptions for each suction pad and the characters of the workpiece. Initially the principle and functional mode of a suction gripper is exemplified and the formulas for calculation of each load case are illustrated afterwards.

#### Why does a suction pad hold a workpiece tightly?

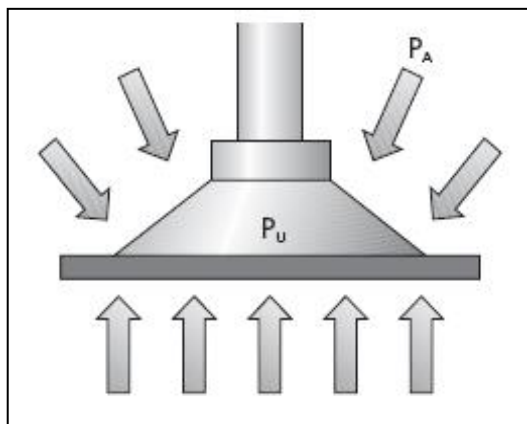

A suction pad does not attach itself to the surface of a workpiece. Instead, the ambient air pressure (atmospheric pressure) presses the suction pad against the workpiece as soon as the ambient pressure ( $P_A$ ) is greater than the pressure between the suction pad and the workpiece ( $P_U$ ). The bigger the pressure difference between ambient air pressure and pressure between suction pad and the workpiece the greater the resulting holding force.

$$P_U < P_A$$

### Calculation of holding and suction forces:

An adequate selection of suction pads is added to the holding forces of the suction pads.

In order to determine the holding forces it is important to know the mass  $m$  of the workpieces.

The mass  $m$  can be calculated with following formula:

$$m = L \cdot W \cdot H \cdot \rho$$

L = Length [m]

W = Width [m]

H = Height [m]

$\rho$  = Density [kg / m<sup>3</sup>]

In order to determine the holding forces required, we need to know the mass calculated above. In addition, the suction pads must be able to handle with the acceleration forces which, in a fully automatic system, are by no means negligible. In order to simplify the calculation, the three most important and most frequent load cases are shown graphically and described below. The theoretical holding force is the force necessary to hold the workpiece safely. A sufficient safety factor is included.

### Load case I – Suction pads horizontal, force vertical

$$F_{TH} = m \cdot (g + a) \cdot S$$

$F_{TH}$  = theoretical holding force [N]

$m$  = mass [kg]

$g$  = acceleration due to gravity [9.81 m/s<sup>2</sup>]

$a$  = system acceleration [5 m/s<sup>2</sup>]

$S$  = safety factor (minimum value 1.5; for critical, inhomogeneous or porous materials or rough surfaces 2.0 or higher)

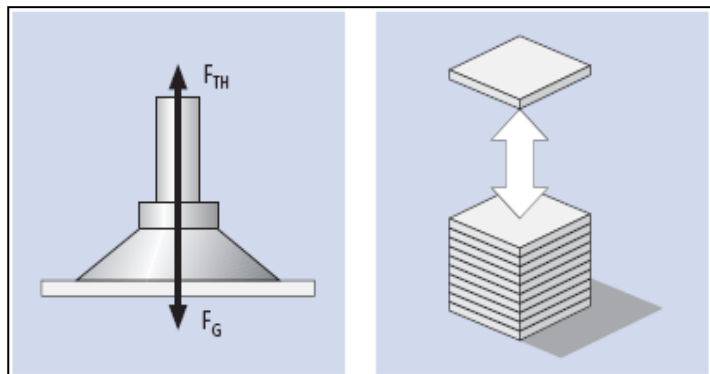



**Load case II – Suction pads horizontal, force horizontal**

$$F_{TH} = m \cdot \left( g + \frac{a}{\mu} \right) \cdot S$$

$\mu$  = coefficient of friction

- = 0.1 for oily surfaces
- = 0.2...0.3 for wet surfaces
- = 0.5 for wood, metal, glass, stone
- = 0.6 for rough surfaces

S = see load case I

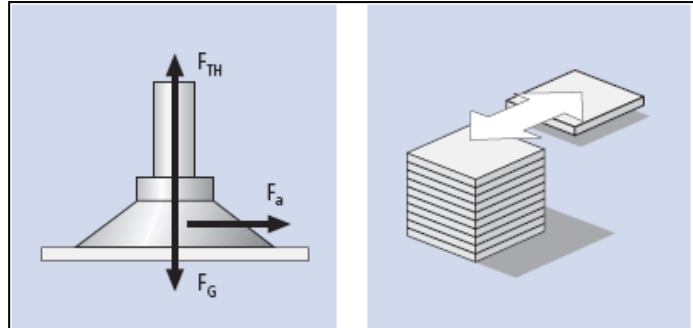

**Load case III – Suction pads vertical, force vertical**

$$F_{TH} = \left( \frac{m}{\mu} \right) \cdot (g + a) \cdot S$$

S = safety factor (minimum value 2.0; higher for critical, inhomogeneous or porous materials or rough surfaces)

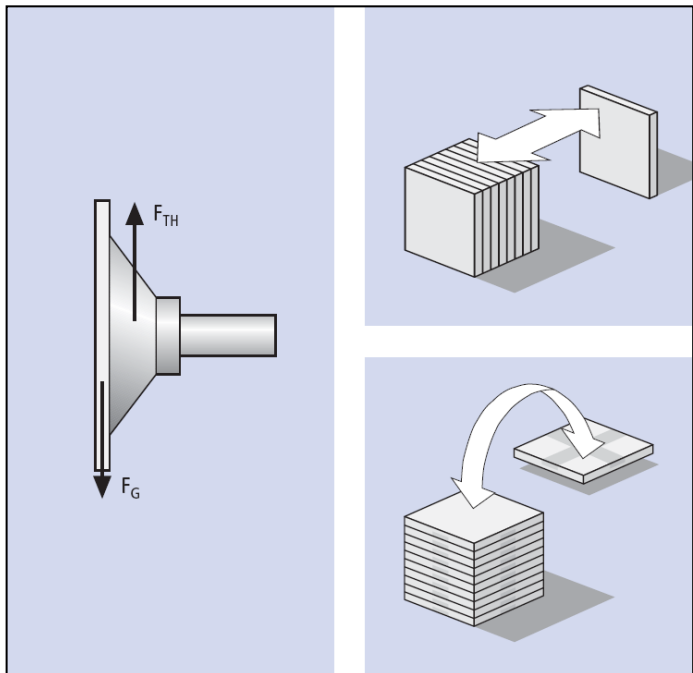

**Calculation of suction force  $F_S$  for each load case:**

$$F_S = \frac{F_{TH}}{n}$$

$F_S$  = Suction force per suction pad [N]  
 $n$  = number of suction pads [n=4]

### Definition of suction pad type:

Another aspect for the selection of the suction pad is the definition of type of suction pad. Depending on kind of surface specific types of suction pads are recommended. There are flat suction pads or bellows suction pads in principle.

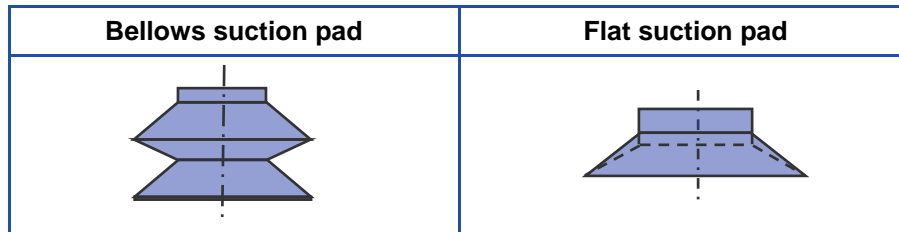

Flat suction pads are particularly suitable for handling of objects with flat or only slightly curved surfaces. For example sheet metal boards, cardboards, glass panels, plastic parts or wooden plates.

Bellows suction pads in contrast are used to handle parts with uneven or curved surfaces such as car body sheet, pipes and cardboards. Sensitive workpieces such as electronic components, injection molding parts or wrapped respectively shrink-wrapped items.

### Setting of task:

Please calculate mass  $m$  for each workpiece given in the attachment as well as the theoretical holding force  $F_{TH}$  and resulting suction force  $F_S$  for each load case. Choose adequate suction pads afterwards.

Following information is available:

- Characters of workpieces
- Technical data of suction pads

Please consider indications on product data sheets (page XIII)!

Results are **always** to be rounded up. The next higher value is always to be used.



### Attachment:

You need indications concerning material property for calculation of mass **m** which are listed in the table below:

Material property				
Type	Length [mm]	Width [mm]	Height [mm]	Density $\rho$ [kg / m <sup>3</sup> ]
Sheet metal	250	250	1.5	8000
Cardboard (single-layer)	250	250	3	145
Softwood	250	250	10	510
Ceramic	240	240	10	1940
Chipboard	250	250	10	670

You will need information on suction forces of the suction pads. These forces are listed in following table:

Technical data suction pads			
Type	Suction force FS [N]	Outside- $\emptyset$ [mm]	Inner- $\emptyset$ [mm]
PFYN 10.0	4.00	10.7	10.0
PFYN 15.0	9.00	15.8	15.0
PFYN 20.0	15.50	21.2	20.0
FSGA 20.0	4.70	18.3	18.1
FSGA 25.0	5.30	23.7	22.5
FSGA 33.0	13.60	33.0	30.0
FSG 18.0	2.30	18.5	17.2
FSG 25.0	4.50	24.7	23.0
FSG 32.0	12.00	32.6	32.0

### Note:

- Attention! All coefficients of friction denoted are averaged and have to be proofed for each workpiece.
- Choice of adequate suction pads is arranged depending on load case
- Please enter calculated values concerning mass of workpiece, holding and suction forces as well as suction pad types to sheet enclosed.

## Test evaluation for exercise 2:

### Theoretical calculation of holding force for suction pad selection

#### Calculation of mass of workpieces:

m<sub>Sheet metal</sub>: \_\_\_\_\_ kg  
 m<sub>Cardboard</sub>: \_\_\_\_\_ kg  
 m<sub>Softwood</sub>: \_\_\_\_\_ kg  
 m<sub>Ceramic</sub>: \_\_\_\_\_ kg  
 m<sub>Chipboard</sub>: \_\_\_\_\_ kg

#### Calculation of theoretical holding forces $F_{TH}$ :

Load case	I		II		III	
Workpiece						
Sheet metal	S:	N	μ:	N	μ:	N
			S:		S:	
Cardboard	S:	N	μ:	N	μ:	N
			S:		S:	
Softwood	S:	N	μ:	N	μ:	N
			S:		S:	
Ceramic	S:	N	μ:	N	μ:	N
			S:		S:	
Chipboard	S:	N	μ:	N	μ:	N
			S:		S:	



**Calculation of suction force  $F_S$  for each load case:**

Load case	I	II	III
Workpiece			
Sheet metal	N	N	N
Cardboard	N	N	N
Softwood	N	N	N
Ceramic	N	N	N
Chipboard	N	N	N

**Definition of suction pads on the basis of the calculations:**

	Chosen suction pad		
Load case	I	II	III
Workpiece			
Sheet metal			
Cardboard			
Softwood			
Ceramic			
Chipboard			

Test evaluation exercise 2		
Name:	Date:	
T I: Construction of a vacuum-system	Page 3 of 3	

### **Questions:**

#### Question 1:

Why is the holding/suction force of a flat suction pad (i. e. PFYN 20.0) higher than the holding/suction force of a bellows suction pad (i.e. FSGA 20.0) although the external diameter of the sealing lip of both suction pads is the same?

#### Answer:



## Exercise 3:

### Evaluation of vacuum levels

#### Educational aims:

- Ideal use of the gripper system
- Evaluation of a real achievable vacuum level of a system
- Handling and adjustment of working parameters (operating pressure, vacuum, ...)

Following components are necessary for construction and measuring of the vacuum-system in addition:

#### Components:

Component	Quantity
Flat suction pad (round) PFYN 15.0 SI	4
Flat suction pad (round) PFYN 20.0 HT1	4
Bellows suction pad (round, 1.5 folds) FSGA 20.0 NBR	4
Bellows suction pad (round, 1.5 folds) FSGA 25.0 SI	4
Bellows suction pad (round, 1.5 folds) FSGA 33.0 HT1	4
Bellows suction pad (round, 2.5 folds) FSG 18.0 NBR	4
Bellows suction pad (round, 2.5 folds) FSG 25.0 SI	4
Bellows suction pad (round, 2.5 folds) FSG 32.0 HT1	4
Reduction nipple RED-NIP	4
Samples / Workpieces	5

Several suction pads can be attached to the gripper system. The reduction nipples listed above are used to mount FSGA 33 HT1 and FSGA 32 HT1. Furthermore five different workpieces come into operation to carry out suction tests for workpiece handling.

By the help of a calculation the theoretical holding and suction forces are already determined before and hereupon adequate suction pads are chosen.

**Setting of task:**

Please scale the real achievable vacuum level for the load case by the help of combination of suction pad and workpiece determined in exercise two. Assure that the basic ejector SBP 20 is linked as vacuum-generator and that the operating pressure is 5 bar (adjustment via pressure regulator). The vacuum level can be read off the manometer now. The manometer has a break-up of 0.02 bar (20 mbar) and is subdivided into a green and a red block. Once the green block is reached a save handling is warranted. Please lift the gripper system not until this point in time for safety reasons.

Please enter the ascertained vacuum level into the table destined and evaluate the combination chosen in exercise 2 concerning the safety aspect of the handling process.

A vacuum level of at least -600 mbar is necessary for a save handling (green block).

**Note:**

- Please mind the indications in the operations manual for correct adjustment
- The workpieces are to test on the marked side only
- Check at different positions on the workpiece especially if the workpiece's surface is inhomogeneous
- Please enter the lowest value into the table if there is diverse measuring



### Test evaluation exercise 3:

#### Evaluation of vacuum levels:

Load case I		
Workpiece	Suction pad chosen	Vacuum level measured
Sheet metal		bar
Cardboard		bar
Softwood		bar
Ceramic		bar
Chipboard		bar



## Exercise 4:

### Choice of adequate suction pads

#### Educational aims:

- Actual-theoretical-comparison of theoretical values and measured values
- Critical reflection of measured values by help of failure analysis

Following components are available:

It is the same test preparation of workplate as in exercise 3. A SBP 20 is used as vacuum-generator as in the exercise before.

#### Components:

Component	Quantity
Flat suction pad (round) PFYN 15.0 SI	4
Flat suction pad (round) PFYN 20.0 HT1	4
Bellows suction pad (round, 1.5 folds) FSGA 20.0 NBR	4
Bellows suction pad (round, 1.5 folds) FSGA 25.0 SI	4
Bellows suction pad (round, 1.5 folds) FSGA 33.0 HT1	4
Bellows suction pad (round, 2.5 folds) FSG 18.0 NBR	4
Bellows suction pad (round, 2.5 folds) FSG 25.0 SI	4
Bellows suction pad (round, 2.5 folds) FSG 32.0 HT1	4
Reduction nipple RED-NIP	4
Samples / Workpieces	5

#### Setting of task:

A final inspection should be done to complete tutorial I. Again a test should verify the combination of suction pad and workpiece. Vacuum levels that can be reached with the suction pad and the workpiece should be measured.

Read off vacuum levels and enter them into the table intended. What attracts your attention when looking at your results? Why is the combination of workpiece and suction pad with the highest vacuum level not the ideal handling solution?

Exercise 4: Choice of adequate suction pads		
Name:	Date:	
T I: Construction of a vacuum-system	Page 2 of 3	

## Questions:

### Question 1:

In some cases a higher vacuum level is reached with a smaller suction pad than with a bigger one. What are possible reasons therefore?

### Question 2:

A vacuum level of at least -600 mbar is necessary for safe handling.

What kind of activities have to be undertaken that a porous workpiece with a vacuum level of about the -400 mbar can be handled securely?

Exercise 4: Choice of adequate suction pads		
Name:	Datum:	
T I: Construction of a vacuum-system	Page 3 von 3	

**Note:**

- Vacuum level:
  - No further tests are essential if a vacuum level of -600 mbar or more is hit. The vacuum level is high enough to warrant a safe handling. For that purpose the vacuum level should be gauged as close to the suction pad as possible (see test preparation).
  
- Shore hardness of suction pad:
  - The molding of the sealing lip has to fit to the surface of the material. That means a suction pad with soft sealing lip has to be chosen for textured workpieces.
  
- Further important criteria:
  - An unevenness of the workpiece affects the suction pad and causes abrasion
  - The suction pads' range of spring and flexibility as well as sealing attributes have to be adjusted to surface condition and structure consequently
  - Inherent stability affects adaptability of the suction pad
  - The diameter of a suction pad is determined by dimensions and weight of workpiece
  - Workpiece temperature influences material selection of suction pad (see catalogue of vacuum components in chapter 2 for it)
  - The acceleration of a facility has to be kept in mind when calculating theoretical holding forces

## Test evaluation exercise 4: Choice of adequate suction pads

### Answers:

Answer question 1:

Answer question 2:

### Evaluation of ideal suction pads:

Vacuum level measured in bar:

Suction pad	PFYN 10.0	PFYN 15.0	PFYN 20.0	FSGA 20.0	FSGA 25.0	FSGA 33.0	FSG 18.0	FSG 25.0	FSG 32.0
Workpiece / Material	NBR	SI	HT1	NBR	SI	HT1	NBR	SI	HT1
Sheet metal									
Cardboard									
Softwood									
Ceramic									
Chipboard									

---

## List of exercises

---

### TUTORIAL II:

#### Measuring of suction time and improvement of system - Gripping-system modification to minimize cycle times

<b>Exercise 5:</b> .....	<b>28</b>
Construction and configuration of a gripping system .....	28
<b>Exercise 6:</b> .....	<b>30</b>
Calculation of evacuation times and theoretical compressed-air consumption .....	30
Test evaluation exercise 6:.....	35
<b>Exercise 7:</b> .....	<b>39</b>
Measuring of evacuation time .....	39
Test evaluation exercise 7:.....	41
<b>Exercise 8:</b> .....	<b>44</b>
Cost analysis .....	44
Test evaluation exercise 8.....	48

---

## Tutorial II

---

Alongside suction pads, vacuum-generators are other vital components for a vacuum-system. Electrical vacuum-generators distinguish from pneumatic vacuum generators. Pumps and blowers are electrical vacuum-generators that excite vacuum using electrical energy. Pneumatic vacuum-generators in contrast operate with compressed-air exclusively.

These are ejectors that offer a compact design in contrast to electrical vacuum-generators. Moreover they are more cost-effective and considerably light due to their compact design. This is only one reason for using compact ejectors in automation nearly exclusively.

In addition to the determination of the suction pads required a proper functionality and choice of ejector is essential. This tutorial caters to the vacuum generation by using ejectors.

The heading of tutorial II is **modification of a gripping system to minimize cycle times in a process**. Components out of the vacuum-system of previous task are available. In addition there are different types of basic ejectors that are already mounted to the workplate (exercise 1). Firstly you are asked to calculate the corresponding evacuation times as well as the compressed-air consumption of various types of basic ejectors. The evacuation time is the time that is needed by an ejector to evacuate a suction pad to a defined vacuum level. As pneumatic vacuum-generators need compressed-air for vacuum generation the compressed-air consumption is named. An economic feasibility study can be carried out with these two values.

Afterwards the calculated values will be verified analogue to tutorial I by testing. A cost analysis of an automated handling process should be done to review the profitability of the basic ejectors in practice. Though a regulated basic ejector should be chosen on the basis of an exemplary process to make the most cost-effective and safest choice.

## Exercise 5:

### Construction and configuration of a gripping system

The basic system of tutorial I is necessary for tutorial II. However the gripper system has to be diversified. A digital vacuum switch is used for the first time. Known elements such as a manometer and vacuum switches are used in automated facilities mainly. They convert pressure signals into electrical signals which can be appraised by the control unit of the facility.

#### Components:

Component	Quantity
Vacuum switch VS-V-D-PNP	1
Vacuum/compressed-air hose VSL 6-4 50mm	2
Flat suction pad (round) PFYN 20.0 HT1	4
Bellows suction pad (round, 1.5 folds) FSGA 20.0 NBR	4
Bellows suction pad (round, 1.5 folds) FSGA 25.0 SI	4
Bellows suction pad (round, 1.5 folds) FSGA 33.0 HT1	4
Bellows suction pad (round, 2.5 folds) FSG 18.0 NBR	4
Bellows suction pad (round, 2.5 folds) FSG 25.0 SI	4
Bellows suction pad (round, 2.5 folds) FSG 32.0 HT1	4
T-distributor SVB-T6 (for vacuum hoses 6-4)	1

#### Background knowledge:

Digital vacuum-switches are used in all areas of automated handling such as in feeder systems in the automobile industry, in the plastics industry as well as other applications for raise of process safety.

Digital vacuum-switches monitor the vacuum level in the system and display a digital or analogue signal when predetermined (free programmable) levels are reached.

The VS-V-D has got two digital switching outputs. These are used to realize the air-saving function on the one hand and to guarantee an automated operation on the other hand. Therefore the vacuum-switch channels a release signal to the control to communicate the point of time for get-off to the gripper system.

Please find enclosed the operation instruction for further information as well as technical data.





**Test preparation:**

Affiliate the vacuum switch VS-V-D to one of the four suction pads to arrange a measuring as accurate as possible. Make use of the T-distributor (for VSL 6/4).

In addition you will need:

A plug-in connector to connect the vacuum hose to the vacuum switch STVI-GE (1x)



VSL 50mm (2x) for connection of T-piece to suction pad



Link the evacuation time counter to the vacuum switch at the suction pad.

The construction of the workplate will be retained unchanged.



## Exercise 6:

# Calculation of evacuation times and theoretical compressed-air consumption

### Educational aims:

- General understanding about the operation mode of basic ejectors
- Gather relationship between nozzle size and exhaustion rate respectively evacuation time
- Gather relationship between evacuation time and compressed-air consumption
- Choice of an adequate basic ejector

### Background knowledge:

Each company strives to keep processes and cycle times as short as possible to minimize operation costs. It has to be enlarged upon costs for a vacuum-system in order to be able to perform efficient with handling equipment. As not only purchase costs are decisive for the choice of an ejector it is important to find out the compressed-air consumption. These emerging costs have to be considered while looking at efficiency. An ejector's compressed-air consumption has to be kept low to minimize operation costs of the process. To minimize cycle times, evacuation time has to be minimized.

Evacuation time and compressed-air consumption have to be calculated and active influencing factors have to be inspected in this tutorial.

Ejectors are purely pneumatic vacuum generators which operate on the Venturi principle. A venturi nozzle consists of two cones directed against each other and unite in the middle at the smallest diameter. Liquids or gases pass through the nozzle; depression arises as well as a raise in flow velocity at the narrowest point of the tube (Bernoulli's law) without any additional and active impact. This law indicates that the velocity of the gas is the biggest where the profile is the smallest. According to the law of consistency for incompressible fluids the same amount of fluid escapes the tube that is inserted at the beginning. The bottleneck is passed by the same flow rate as the rest of the tube. Therefore the velocity has to increase at the bottleneck compulsory.

Hence the operation principle is as follows: Compressed air enters the ejector through the inlet (A) and flows through the Venturi nozzle (B). This accelerates and compresses the air. After leaving the nozzle, the air expands again, creating a partial vacuum. Air enters the ejector through the vacuum connection (D) and is ejected, together with the compressed air, through the outlet and the silencer (C).

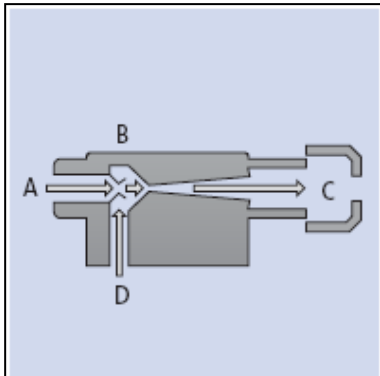

**Advantages of ejectors:**

- No moving parts, which means little maintenance and wear
- Compact construction
- No heat
- Low weight
- Fast generation of a vacuum
- Suitable for installation in any orientation

**Note:**

The nozzle diameter of the chosen ejector can be read off the appropriate indication in the table attached. Thus the nozzle of a SBP 15 has a diameter of 1.5 mm for example.

Following information is available for calculation of evacuation time and theoretical compressed-air consumption:

- Technical data and characters of three basic ejectors SBP 10/15/20
- Technical data for suction pads
- Characters of workpieces



**Setting of task:**

First of all calculate the evacuation time for the basic ejectors with the help of following formula:

$$t_{EV} = \frac{V \cdot \ln\left(\frac{P_a}{P_e}\right) \cdot 1,3}{V_{Ejector}}$$

$t_{EV}$  = evacuation time [h]  
 $\ln$  = natural logarithm  
 $V$  = volume to be evacuated [m<sup>3</sup>]  
 $P_a$  = initial absolute pressure [1013 mbar]  
 $P_e$  = final absolute pressure [mbar]  
 $V_{Ejector}$  = suction capacity of the vacuum generator [m<sup>3</sup>/h]

Emanate from the volume that has to be evacuated in the system. Please calculate the evacuation time for one liter in the unit [s/l] on the basis of your results.

Enter your results in the destined table. Enter the calculated values for  $t_{EV}$  [in s/l] in a diagram (see attachment). Use steel sheet as workpiece with the suction pad type PFYN 20.0 HT1.

It is advisable to do the calculations with the help of a Microsoft Excel based spreadsheet.

Compare your calculated values to the values out of our catalogue. What do you notice? Whereby can optionally arising deviations be justified? (Compare diagrams out of catalogue for this!)

Note that all values indicated in the catalogue are measured values because we provide our customers with real values out of practice corresponding to ejectors. Due to almost unavoidable deviations between theory and practice we try to avoid mistakes in system configuration that emerge from such deviations.

Please calculate the theoretical compressed-air consumption [in l] for an evacuation process by use of your calculated values for  $t_{EV}$ . Enter your results in the table.



Name:

Date:

T II: Measuring of suction time + improvement

Page 4 of 5

**Attachment:**

You will need those technical indications for different types of ejectors to calculate the evacuation time and the theoretical compressed-air consumption:

Technical data basic ejector SBP						
Type	Nozzle-Ø [mm]	Degree of evacuation [%]	Max. suction rate [l/min]	Max. suction rate [m³/h]	Air consumption during evacuation [l/min]	Air consumption during evacuation [m³/h]
SBP 10 SDA	1.0	85	37.7	2.3	48	2.9
SBP 15 SDA	1.5	85	71.0	4.3	105	6.3
SBP 20 SDA	2.0	85	127.0	7.6	197	11.8

Suction capacity at various degrees of evacuation in l/min									
Type	Degree of evacuation in mbar								
	0	-50	-100	-200	-300	-400	-500	-600	-700
SBP 10 SDA	37.70	33.20	30.10	26.70	23.00	18.60	14.90	9.80	5.20
SBP 15 SDA	71.00	65.00	60.10	52.00	44.00	36.50	29.00	20.50	11.40
SBP 20 SDA	127.00	117.80	106.00	94.20	79.10	65.30	49.87	35.99	23.00

Values out of catalogue for evacuation times for different vacuum levels s/l									
Type	Degree of evacuation in mbar								
	-50	-100	-200	-300	-400	-500	-600	-700	-800
SBP 10 SDA	0.06	0.14	0.30	0.52	0.82	1.30	1.98	3.26	6.56
SBP 15 SDA	0.05	0.08	0.16	0.26	0.40	0.60	0.86	1.30	2.54
SBP 20 SDA	0.03	0.05	0.09	0.16	0.24	0.34	0.49	0.80	1.74

**Diagrams out of catalogue:**

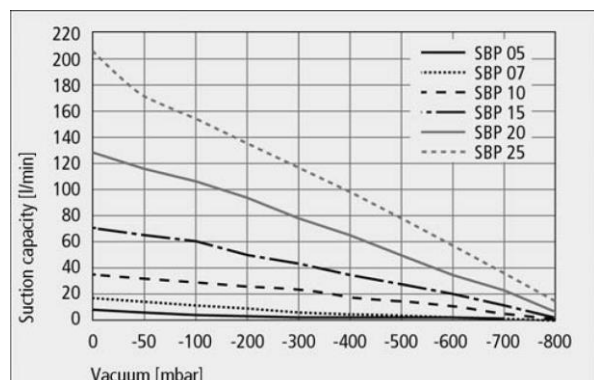
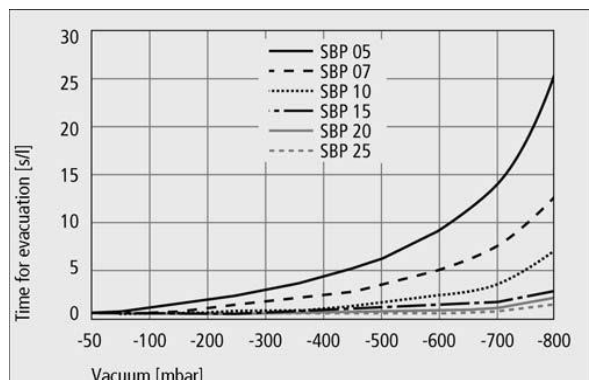



**Note:**

Note the contents in the volume storage, in the hoses and suction pads when calculating the evacuation time. The volume of plug-in connectors as well as electromagnetic valve is to be disregarded. The lengths of all relevant hoses are indicated in exercise 1. If there is an adaptation of hose length, the hoses should be measured again.

Volume of suction pads									
Type	PFYN 10.0	PFYN 15.0	PFYN 20.0	FSGA 20.0	FSGA 25.0	FSGA 33.0	FSG 18.0	FSG 25.0	FSG 32.0
Volume [cm <sup>3</sup> ]	0.07	0.40	0.80	1.15	3.15	4.75	1.35	5.40	10.00

**Further designations:**

Length of profile (volume storage):

$l = 250 \text{ mm}$

Cross sectional area hole (volume storage):

$A = 4000 \text{ mm}^2$



## Test evaluation exercise 6:

### Calculation of evacuation time and theoretical compressed-air consumption

**Volume suction pad (type: PFYN 20.0 HT1):** \_\_\_\_\_ cm<sup>3</sup>

(See designations in product sheets and table):

**Volume hose (6/4):** \_\_\_\_\_ cm<sup>3</sup>

**Length:** \_\_\_\_\_ cm

**Formula:**  $\Pi \cdot r^2 \cdot l$

**Volume hose (8/6):** \_\_\_\_\_ cm<sup>3</sup>

**Length:** \_\_\_\_\_ cm

**Formula:**  $\Pi \cdot r^2 \cdot l$

**Volume storage:** \_\_\_\_\_ cm<sup>3</sup>

**Total volume\*:** \_\_\_\_\_ cm<sup>3</sup>

\*Please mind that the total volume arises out of sum of suction pads, the hoses (only hoses to be evacuated) and the volume storage.



## Calculation of evacuation time:

### Basic ejector type SBP 10:

Calculation of evacuation time									
Degree of evacuation [mbar]	-50 mbar	-100 mbar	-200 mbar	-300 mbar	-400 mbar	-500 mbar	-600 mbar	-700 mbar	-800 mbar
Evacuation time for system volume [s]									
Evacuation time for 1 liter in [s/l]									
Evacuation time (out of catalogue) in [s/l]	0.06	0.14	0.30	0.52	0.82	1.30	1.98	3.26	6.56
Deviance									

### Basic ejector type SBP 15:

Calculation of evacuation time									
Degree of evacuation [mbar]	-50 mbar	-100 mbar	-200 mbar	-300 mbar	-400 mbar	-500 mbar	-600 mbar	-700 mbar	-800 Mbar
Evacuation time for system volume [s]									
Evacuation time for 1 liter in [s/l]									
Evacuation time (out of catalogue) in [s/l]	0.05	0.08	0.16	0.26	0.40	0.60	0.86	1.30	2.54
Deviance									

### Basic ejector type SBP 20:

Calculation of evacuation time									
Degree of evacuation [mbar]	-50 mbar	-100 mbar	-200 mbar	-300 mbar	-400 mbar	-500 mbar	-600 mbar	-700 mbar	-800 mbar
Evacuation time for system volume [s]									
Evacuation time for 1 liter in [s/l]									
Evacuation time (out of catalogue) in [s/l]	0.03	0.05	0.09	0.16	0.24	0.34	0.49	0.80	1.74
Deviance									





### Diagram of evacuation time for basic ejector SBP 15

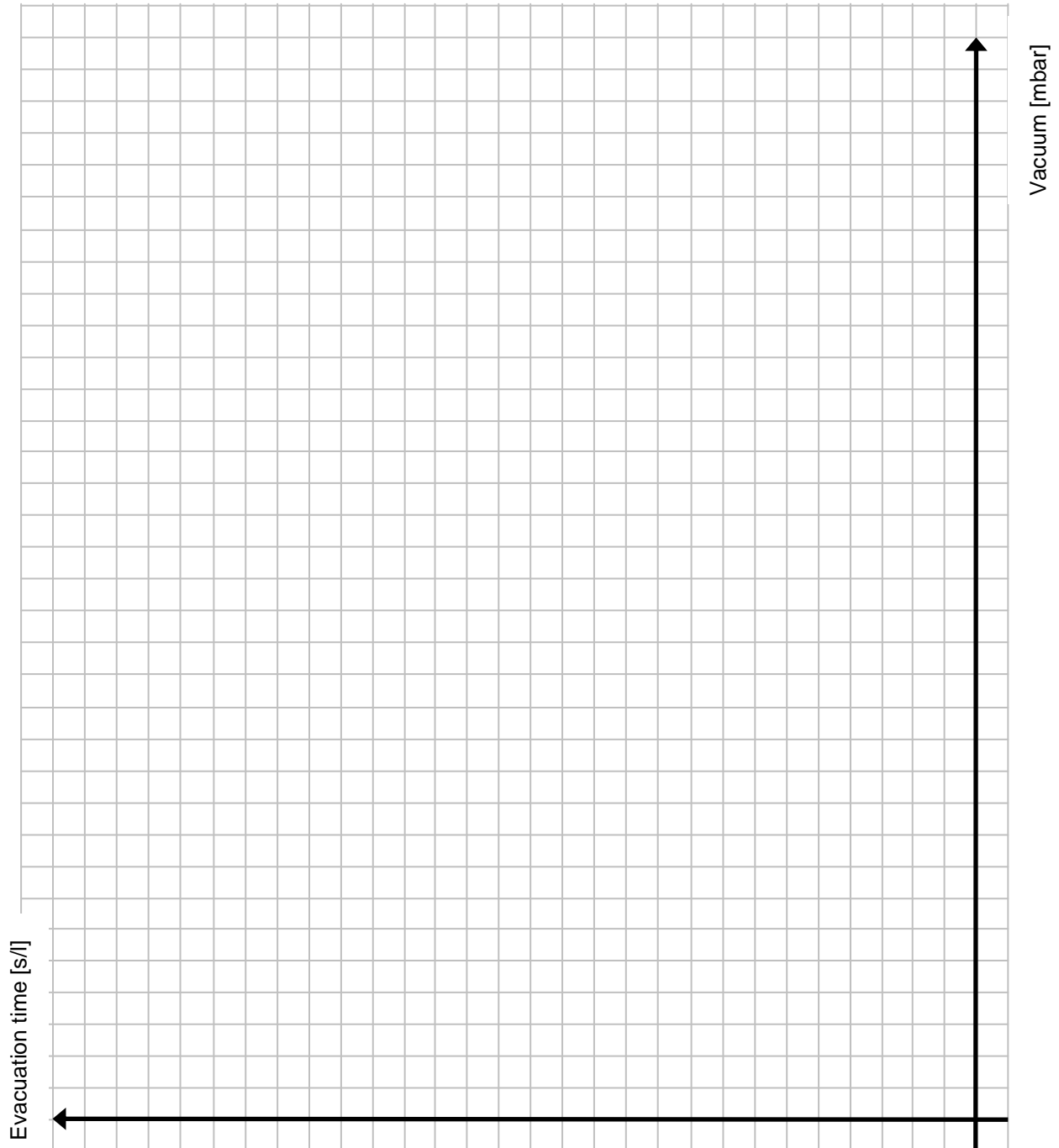



**Calculation of theoretical compressed-air consumption for evacuation process:**

**Basic ejector type SBP 10:**

(Air consumption during evacuation 48 l/min)

Calculation of theoretical compressed-air consumption [l]									
Degree of evacuation [mbar]	-50 mbar	-100 mbar	-200 mbar	-300 mbar	-400 mbar	-500 mbar	-600 mbar	-700 mbar	-800 mbar
Compressed-air consumption [l]									

**Basic ejector type SBP 15:**

(Air consumption during evacuation 105 l/min)

Calculation of theoretical compressed-air consumption [l]									
Degree of evacuation [mbar]	-50 mbar	-100 mbar	-200 mbar	-300 mbar	-400 mbar	-500 mbar	-600 mbar	-700 mbar	-800 mbar
Compressed-air consumption [l]									

**Basic ejector type SBP 20:**

(Air consumption during evacuation 197 l/min)

Calculation of theoretical compressed-air consumption [l]									
Degree of evacuation [mbar]	-50 mbar	-100 mbar	-200 mbar	-300 mbar	-400 mbar	-500 mbar	-600 mbar	-700 mbar	-800 mbar
Compressed-air consumption [l]									



## Exercise 7:

### Measuring of evacuation time

#### Educational aims:

- Verification of calculated parameters via tests
- Assembly of arrangements for system monitoring
- Execution of check measurements respectively system analysis that are common in practice
- Become acquainted with functional principle of vacuum switches

#### Setting of task:

The theoretical compressed-air consumption and the evacuation time for each ejector have been calculated arithmetically in the anterior exercise. In this exercise you are asked to measure the evacuation time by the help of a test.

The test preparation has already been established in exercise 5. The evacuation time counter should be used for the measurement of the evacuation time. As soon as the switch is at "valve ON" the evacuation time counter starts the measurement of time. Please ascertain that the display shows "0.000" before the measuring starts. For detailed information please read the operation manual of measuring instrument enclosed.

The measuring device needs a stop signal when a defined degree of evacuation is reached to measure the evacuation time. Digital vacuum switches are able to provide an electrical signal at a defined vacuum level (see exercise 5). This signal is named as H1 and the second signal is named as H2 in the menu of the vacuum switch. The switch-point H1 should give the signal to the evacuation time counter.

Consequently, three different degrees of evacuation have to be determined by the help of the switch for H1. Please read the operation manual enclosed for further information on programming of switch.

If the system is assembled in the right way and the programming is done well you are able to measure the time needed to evacuate the system now (various degrees of evacuation). For that purpose please regulate the degree of evacuation at switch-point H1 at the vacuum switch and read off die evacuation time.

Start your measuring with the ejector SBP 10 initially and carry out this test with two more ejectors SBP 15 and 20.

Exercise 7: Measuring of evacuation time		
Name:	Date:	
T II: Measuring of suction time + improvement	Page 2 of 2	

Use steel plate as workpiece and four suction pads type PFYN 20.0 HT1 for measuring. Enter your results into the table. Draw your results for ejector SBP 15 in a diagram (ordinate: evacuation time [s/l]; abscissa: degree of evacuation [mbar]. Compare your measurement to the theoretical value calculated before respectively to the values out of catalogue afterwards.

Compare the three diagrams of evacuation time as well. Where are the differences and why do they come out?

Arrange all measurements of evacuation time always three times and average over these measurements.



## Test evaluation exercise 7:

### Measuring of evacuation times

#### Basic ejector type SBP 10:

Measuring of evacuation time									
Degree of evacuation [mbar]	-50 mbar	-100 mbar	-200 mbar	-300 mbar	-400 mbar	-500 mbar	-600 mbar	-700 mbar	-800 mbar
Evacuation time for system volume in [s]									
Evacuation time for 1l in [s/l] (calculation with measured values)									
Evacuation time (values out of catalogue) in [s/l]	0.06	0.14	0.30	0.52	0.82	1.30	1.98	3.26	6.56
Evacuation times calculated in exercise 5									

#### Basic ejector type SBP 15:

Measuring of evacuation time									
Degree of evacuation [mbar]	-50 mbar	-100 mbar	-200 mbar	-300 mbar	-400 mbar	-500 mbar	-600 mbar	-700 mbar	-800 mbar
Evacuation time for system volume in [s]									
Evacuation time for 1l in [s/l] (calculation with measured values)									
Evacuation time (values out of catalogue) in [s/l]	0.05	0.08	0.16	0.26	0.40	0.60	0.86	1.30	2.54
Evacuation times calculated in exercise 5									

#### Basic ejector type SBP 20:

Measuring of evacuation time									
Degree of evacuation [mbar]	-50 mbar	-100 mbar	-200 mbar	-300 mbar	-400 mbar	-500 mbar	-600 mbar	-700 mbar	-800 mbar
Evacuation time for system volume in [s]									
Evacuation time for 1l in [s/l] (calculation with measured values)									
Evacuation time (values out of catalogue) in [s/l]	0.03	0.05	0.09	0.16	0.24	0.34	0.49	0.80	1.74
Evacuation times calculated in exercise 5									



### Diagram of evacuation time for basic ejector SBP 15

Ordinate: Evacuation time [s/l]

Abscissa: Vacuum [mbar]

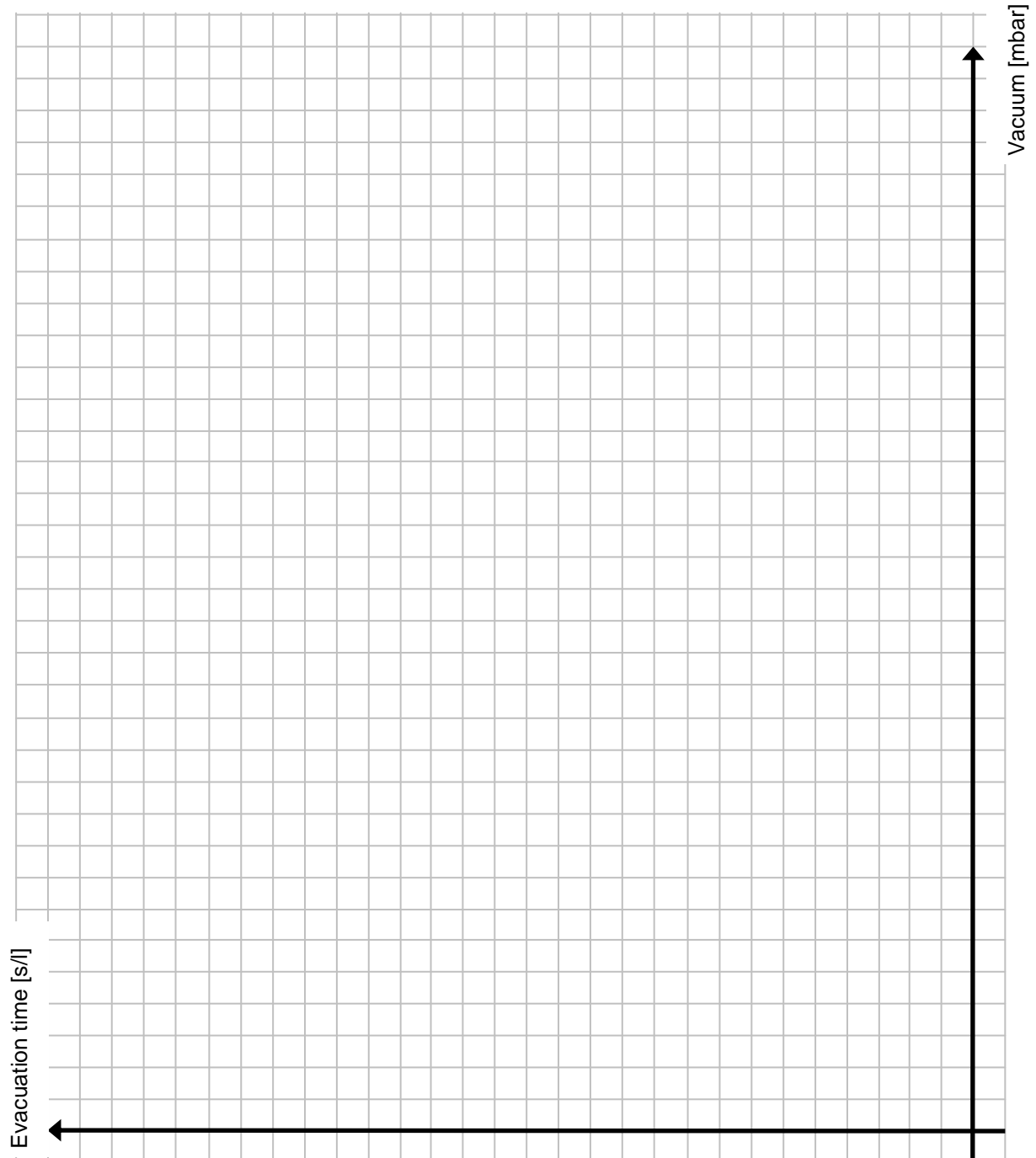

Test evaluation exercise 7		
Name:	Date:	
T II: Measuring of suction time + improvement	Page 3 of 3	

### **Comparison of results**

Differences to values calculated:

Reasons:



## Exercise 8:

### Cost analysis

#### Educational aims:

- To get to know motion-sequence of an industrial robot in an automated handling process
- Evaluation of operating costs of a vacuum gripping system

#### Setting of task

A metal-working company decided in favor of a vacuum-handling system. There are three basic ejectors available to generate vacuum. The most cost-effective ejector should be chosen by a cost comparison.

Stamping parts are produced in the company in double shifts of 8 hours per shift. You already dealt with the evacuation times of the ejectors in previous exercise.

The cycle of an automated handling process should start with the evacuation of the gripper system (the gripper system should already be placed on the workpiece). The workpiece will be lifted as soon as the required degree of evacuation of -600 mbar is reached. The lifting process will last one second.

The workpiece won't be accelerated by the dynamic of the robot and transported to its destination until the required degree of evacuation of -700 mbar is reached (in this case -700 mbar are estimated as essential depression for application with horizontal acceleration). The transportation process should last 6 seconds. Afterwards the robot needs one second to bring the workpiece down (vertically).

To bring the workpiece down on its destination the vacuum-generation is interrupted and the pressure in the system adapts to the atmospheric pressure (simplified description). Two seconds will pass until the workpiece is laid down safely. The robot reverts to its starting point afterwards (simplified directly to the next stamping part). Therefore it will need another two seconds.



Following diagram shows the procedure of the handling process of an industrial robot once more:

The horizontal motion-sequence of the robot should be explained by a v,t-diagram (velocity-time-diagram). The vertical movement of lifting respectively sagging of the workpiece is not demonstrated.

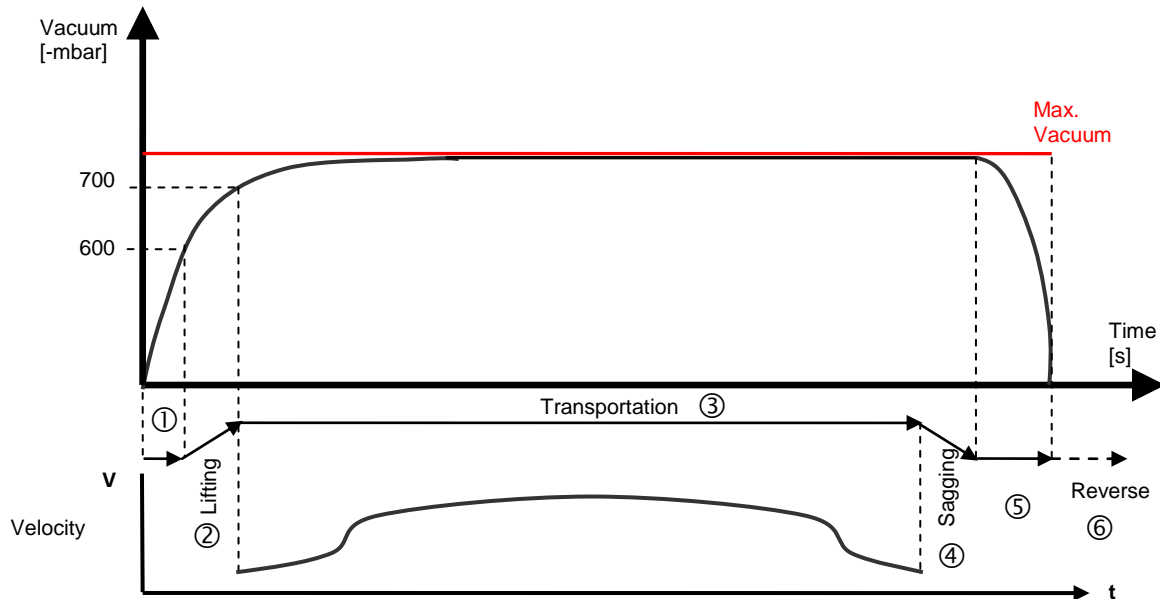

a) Determine the total cycle time for each ejector and the number of possible cycles on a workday out of it.

b) Calculate the total air-consumption for each ejector and the costs that accumulate for one workday in the company. Emanate from costs for compressed-air of about  $3 \text{ ct/m}^3$ . Include the evacuation time until a vacuum level of  $-700 \text{ mbar}$  is reached for calculation of operation costs.

c) Let's assume that the robot would be able to transport the workpiece already at low degrees of evacuation how much would be the costs for compressed-air for the evacuation process per workday then? Act on the assumption of 10.800 cycles a day uniformly and costs of compressed-air of about  $3 \text{ ct/m}^3$ .

Enter your results into the table and calculate the values for remaining degrees of evacuation

Exercise 8: Cost analysis		
Name:	Date:	
T II: Measuring of suction time + improvement	Page 3 of 4	

**Note:**

An evacuation process persists until the required degree of evacuation is reached to guarantee a safe handling respectively acceleration of the workpiece.

d) Question to the diagram:

Why is the robot able to lift the workpiece at a degree of evacuation of -600 mbar (vertical movement) but is not allowed to pick up velocity (horizontal movement) until the pressure in the system is dropped by another 100 mbar?

**Answer:**

Exercise 8: Cost analysis		
Name:	Date:	
T II: Measuring of suction time + improvement	Page 4 of 4	

**Attachment:**

You will need following technical data of basic ejectors for the cost analysis:

Technical data basic ejector SBP		
Type	Air consumption during suction process [l/min]	Air consumption during suction process [m³/h]
SBP 10 SDA	48	2.9
SBP 15 SDA	105	6.3
SBP 20 SDA	197	11.8



## Test evaluation exercise 8

### Cost analysis

- a) Total cycle time \_\_\_\_\_ [s]  
 Possible cycles per day \_\_\_\_\_ [cycles]

b)

#### Basic ejector SBP 10:

Operation costs								
Degree of evacuation [mbar]	-50 mbar	-100 mbar	-200 mbar	-300 mbar	-400 mbar	-500 mbar	-600 mbar	-700 mbar
Cycle time in [s]	X							
Possible cycles per day								
Air consumption per cycle in [l]								
Air consumption per day in [l]								
Operation costs per day in [ct.]								

#### Basic ejector SBP 15:

Operation costs								
Degree of evacuation [mbar]	-50 mbar	-100 mbar	-200 mbar	-300 mbar	-400 mbar	-500 mbar	-600 mbar	-700 mbar
Cycle time in [s]	X							
Possible cycles per day								
Air consumption per cycle in [l]								
Air consumption per day in [l]								
Operation costs per day in [ct.]								



**Basic ejector SBP 20:**

Operation costs								
Degree of evacuation [mbar]	-50 mbar	-100 mbar	-200 mbar	-300 mbar	-400 mbar	-500 mbar	-600 mbar	-700 mbar
Degree of evacuation [mbar]								
Cycle time in [s]								
Possible cycles per day								
Air consumption per cycle in [l]								
Air consumption per day in [l]								

**c)**

**SBP 10**

Costs [ct]									
Degree of evacuation [mbar]	-50 mbar	-100 mbar	-200 mbar	-300 mbar	-400 mbar	-500 mbar	-600 mbar	-700 mbar	-800 mbar

**SBP 15**

Costs [ct]									
Degree of evacuation [mbar]	-50 mbar	-100 mbar	-200 mbar	-300 mbar	-400 mbar	-500 mbar	-600 mbar	-700 mbar	-800 mbar

**SBP 20**

Costs [ct]									
Degree of evacuation [mbar]	-50 mbar	-100 mbar	-200 mbar	-300 mbar	-400 mbar	-500 mbar	-600 mbar	-700 mbar	-800 mbar

**TUTORIAL III:****Construction of a vacuum-system III****- Reduction of air consumption by integration of an automatic air-saving function within the vacuum generator -**

<b>Exercise 9</b> .....	<b>52</b>
Construction and implementation of a gripper-system with automatic air-saving function .....	52
<b>Exercise 10</b> .....	<b>59</b>
Calculation of evacuation time and compressed-air consumption .....	59
Test evaluation exercise 10 a) .....	60
Test evaluation exercise 10 b): .....	61
<b>Exercise 11</b> .....	<b>62</b>
Calculation of evacuation times .....	62
Test evaluation exercise 11 .....	64
<b>Exercise 12</b> .....	<b>65</b>
Cost analysis and comparison of SCP and SBP .....	65
Test evaluation exercise 12 .....	66

---

## Tutorial III

---

There is a multitude of possibilities to generate vacuum. Ejectors as pneumatic vacuum-generator represents a wide spread possibility. A distinction is drawn between basic, inline, multi-stage and compact ejectors. Each of these ejectors features specific characters.

Basic ejectors are the simplest type of ejectors (see tutorial I and II). They consist of a compact body with integrated Venturi nozzle basically. By connecting to compressed-air they generate vacuum permanently that can be controlled by interrupting the compressed-air supply.

On the contrary compact ejectors stand out for a variety of additional functions. They offer system monitoring, that is very convenient with extremely high cycle times. Integrated valve technology enables fast and safe blow-off by a blow-off impulse. Compact ejectors have an automatic air-saving function compared to basic ejectors. This function allows to control the compressed-air consumption within a process. If a desired vacuum level is reached the compressed-air supply is interrupted and thus there are no additional costs for compressed-air.

Compressed-air consumption is a very important expense factor in companies and especially in vacuum technology. Companies always try to boost their productivity by shorter cycle times and lower operation costs. On the one hand this happens by shorter evacuation times, by compressed-air savings on the other hand.

This can be reached to the compact ejector mentioned with automatic air—saving function. Due to the automatic air-saving function the compressed-air consumption can be interrupted if a freely programmed vacuum level is reached. Therefore a safe handling can be guaranteed nevertheless. If a minimum level is achieved the ejector readjusts so that the vacuum level required is generated again. The compressed-air consumption and therefore the operation costs can be reduced considerably by the use of an automatic air-saving function in automated processes.

The named character should be implemented in tutorial III reduction of compressed-air by integration of an air-saving control within the vacuum generator. At first a vacuum-system with a compact ejector should be constructed. To define the differences between a basic ejector and a compact ejector with automatic air-saving in detail, a comparison (by calculation and test) is to be done.



## Exercise 9:

# Construction and implementation of a gripper system with automatic air-saving function

### Educational aims

- Construction of a gripper system with air-saving function
- Adoption to function of an automatic air-saving function of a compact ejector
- Programming and ideal application of a digital vacuum switch

### Components

Following components are necessary for this exercise:

Components	Quantity
Flat suction pad (round) PFYN 20.0 HT1	4
Choke valve	1
Plug VRS-STECC (for choke valve)	1
Vacuum-generator compact ejector SCP 10 NC AS RD	1
Connection hose (for compact ejector)	1
Vacuum-/compressed-air hose VSL 8-6 (80 mm)	2
Vacuum-/compressed-air hose VSL 8-6 (260 mm)	1
Vacuum-/compressed-air hose VSL 8-6 (240 mm)	1
Samples / workpieces: steel plate	1
T-connector SVB-T 8	1



### Background knowledge:

Anterior exercises are all carried out with unregulated vacuum-generators. Basic ejectors expend ongoing compressed-air during operation and generate a continuous vacuum. The control function results from the control of compressed-air supply.

The already existing gripper system with unregulated vacuum-generator should be modified into a regulated vacuum-system. A compact ejector type SCP 10 NC AS RD is available for this modification. The indication ND refers to the position of the valve “normally closed”. Compared to NO (“normally open”) no vacuum is generated if the ejector is connected to compressed-air. AS means that the ejector is arranged with a bleed valve and a safety check valve. Therefore it is possible to channel the compressed-air to the connected suction pads. Safety check valve enables that the generated vacuum is held during automatic air-saving. The term RD means that there is an automatic air-saving with a digital vacuum-switch included.

Following figure shows the schematic construction of a compact ejector SCP. The main difference to a basic ejector consists in the components such as vacuum switch, bleed and suction valve.

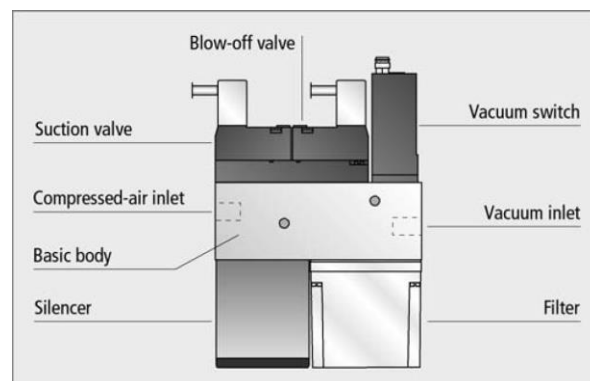

This compact ejector consists of automatic air-saving to save compressed-air and therefore to save costs during operation. Another attribute is the blow-off function. Hereby compressed-air is channeled well-directed to each suction pad to accelerate the repositioning. Therefore the repositioning process of workpieces can be minimized and the whole handling process can be accelerated. To be able to realize this, compact ejectors have an integrated valve technology. Two valves control grip and blow-off impulse. Those valves can be controlled directly or independently. That happens due to the integrated vacuum-switch, respectively due to an external control function.

The function „suction“ is activated if the ejector is switched-on until a preset value is reached. The air-saving automatic begins afterwards by switching-on the function “no suction” via valve. This function lasts until a preset area is under-run. This is called “hysteresis”. If this area is abandoned the vacuum-generation is switched-on again. The compact ejector readjusts, that means it recovers the original value. In this way, the compressed-air consumption can be kept little compared to a basic ejector.

Following figure shows the comparison of two ejectors.

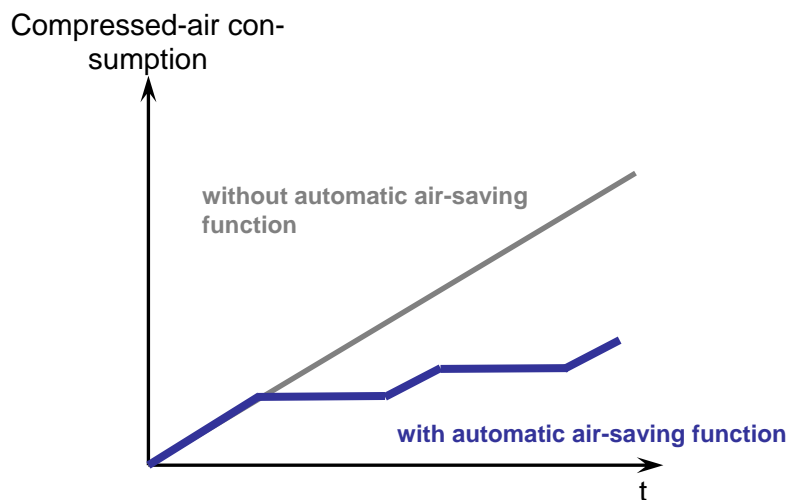

According to this, the course of vacuum level could look like this:

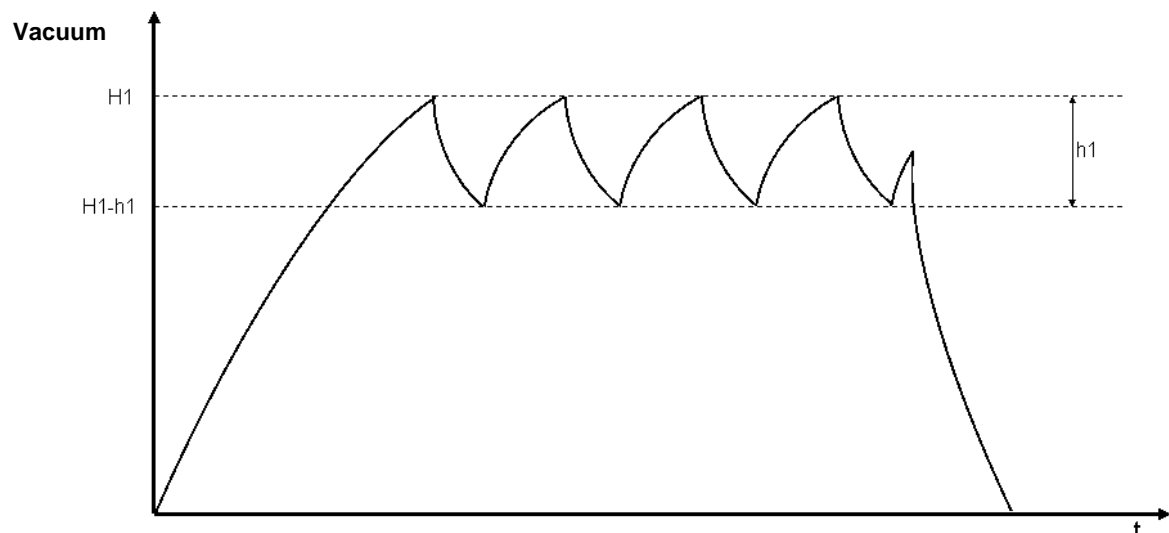

H1: Switching point 1 (switching point of automatic air-saving function; function “suction-off” is activated)

h1: Hysteresis (preprogrammed range where vacuum level can increase without readjustment of compact ejector)

H1-h1: Stop position of automatic air-saving function (“suction on” is activated when reaching this value; the ejector readjusts)

### Setting of task:

This task is about to alter the existing gripping-system into a regulated vacuum-system. The basic ejectors that were used so far and the valve 3/2 NC aren't necessary anymore to fulfill this task. They are replaced by the compact ejector SCO 10 NC AS RD which has an integrated blow-off and suction valve. Furthermore the appropriate connection cable for the compact ejector is necessary.

The workpiece to be handled is a **steel plate**. Four PFYN 20.0 HT1 are to be used as suction pads.

Following table serves to connect the compact ejector SCP 10 NC AS RD and to reconstruct the gripping-system:

Link the cable for the control to the compact ejector as follows:

- Connect the shorter cable of the grey ones (c) to the bleed valve (c).
- The longer cable (b) is for control of suction valve and has to be linked to connection b.
- The valves have to be controlled to adopt the automatic air-saving. This can be realized by linking the M8-connection (a) to the vacuum-switch of the SCP (connection a).
- The vacuum-switch that is connected to the gripper system should still be linked to the time measuring unit.

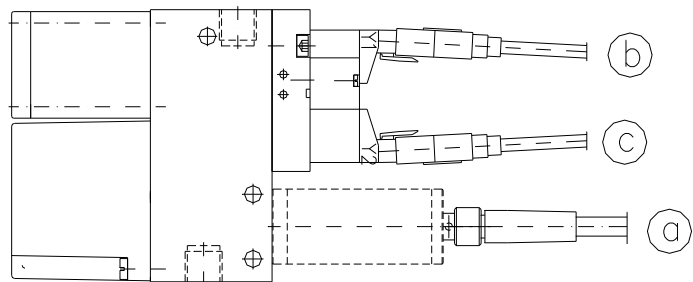
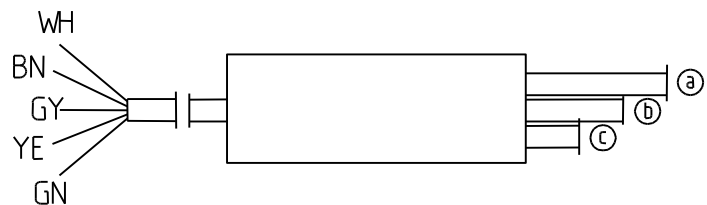

Link the pressure reduction valve and the compact ejector SCP (connection on side of silencer) to the compressed-air hose with a length of 260 mm.

The SCP and the vacuum storage (VOL) are connected by a vacuum hose with a length of 240 mm.

The present hose with a length of 1100 mm remains as connection of vacuum-storage and gripper system.

The completed workplate differs from the original one now as follows: The compact ejector SCP is in-between of the pressure reduction valve 3/2 NC and the vacuum-storage instead of the basic ejector.

The compact ejector SCP has two connections and is normally closed (NC); that means no vacuum is generated during compressed-air supply.

The suction valve has to be activated (24 V DC) to generate a vacuum. This is realized by the evacuation time counter.

The SCP is necessary for tutorial III.



Affiliate a choke valve in-between the volume storage and the gripper system as shown in the picture below. An artificial leakage can be simulated by the help of the choke valve.

Conjoin the choke valve to the T-plug-in-connector and the hose system at the gripper system. It is necessary to simulate a leakage in exercise 11.

Affix the closing plug to the choke valve.

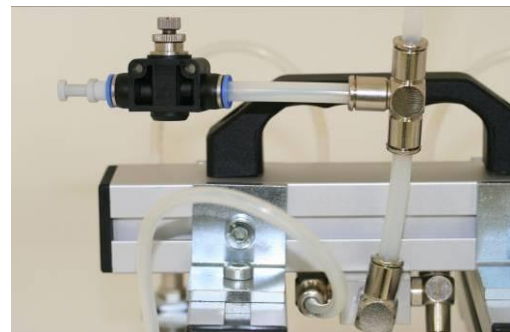

To use the automatic air-saving function ideally it is important to determine adequate switch-points and values for hysteresis. A value of about -700 mbar is suggestive as switch-point **H1**. This value has to be entered to the vacuum-switch with 0.7. An adequate hysteresis **h1** would be -50 mbar (shown as 0.05 on the vacuum-switch). You have to enter these values into the vacuum-switch that is directly assembled to the compact ejector SCP. Therefore please read the operations manual of the switch.

To be able to measure the evacuation time the vacuum-switch have to be programmed with the same switch-point H1 as the vacuum-switch of the compact ejector SCP.

Check the functionality of the whole system with the steel plate. Please care for that the choke valve is closed completely. The vacuum-generation should stop at -700 mbar now. As the workpiece is very leak-proof, the vacuum level won't decline.

You may open the throttle screw bit by bit now so as to reduce the vacuum level. As soon as the vacuum-level is about -650 mbar the vacuum-generation should start automatically. Depending on how wide the throttle screw is opened, the ejector readjusts shortly or after a short period of time.

If the automatic air-saving is tested successfully you can blow-off the steel plate now. During the blow process of workpieces the compressed-air is channeled directly to the suction pads to accelerate the blow-off of the workpieces in a handling process.

The activity of blowing can be realized by activating the bleed valve of the compact ejector SCP. The upcoming compressed-air is channeled directly to the exit of the ejector.

Install the plug of the connection cable for the SCP as follows:

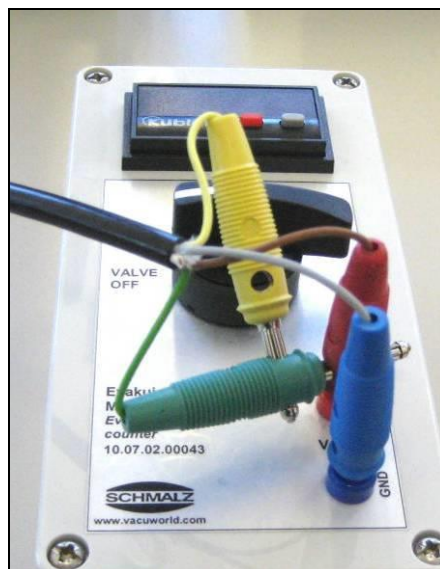

By connecting the green plug to +24 V (positive pole, red) the vacuum-generation is deactivated at pointed condition.



By connecting the yellow plug to +24 V the blow-off is activated. The upcoming compressed-air is conducted to the suction pads so that the workpiece can be blown-off.

The configuration of the electrical connections is as follows:

Red	=	Positive pole +24 V DC
Blue	=	Negative pole (ground)
Green	=	„Suction OFF“
Yellow	=	„Blow-off ON“
Black	=	digital output (+24 V)



## Exercise 10:

### Calculation of evacuation time and compressed-air consumption

#### Educational aims:

- Calculation of the evacuation time of a compact ejector
- Verification of measured values
- Calculation of compressed-air consumption of a regulated vacuum-system

#### Setting of task

a) The automatic air-saving function should begin ideal. An applicable switch-point as well as hysteresis has to be determined so that the compact ejector readjusts one time in process. Moreover, please calculate the evacuation time and the theoretical compressed-air consumption. Act on the assumption that the time required for readjustment is about 0.8 seconds.

b) Calculate the evacuation times for those degrees of evacuation that are given and enter them into the table.

Calculate the times needed for readjustment by the help of the appropriate formula.

The compressed-air consumption for the evacuation process and the readjustment should be determined as well. Calculate with the already determined evacuation times.



## Test evaluation exercise 10 a):

The essential technical indications of the compact ejector can be taken out of the table below.

Evacuation time for different vacuum levels in s/l									
Degree of evacuation [mbar]	-50	-100	-200	-300	-400	-500	-600	-700	-800
Type	mbar	mbar	mbar	mbar	mbar	mbar	mbar	mbar	mbar
SCP 10 ...									

Suction capacity at different levels of evacuation in l/min									
Degree of evacuation [mbar]	-50	-100	-200	-300	-400	-500	-600	-700	-800
Type	mbar	mbar	mbar	mbar	mbar	mbar	mbar	mbar	mbar
SCP 10 ...									

Technical data compact ejector SCP 10									
Degree of evacuation [mbar]	-50	-100	-200	-300	-400	-500	-600	-700	-800
Type	mbar	mbar	mbar	mbar	mbar	mbar	mbar	mbar	mbar
SCP 10 ...									

Chosen switch-point H1: \_\_\_\_\_ mbar

Chosen hysteresis h1: \_\_\_\_\_ mbar

### Calculation of theoretical compressed-air consumption:

Compressed-air consumption [l]			
Degree of evacuation [mbar]	1. Regulation	Readjustment	Total
Evacuation time [s]			
Compressed-air consumption [l]			





## Test evaluation exercise 10 b):

### Calculation of evacuation times

#### Calculation of evacuation time

Degree of evacuation [mbar]	-200 mbar	-300 mbar	-400 mbar	-500 mbar	-600 mbar	-700 mbar
Evacuation time for system volume in [s]						
Evacuation time for 1l in [s/l]						
Evacuation time for readjustment [s]						

### Calculation of compressed-air consumption

#### Calculation of compressed-air consumption

Degree of evacuation [mbar]	-200 mbar	-300 mbar	-400 mbar	-500 mbar	-600 mbar	-700 mbar
Compressed-air consumption evacuation in [l]						
Compressed-air consumption readjustment[l]						
Total compressed-air consumption [l]						



## Exercise 11:

### Calculation of evacuation times

#### Educational aims:

- Measuring of evacuation time of a regulated vacuum-system
- Measuring of time for readjustment of a compact ejector

#### Setting of task

The test preparation of exercise 9 is used for this exercise. However bellows suction pads **FSGA 25 NBR** are used. The functionality of the automatic air-saving of a compact ejector is discussed in tutorial III. Now the evacuation times that are necessary to reach different degrees of evacuation are to be measured. Furthermore, an approximate time should be determined that is necessary for readjustment.

At first please ensure that your system is dense. If this is the case you are able to simulate a leakage by the help of the choke valve. Open the screw of the choke valve carefully once the switch-point H1 is reached. The vacuum level of the whole system decreases as long as the lower switch-point (H1-h1) is reached and the ejector switches on again and starts to readjust.

If your system is a bit leaky the degree of evacuation will sink of its own volition. The simulation of leakage by a choke valve is not necessary.

Mind that the switch-point H1 is set on both vacuum-switches when measuring the degrees of evacuation. Elsewise a significant time measurement is impossible. The hysteresis should always be 200 mbar in this exercise.

The measurement of the evacuation time occurs as in the unregulated system in exercise 6.

To measure the time that is necessary for readjustment, please ensure that the time measuring device is adjusted to zero after measurement. There is a red button below the display that sets the display to zero automatically by pushing it. Please wait until the compact ejector has readjusted and turn the switch of the time measuring device to "valve OFF". Thus the compact ejector is switched off. Look at the display of the vacuum-switch at the gripper system and wait until the hysteresis is overspent. Turn the switch to "valve on" as soon as possible (the SCP is switched on again and readjusts!). The time measuring device measures the time that is necessary for readjustment. Repeat this measuring a few times to ensure that the value is accurate.



The circumstances described above should be clarified by following figure:

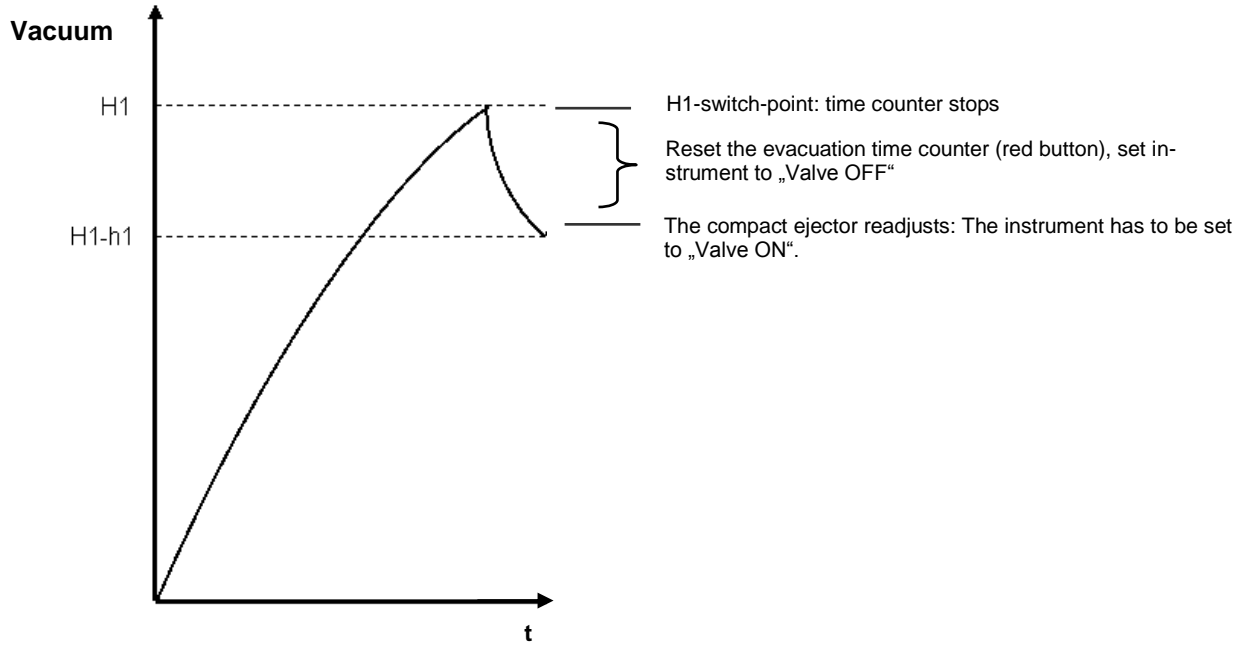

Test evaluation exercise 11		
Name:	Date:	
T III: Construction of a vacuum-system	Page 1 of 1	

## Test evaluation exercise 11: Calculation of evacuation times

Calculation of evacuation times						
Degree of evacuation [mbar]	-200 mbar	-300 mbar	-400 mbar	-500 mbar	-600 mbar	-700 mbar
Evacuation time for system volume in [s]						
Evacuation time for 1l in [s/l]						
Evacuation time for readjustment of system volume in [s]						



## Exercise 12:

### Cost analysis and comparison of SCP and SBP

#### Educational aims:

- Calculation of operation costs for compact and basic ejectors
- Cost comparison for compact and basic ejectors
- Identification of advantages of compact ejectors

#### Setting of task

The operation costs for the gripping system have been calculated in exercise 7 (tutorial II). This gripping system demonstrates an exemplary application where a press is to be assembled with stamping parts out of metal.

This exercise responds to this exemplary application. Vacuum-generators are to be chosen for this application that are ideal not only out of production-related sight but also out of economic sight. Regard the calculated values for this task exclusively. Act again on the assumption that the compact ejector has to readjust one time within an entire cycle. In addition to the automatic air-saving there is the other advantage of a compact ejector that the blow-off process can be accelerated due to a blow-off impulse. Act on the assumption that the blow-off process can be reduced to 0.2 second when using the SCP 10.

Two vacuum-generators are available:

SBP 10:	Purchase costs:	25 €
SCP 10:	Purchase costs:	480 €

Other variable unit costs (without compressed-air) amount to 0.51 € and the monthly fixed costs to 11,500 € as the calculation shows. The selling price of the completely pierced product adds up to 1.49 €. All components are expected to be distributed.

Please undertake a cost calculation on basis of present table for both kind of ejector. Determine the possible profit when using both vacuum-generators and decide in favor of a profit ideal option on basis of your results.



## Test evaluation exercise 12:

### Cost analysis and –comparison of SBP and SCP

	SBP 10	SCP 10
→ Duration of production cycle [s]		
→ Possible cycles per day		
→ Compressed-air consumption per cycle [l]		
→ Air consumption per day [l]		
→ Costs for compressed-air per day [€]		
→ Working days per year		
→ Possible pieces per year		
→ Annual fixed costs [€]		
→ Annual costs for compressed-air [€]		
→ Total costs per year [€]		
→ Price [€]		
→ Annual revenue [€]		
→ Annual profit [€]		

Test evaluation: Exercise 12		
Name:	Date:	
T III: Construction of a vacuum-system	Page 2 of 2	

With which application the use of a compact ejector make sense?

In your opinion, in which sector of industry are most of the compact ejectors used?



---

**Table of solutions**

---

**Solution for exercise 2 ..... 70**

**Solution for exercise 3 ..... 73**

**Solution for exercise 4 ..... 74**

**Solution for exercise 6 ..... 76**

**Solution for exercise 7 ..... 80**

**Solution for exercise 8 ..... 83**

**Solution for exercise 10 ..... 87**

**Solution for exercise 11 ..... 89**

**Solution for exercise 12 ..... 90**



---

## Solutions

---

All solutions for the exercises posed in this Vacuum Training-Set are arranged in this chapter. Deviations to measured values listed in this chapter can be emerge because of different environmental conditions respectively test preparations. The length and the diameter of the hoses for example, the kind of compressed-air supply or power supply of valves of ejectors exert influence on measured values. Please be always aware of the exact description of task. Besides the measured values are to be rounded up with sufficient correctness. The solutions refer to the described test evaluation with a **compressed-air supply of 5 bar** (adjustable at the pressure reduction valve).



## Solution for exercise 2:

### Theoretical calculation of holding forces for suction pad selection

#### Calculation of masses of workpieces:

m <sub>Steel plate</sub> :	<u>0.75</u> kg
m <sub>Cardboard</sub> :	<u>0.027</u> kg
m <sub>Softwood</sub> :	<u>0.320</u> kg
m <sub>Ceramic</sub> :	<u>1.117</u> kg
m <sub>Chipboard</sub> :	<u>0.419</u> kg

#### Calculation of theoretical holding forces:

(For defined basic conditions and characters of workpieces; deviations can appear by variation in these values)

Workpiece	Load case		I		II		III	
Steel plate	S:1.5	16.66 N	μ:0.5	22.29 N	μ:0.5	44.43 N		
			S:1.5		S:2			
Cardboard	S:2	0.81 N	μ:0.6	0.99 N	μ:0.6	1.68 N		
			S:2		S:2.5			
Softwood	S:2	9.44 N	μ:0.5	12.63 N	μ:0.5	23.60 N		
			S:2		S:2.5			
Ceramic	S:1.5	24.82 N	μ:0.5	33.20 N	μ:0.5	66.20 N		
			S:1.5		S:2			
Chipboard	S:2	12.40 N	μ:0.5	16.59 N	μ:0.5	31.01 N		
			S:2		S:2,5			
			S:2		S:2,5			



**Calculation of suction force  $F_s$  for each load case:**

Load case Workpiece	I	II	III
Steel plate	4.17 N	5.57 N	11.11 N
Cardboard	0.20 N	0.25 N	0.42 N
Softwood	2.36 N	3.16 N	5.90 N
Ceramic	6.21 N	8.30 N	16.55 N
Chipboard	3.10 N	4.15 N	7.75 N

**Determined suction pads by use of calculations:**

Load case Workpiece	Chosen suction pad		
	I	II	III
Steel plate (Flat suction pad)	PFYN 15	PFYN 15	PFYN 20
Cardboard (Flat suction pad)	PFYN 10	PFYN 10	PFYN 10
Softwood (Bellows suction pad)	FSG 25 or FSGA 20	FSG 18 or FSGA 20	FSG 32 or FSGA 33
Ceramic (Flat suction pad)	PFYN 15	PFYN 15	There are no suitable suction pads in the parts kit for this load case. At least a PFYN 25 is necessary (see catalogue p. 2/18)
Chipboard (Flat suction pad)	PFYN 10	PFYN 15	PFYN 15

Note: In some cases both a flat suction pad and a bellows suction pad can be used. But it has to be mentioned that a more precise positioning can be realized using a flat suction pad.

**Questions:**

**Question 1:**

Why is the holding/suction force of a flat suction pad (i. e. PFYN 20.0) higher than the holding/suction force of a bellows suction pad (i.e. FSGA 20.0) although the external diameter of the sealing lip of both suction pads is the same?

**Answer:**

The effective suction area/-diameter is used to calculate holding and suction forces. As the effective suction diameter and therefore the effective suction area of a flat suction pad is bigger than the suction area of bellows suction pads the holding force is higher according to the formula  $F = p \cdot A$  (see figure below).

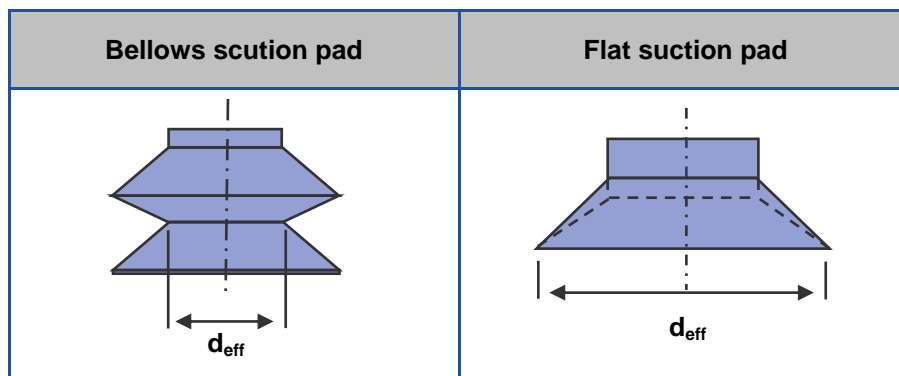



## Solution for exercise 3:

### Calculation of vacuum levels

#### Calculation of vacuum level:

Workpiece	Load case I	
	Chosen suction pad	Measured vacuum level
Steel plate	PFYN 15	-0.85 bar
Cardboard	PFYN 10	-0.80 bar
Softwood	FSG 25	-0.81 bar
Ceramic	PFYN 15	-0.83 bar
Chipboard	PFYN 10	-0.82 bar

The results show that all workpieces can be handled safely with the dedicated suction pads as a vacuum level isn't below -0.60 bar.

#### Note:

The calculation of the vacuum level has been carried out at an operation pressure of 5 bar. Little deviations are likely.



## Solution for exercise 4:

### Choice of adequate suction pads

#### Determination of ideal suction pads:

##### Measured vacuum level:

	PFYN 10.0	PFYN 15.0	PFYN 20.0	FSGA 20.0	FSGA 25.0	FSGA 33.0	FSG 18.0	FSG 25.0	FSG 32.0
Material	NBR	SI	HT1	NBR	SI	HT1	NBR	SI	HT1
Steel plate	0.85	0.85	0.85	0.85	0.85	0.85	0.85	0.85	0.85
Cardboard	0.83	0.83	0.77	0.83	0.83	0.76	0.82	0.82	0.77
Softwood	0.81	0.79	0.80	0.82	0.80	0.78	0.73	0.71	0.70
Ceramic	0.84	0.84	0.83	0.83	0.83	0.83	0.83	0.83	0.83
Chipboard	0.83	0.82	0.76	0.82	0.82	0.79	0.82	0.82	0.80

The results of measurements backs up the thesis of previous exercise that the vacuum level sinks if the workpiece is porous and the diameter of the suction bet gets bigger. A reason for this is the growth of infiltrated air that is sucked through the porous material.

The maximum attainable vacuum level is not the appropriate factor to determine the correct combination of suction pad and workpiece because not only the reached depression but also the effective suction area has to be considered when calculating suction forces. Therefore the diameter of the suction pad has to be considered in particular. Also other criteria act a part that have to be distinguished as the case arises. One example is the flexural strength of a workpiece.

##### Note:

The vacuum levels in this exercise have been determined at an operation pressure of 5 bar. Firstly the safe handling should be used as criteria for the choice of an adequate suction pad and the most cost-effective alternative is to be chosen if there arise several possibilities.

**Questions:**Question 1:

In some cases a higher vacuum level is reached with a smaller suction pad than with a bigger one. What are possible reasons therefore?

Answer:

- Diameter of suction pad

The smaller the diameter of the suction pad the higher is the achievable vacuum level because:

- The effective area of a possibly porous workpiece and therefore the amount of infiltrated air is smaller
- The suction pad's outline is smaller and therefore there is less leakage when handling structured workpieces

Question 2:

A vacuum level of at least -600 mbar is necessary for safe handling.

What kind of activities have to be undertaken that a porous workpiece with a vacuum level of about -400 mbar can be handled securely?

Answer:

- Correlation of pressure and suction area:

The suction force can be calculated by the use of following formula:

$$F = p \times A$$

F = Suction force

p = Pressure

A = Area of the suction pad

An increase in depression is technical not feasible or only with a lot of effort when handling porous workpieces. The suction force can only be increased by the area of the suction pad respectively the gripper-system. Therefore bigger suction pads can be chosen but this is not suggestive because of infiltrated air. It is beneficial to increase the number of suction pads.



## Solution for exercise 6:

### Calculation of evacuation time and theoretical compressed-air consumption

**Volume suction pad:** 4x 0.80 cm<sup>3</sup>

(see indications on data sheets and in table):

**Volume hoses: (VSL 6/4)**

4x 280 mm → V = 14.074 cm<sup>3</sup>

2x 50 mm → V = 1.2567 cm<sup>3</sup>

**Volume hoses: (VSL 8/6)**

1x 280 mm → V = 7.917 cm<sup>3</sup>

1x 1100 mm → V = 31.1 cm<sup>3</sup>

**Formula:**  $\Pi \cdot r^2 \cdot l$

**Volume storage:** 1000 cm<sup>3</sup>

**Total volume\*:** 1057.54 cm<sup>3</sup>

\*Please keep in mind that the total volume results from addition of suction pad, hoses and volume storage.



## Calculation of evacuation time:

### Basic ejector type SBP 10:

Calculation of evacuation time [s/l]									
Degree of evacuation [mbar]	-50 mbar	-100 mbar	-200 mbar	-300 mbar	-400 mbar	-500 mbar	-600 mbar	-700 mbar	-800 mbar
Evacuation time for system volume in [s]	0.109	0.224	0.473	0.756	1.081	1.464	1.931	2.527	3.356
Evacuation time for 1 liter in [s/l]	<b>0.10</b>	<b>0.21</b>	<b>0.45</b>	<b>0.71</b>	<b>1.02</b>	<b>1.38</b>	<b>1.83</b>	<b>2.39</b>	<b>3.17</b>
Evacuation time (values out of catalogue) in [s/l]	0.06	0.14	0.30	0.52	0.82	1.30	1.98	3.26	6.56
Deviation	-0.04	-0.07	-0.15	-0.19	-0.20	-0.08	0.15	0.87	3.39

### Basic ejector type SBP 15:

Calculation of evacuation time [s/l]									
Degree of evacuation [mbar]	-50 mbar	-100 mbar	-200 mbar	-300 mbar	-400 mbar	-500 mbar	-600 mbar	-700 mbar	-800 mbar
Evacuation time for system volume in [s]	0.06	0.12	0.25	0.40	0.58	0.78	1.03	1.35	1.79
Evacuation time for 1 liter in [s/l]	<b>0.06</b>	<b>0.11</b>	<b>0.24</b>	<b>0.38</b>	<b>0.55</b>	<b>0.74</b>	<b>0.98</b>	<b>1.28</b>	<b>1.70</b>
Evacuation time (values out of catalogue) in [s/l]	0.05	0.08	0.16	0.26	0.40	0.60	0.88	1.30	2.54
Deviation	-0.01	-0.03	-0.08	-0.12	-0.15	-0.14	-0.12	0.02	0.84

### Basic ejector type SBP 20:

Calculation of evacuation time [s/l]									
Degree of evacuation [mbar]	-50 mbar	-100 mbar	-200 mbar	-300 mbar	-400 mbar	-500 mbar	-600 mbar	-700 mbar	-800 mbar
Degree of evacuation [mbar]	0.03	0.07	0.14	0.23	0.33	0.44	0.58	0.76	1.02
Evacuation time for system volume in [s]	<b>0.03</b>	<b>0.06</b>	<b>0.14</b>	<b>0.22</b>	<b>0.31</b>	<b>0.42</b>	<b>0.55</b>	<b>0.72</b>	<b>0.96</b>
Evacuation time for 1 liter in [s/l]	0.03	0.05	0.09	0.16	0.24	0.34	0.49	0.80	1.74
Evacuation time (values out of catalogue) in [s/l]	0.00	-0.01	-0.05	-0.06	-0.07	-0.08	-0.06	0.08	0.78



### Diagram of evacuation time for basic ejector SBP 15

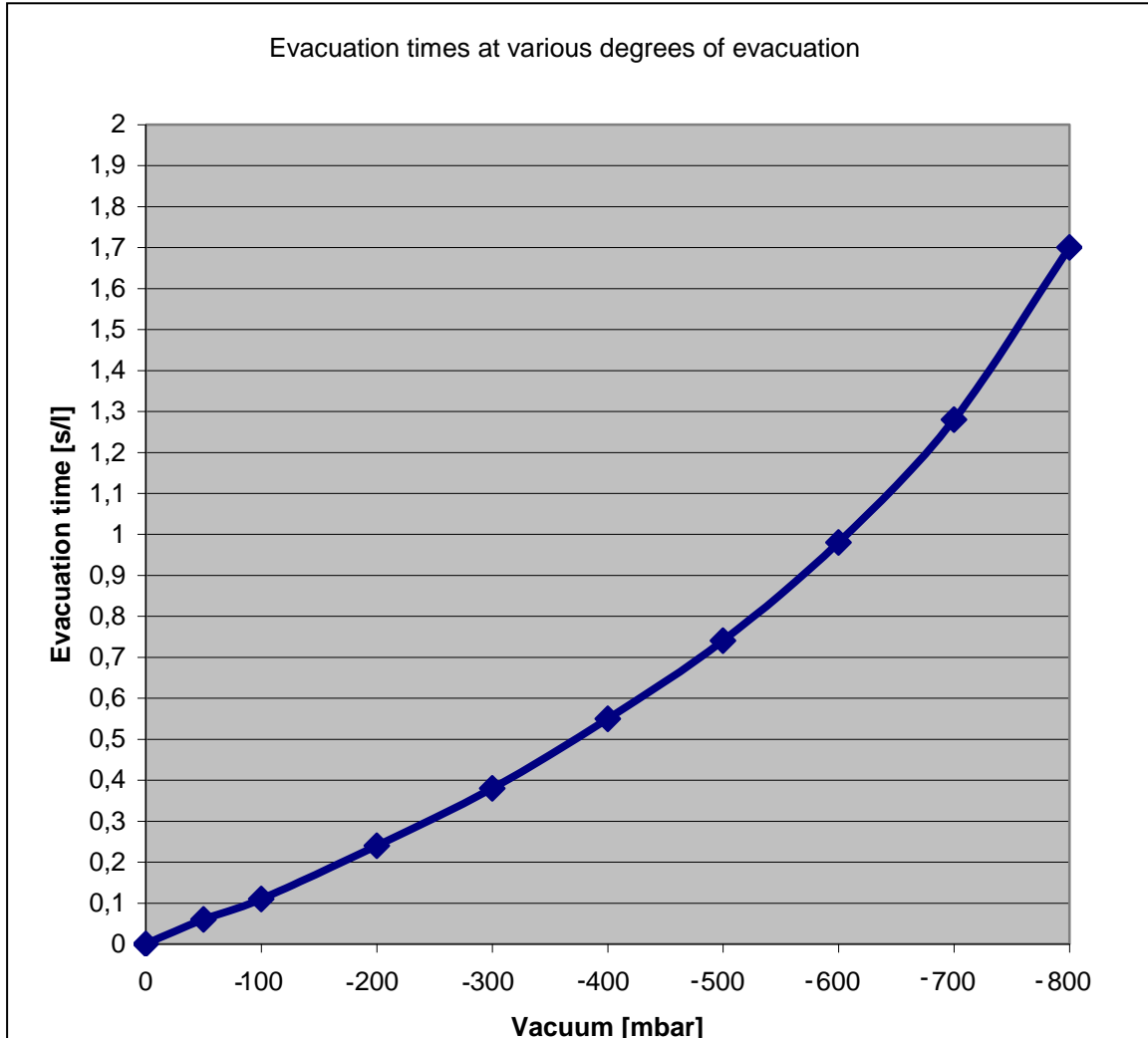



**Calculation of compressed-air consumption by the help of technical data:**

**Basic ejector type SBP 10:**

**Calculation of theoretical compressed-air consumption:**

(For the calculated evacuation time of system volume see above)

Compressed-air consumption [l]									
Degree of evacuation [mbar]	-50 mbar	-100 mbar	-200 mbar	-300 mbar	-400 mbar	-500 mbar	-600 mbar	-700 mbar	-800 mbar
PFYN 20.0 HT1	0.09	0.18	0.38	0.60	0.86	1.17	1.54	2.02	2.68

**Basic ejector type SBP 15:**

**Calculation of theoretical compressed-air consumption:**

(For the calculated evacuation time of system volume see above)

Compressed-air consumption [l]									
Degree of evacuation [mbar]	-50 mbar	-100 mbar	-200 mbar	-300 mbar	-400 mbar	-500 mbar	-600 mbar	-700 mbar	-800 mbar
PFYN 20.0 HT1	0.10	0.21	0.44	0.71	1.01	1.37	1.81	2.37	3.14

**Basic ejector type SBP 20:**

**Calculation of theoretical compressed-air consumption:**

(For the calculated evacuation time of system volume see above)

Compressed-air consumption [l]									
Degree of evacuation [mbar]	-50 mbar	-100 mbar	-200 mbar	-300 mbar	-400 mbar	-500 mbar	-600 mbar	-700 mbar	-800 mbar
PFYN 20.0 HT1	0.11	0.22	0.47	0.75	1.07	1.45	1.92	2.51	3.33



## Solution for exercise 7:

### Measuring of evacuation times

#### Basic ejector type SBP 10:

##### Measured evacuation time:

Measuring of evacuation time									
Degree of evacuation [mbar]	-50 mbar	-100 mbar	-200 mbar	-300 mbar	-400 mbar	-500 mbar	-600 mbar	-700 mbar	-800 mbar
Evacuation time for system volume in [s]	0.09	0.18	0.40	0.68	1.06	1.60	2.35	4.05	8.10
Evacuation time for 1l in [s/l] (calculation with measured values)	0.085	0.170	0.378	0.643	1.00	1.51	2.22	3.83	7.66
Evacuation time (values out of catalogue) in [s/l]	0.06	0.14	0.30	0.52	0.82	1.30	1.98	3.26	6.56
Calculated evacuation time in exercise 6	0.10	0.21	0.45	0.71	1.02	1.38	1.83	2.39	3.17

#### Basic ejector type SBP 15:

##### Measured evacuation time:

Measuring of evacuation time									
Degree of evacuation [mbar]	-50 mbar	-100 mbar	-200 mbar	-300 mbar	-400 mbar	-500 mbar	-600 mbar	-700 mbar	-800 mbar
Evacuation time for system volume in [s]	0.06	0.1	0.21	0.34	0.52	0.76	1.08	1.65	3.57
Evacuation time for 1l in [s/l] (calculation with measured values)	0.06	0.09	0.20	0.32	0.49	0.72	1.02	1.56	3.38
Evacuation time (values out of catalogue) in [s/l]	0.05	0.08	0.16	0.26	0.40	0.60	0.86	1.30	2.54
Calculated evacuation time in exercise 6	0.06	0.11	0.24	0.38	0.55	0.74	0.98	1.28	1.70



## Basic ejector type SBP 20:

### Measured evacuation time:

#### Measuring of evacuation time

Degree of evacuation [mbar]	-50 mbar	-100 mbar	-200 mbar	-300 mbar	-400 mbar	-500 mbar	-600 mbar	-700 mbar	-800 mbar
Evacuation time for system volume in [s]	0.04	0.07	0.13	0.2	0.3	0.42	0.6	0.93	1.96
Evacuation time for 1l in [s/l] (calculation with measured values)	0.04	0.07	0.12	0.19	0.28	0.40	0.57	0.88	1.85
Evacuation time (values out of catalogue) in [s/l]	0.03	0.05	0.09	0.16	0.24	0.34	0.49	0.80	1.74
Calculated evacuation time in exercise 6	0.03	0.06	0.14	0.22	0.31	0.42	0.55	0.72	0.96



**Diagram of evacuation times for basic ejectors SBP**

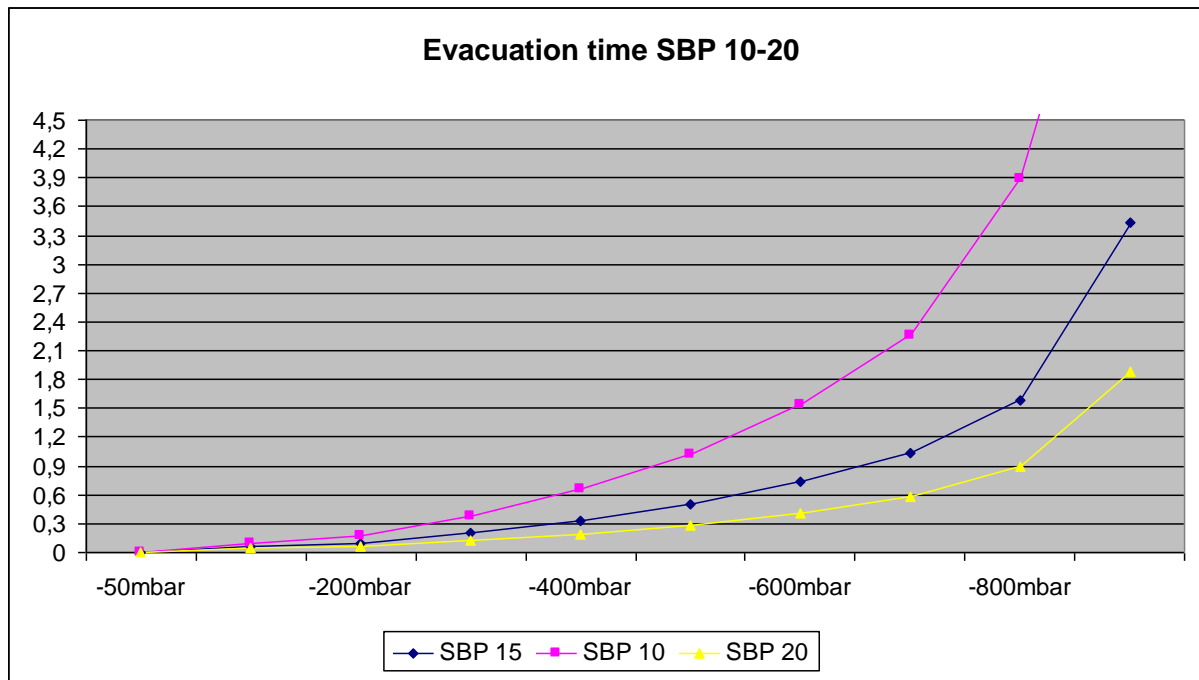

## Solution for exercise 8:

### Cost analysis

#### a) Total time of production cycle

Number	Process	Duration	Annotation
1.	Evacuation	variable	Up to -600 mbar
2.	Holding	1 s (If the difference of evacuation time from -600 mbar to -700 mbar is > 1 s the evacuation time is used), because there is the evacuation process during handling process	Up to -700 mbar
3.	Transportation	6 s	
4.	Sagging	1 s	
5.	Blow-off	2 s	
6.	Reverse	2 s	Back to the initial position: Gripper system is directly on the next stamping part

#### Duration of total process using the example of SBP 10:

2 shifts with 8 hours each → 16 hours → 960 min → 57,600 s

#### Duration of one cycle:

Evacuation (up to -600 mbar)	2.35 s
Holding vertical (-600 mbar up to -700 mbar)	1.7 s
Transportation	6 s
Sagging	1 s
Depositing	2 s
Reverse to initial position	2 s

From this follows:

$$(2.35 + 1.7 + 6 + 1 + 2 + 2)s = 15.05 \text{ s} \rightarrow \frac{57.600s}{15,05 \frac{s}{\text{cycle}}} = 3.827 \text{ cycles per day}$$



## b) Total compressed-air consumption and theoretical costs using the example of SBP 10

### Duration of air consumption per cycle:

Evacuation 2.35 s

Holding 1.7 s

Transportation 6 s

Sagging 1 s

→  $(2.35 + 1.7 + 6 + 1)s = 11.05 s$  (Time when compressed-air is used by the ejector)

### Total duration of air consumption on a workday:

→  $3,827 \text{ cycles} \cdot 11.05s = 42,288.35s \rightarrow \frac{42,288.35s}{60s} \approx 704.81 \text{ min}$

### Costs for compressed-air on a working day: (Air consumption suction 48 l/min)

$$704.81 \text{ min} \cdot 48 \frac{l}{\text{min}} = 33,830.88l$$

$$33830.88l \div 1000 = 33.83m^3$$

$$33.83m^3 \cdot 0.03\text{€} = 1.015\text{€}$$

**For SBP 15:** 2.10 € per working day

**For SBP 20:** 3.87 € per working day

### SBP 10:

Operation costs								
Degree of evacuation [mbar]	-50 mbar	-100 mbar	-200 mbar	-300 mbar	-400 mbar	-500 mbar	-600 mbar	-700 mbar
Cycle time in [s]	X							15.05
Possible cycles per day								3827
Air consumption per cycle in [l]								8.84
Air consumption per day in [l]								33830.88
Operation costs per day in [€]								1.015



**SBP 15**

Operation costs								
Degree of evacuation [mbar]	-50 mbar	-100 mbar	-200 mbar	-300 mbar	-400 mbar	-500 mbar	-600 mbar	-700 mbar
Cycle time in [s]								13.08
Possible cycles per day								4404
Air consumption per cycle in [l]								15.89
Air consumption per day in [l]								69.979
Operation costs per day in [€]								2.10

**SBP 20**

Operation costs								
Degree of evacuation [mbar]	-50 mbar	-100 mbar	-200 mbar	-300 mbar	-400 mbar	-500 mbar	-600 mbar	-700 mbar
Cycle time in [s]								12.6
Possible cycles per day								4571
Air consumption per cycle in [l]								28.4
Air consumption per day in [l]								129.069.8
Operation costs per day in [€]								3.87

No transportation is possible at degrees of evacuation of -50 mbar up to -500 mbar. From -600 mbar depression the robot is able to handle the workpiece vertically.

Once a degree of evacuation of -700 mbar is reached the workpiece can also be handled horizontally.

**c) Costs at low degrees of evacuation:**

Example for degree of evacuation of -50 mbar:

$$10,800 \frac{\text{cycles}}{\text{day}} \cdot 0.09 \frac{\text{s}}{\text{cycle}} = 972 \frac{\text{s}}{\text{day}} = 0.27 \text{ hours per day}$$

$$0.27 \frac{\text{h}}{\text{day}} \cdot 2.9 \frac{\text{m}^3}{\text{h}} \cdot 3 \frac{\text{ct}}{\text{m}^3} = 2.35 \frac{\text{ct}}{\text{day}}$$

**Basic ejector SBP 10:**

Costs									
Degree of evacuation [mbar]	-50 mbar	-100 mbar	-200 mbar	-300 mbar	-400 mbar	-500 mbar	-600 mbar	-700 mbar	-800 mbar
	2.35ct	4.70ct	10.44ct	17.75ct	27.67ct	41.76ct	61.34ct	105.71ct	211.41ct

**Basic ejector SBP 15:**

Costs									
Degree of evacuation [mbar]	-50 mbar	-100 mbar	-200 mbar	-300 mbar	-400 mbar	-500 mbar	-600 mbar	-700 mbar	-800 mbar
	3.40ct	5.67ct	11.91ct	19.28ct	29.48ct	43.09ct	61.24ct	93.56ct	202.42ct

**Basic ejector SBP 20:**

Costs									
Degree of evacuation [mbar]	-50 mbar	-100 mbar	-200 mbar	-300 mbar	-400 mbar	-500 mbar	-600 mbar	-700 mbar	-800 mbar
	4.25ct	7.43ct	13.81ct	21.24ct	31.86ct	44.60ct	63.72ct	98.77ct	208.15ct

d) Question about diagram:

Because a lower theoretical holding force is necessary for handling vertically (load case I) than for horizontal handling of workpieces (load case II). (See tutorial I exercise 2)



## Solution for exercise 10 a):

### Calculation of theoretical compressed-air consumption

**Switch-point H1:** A handling of workpiece is possible from a value of -600 mbar.

**Hysteresis h1:** Hysteresis of 100 mbar

The hysteresis **h1** can reach a value between -150 mbar and -100 mbar.

#### Calculation of evacuation time:

Total volume of system: 1.0575 l (working-out see exercise 6)

$$1.0575 \text{ l} = 0.0010575 \text{ m}^3$$

$$t_{EV} = \frac{V \cdot \ln\left(\frac{P_a}{P_e}\right) \cdot 1.3}{V_{Ejector}} \rightarrow t_{EV} = \frac{0.0010575 \cdot \ln\left(\frac{1013}{413}\right) \cdot 1.3}{2.2} \cdot 3600 = 2.018 \text{ s}$$

#### Calculation of theoretical compressed-air consumption during the first evacuation:

$$2.018 \text{ s} \cdot \frac{53 \frac{\text{l}}{\text{min}}}{60 \text{ s}} = 1.783 \text{ l}$$

#### Calculation of theoretical compressed-air consumption during readjustment:

$$0.8 \text{ s} \cdot \frac{53 \frac{\text{l}}{\text{min}}}{60 \text{ s}} = 0.707 \text{ l}$$

Compressed-air consumption [l]			
Degree of evacuation [mbar]	1. adjustment	readjustment	total
Evacuation time [s]	2.018	0.8	2.818
Compressed-air consumption [l]	1.783	0.707	2.49



## Solution for exercise 10 b):

### Calculation of evacuation times and compressed-air consumption

These values can deviate from your measured values depending on the impermeability of the system.

Calculation of evacuation time						
Degree of evacuation [mbar]	-200 mbar	-300 mbar	-400 mbar	-500 mbar	-600 mbar	-700 mbar
Evacuation time for system volume in [s]	0.495	0.790	1.130	1.531	2.018	2.642
Evacuation time for 1l in [s/l]	0.47	0.75	1.07	1.45	1.91	2.50
Evacuation time for readjustment [s]	0.28	0.32	0.38	0.46	0.59	0.82

Calculation of compressed-air consumption						
Degree of evacuation [mbar]	-200 mbar	-300 mbar	-400 mbar	-500 mbar	-600 mbar	-700 mbar
Compressed-air consumption evacuation in [l]	0.43	0.69	0.98	1.33	1.75	2.30
Compressed-air consumption readjustment [l]	0.26	0.30	0.35	0.43	0.55	0.76
Total compressed-air consumption [l]	0.69	0.99	1.33	1.76	2.30	3.06

## Solution for exercise 11:

### Calculation of evacuation times

#### Measuring of times for evacuation and readjustment:

Calculation of evacuation time						
Degree of evacuation [mbar]	-250 mbar	-300 mbar	-400 mbar	-500 mbar	-600 mbar	-700 mbar
Evacuation time system volume in [s]	0.55	0.,83	1.33	1.96	2.95	4.67
Evacuation time for 1l in [s/l]	0.52	0.78	1.26	1.85	2.79	4.42
Evacuation time readjustment for system volume in [s]	0.2	0.5	0.7	1.0	1.2	2.6



## Solution for exercise 12:

### Cost analysis and comparison of SCP 10 and SBP 10

#### Calculation using the example of SCP 10

##### Possible cycles per day:

2 shifts per day with 8 hours each → 16 hours → 960 min → 57,600 s

##### Duration of a cycle:

Evacuation (up to -600 mbar)	1.99 s
Holding (-600 mbar up to -700 mbar)	1 s
Transportation	6 s
Sagging	1 s
Blow-off	0.2 s
Reverse to initial position	2 s

From this it follows:

$$(2.35+1+6+1+0.2+2)\text{s} = \mathbf{12.19\text{ s}} \rightarrow \frac{57600\text{s}}{12.19 \frac{\text{s}}{\text{cycle}}} = 4725 \text{ cycles per day}$$

##### Duration air consumption per cycle:

Evacuation (up to -700 mbar)	2.6 s
Readjustment	0.8 s
Blow-off	0.2 s

From this it follows:

$$(2.35+1+6+1+0.2+2)\text{ s} = \mathbf{3.6\text{ s}}$$

##### Air consumption per cycle:

$$\frac{53 \frac{\text{l}}{\text{min}} \cdot 3.6\text{s}}{60} = 3.18\text{l}$$

**Air consumption per day:** 4,725 cycles per day \* 3.18 l = 15,025.5 l

$$252 \cdot 4725 = 1,190,700 \text{ possible cycles per year}$$

**Costs compressed-air per day:**

$$\frac{3.18l \cdot 4725}{1000} \cdot 3 \frac{ct}{m^3} = 45 ct$$

**Possible units per year:**

$$252 days \cdot 4725 cycles \text{ per day} = 1,190,700$$

**Annual fixed costs:**

$$11,500€ \cdot 12 + 480€ = 138,480€$$

**Annual variable costs:**

$$0.51€ \cdot 1,190,700 = 607,257€$$

**Annual costs for compressed-air:**

$$\frac{3.18l \cdot 1,190,700}{1000} \cdot 3 \frac{ct}{m^3} = 113.59€$$

**Total costs per year:**

$$(138,480 + 607,257 + 113.59) € = 745,850.59 €$$

**Total profit:**

$$1.49€ \cdot 1,190,700 = 1,774,143.00€$$

**Total benefit (using SCP10):**

$$1,774,143.00€ - 745,850.59€ = 1,028,292.41 €$$



	<b>SBP 10</b>	<b>SCP 10</b>
➔ Duration of production cycle [s]	15.05	12.19
➔ Possible cycles per day	3,827	4,725
➔ Compressed-air consumption per cycle [l]	8.84	3.18
➔ Air consumption per day [l]	33,830.68	15,025.5
➔ Costs for compressed-air per day [€]	1.01	0.45
➔ Working days per year	252	252
➔ Possible pieces per year	964,404	1,190,700
➔ Annual fixed costs [€]	138,025 €	138,480 €
➔ Annual costs for compressed-air [€]	255.76 €	113.59 €
➔ Total costs per year [€]	630,126.80 €	745,850.59 €
➔ Price [€]	1.49 €	1.49 €
➔ Annual revenue [€]	1,436,961.96 €	1,774,143.00 €
➔ Annual profit [€]	<b>806,835.16 €</b>	<b>1,028,292.41 €</b>

**Excess profit SPC: 221,457.25 € per year.**



Solution: Cost analysis and comparison of SCP 10 and SBP 10 (exercise 12)		
Name:	Date:	
T III: Construction of a vacuum-system	Page 4 of 4	

**With which application the use of a compact ejector make sense?**

-The application of compact ejectors is only suggestive if the workpieces are airtight because only in this case the automatic air-saving function can operate. As the vacuum decreases very fast when porous workpieces are handled and therefore the compact ejector has to switch on again immediately the cost advantage is considerably low.

**In your opinion, in which sector of industry are most of the compact ejectors used?**

-Compact ejectors are often used for handling of metals and plastics. A possible sector or industry can be the automotive industry for example.



---

**List of appendices**

---

**Content of CD-ROM..... XII**

**Product data sheets ..... XIII**

Flat suction pad (round) PFYN ..... XIII

Bellows suction pad (round, 1.5 folds) FSGA..... XV

Bellows suction pad (round, 2.5 folds) FSG ..... XVII

**Operating instructions basic ejector SLP/SBP ..... XIX**

**Operating instructions ejector SCP / SMP ..... XXI**

**Operation instructions vacuum switch ..... XXXVI**

**Brief Operating Instructions Vacuum Switch ..... XL**

**Operation instructions evacuation time counter ..... XLII**

## Content of CD-ROM

The CD-Rom contains additional media. It comprises both exercises of the tutorials and solutions in terms of PDF files.

Further topics of the CD-ROM are:

- Operation manual
- Data sheets
- VacuCalculator
- Application examples out of practice
- Schmalz catalogue
- Exercises

**Operation manual:** The operation manual for several components such as ejectors or switches should assist by using and implementing these devices and should be regarded previously.

**Data sheets:** The data sheets contain technical data for the suction pads available. They are available as PDF-files.

**VacuCalculator:** The VacuCalculator is a software-tool to convert parameters and to configure vacuum-systems simple and fast.

**Application examples out of practice:** The application examples show possible operational areas of vacuum-technology and successful implemented concepts in industry.

**Schmalz catalogue:** You get the main catalogue of the J. Schmalz GmbH. It contains both components that are used in the tutorials and the entire product program of the vacuum components.

**Exercises** The exercises are available electronically.

## Product data sheets

### Flat suction pad (round) PFYN

#### Circuit symbol

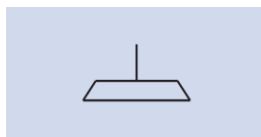

#### Construction

The flat suction pad PFYN is a robust and imperishable suction pad with single sealing lip. The suction pads' components are the suction pad PFG and the nipple for connection.

#### Application

Due to ideal design and light volume the flat suction pad is suitable for handling of even and slightly curved workpieces with plain or lightly rough surface. Besides it is possible to have high suction forces with small dimensions. This enables fast cycle times of workpieces in turn.

### Flat suction pad (round) PFYN 10.0

#### Illustration



#### Technical drawing

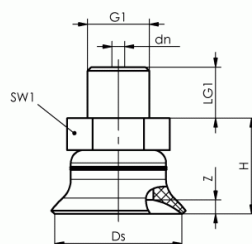

#### Technical data

Material	Perbunan NBR 55 ± 5
Suction force [N]	4.0
Volume [cm <sup>3</sup> ]	0.07
Recommend inner diameter of hose [mm]	2.0
Min. workpiece radius [mm] (convex)	13

**Flat suction pad (round) PFYN 15.0**

**Illustration**



**Technical drawing**

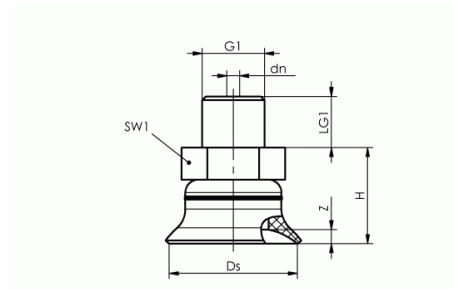

**Technical data**

Material	Silicone SI 55±5
Suction force [N]	9.0
Volume [cm <sup>3</sup> ]	0.4
Recommend inner diameter of hose [mm]	4.0
Min. workpiece radius [mm] (convex)	13

**Flat suction pad (round) PFYN 20.0**

**Illustration**



**Technical drawing**

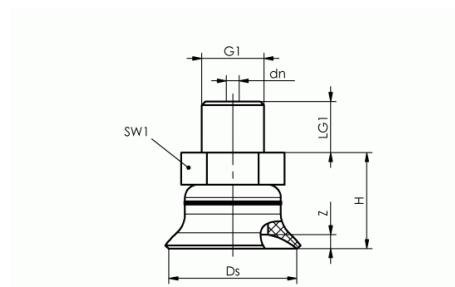

**Technical data**

Material	High temp. material HT1 60±5
Suction force [N]	15.5
Volume [cm <sup>3</sup> ]	0.8
Recommend inner diameter of hose [mm]	4.0
Min. workpiece radius [mm] (convex)	20.0

## Bellows suction pad (round, 1.5 folds) FSGA

### Circuit symbol

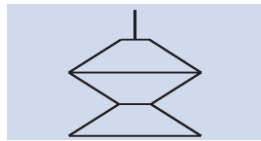

### Construction

The bellows suction pad FSGA is a robust and imperishable suction pad with soft and tapered sealing lip. It consists of the suction pad FGA with 1.5 folds and the connection nipple.

### Application

The bellows suction pad is suitable for handling extremely sensitive workpieces. Due to folds it is able to adapt to curved surfaces (ideal adaptation to free-forming surfaces) or unevenness of workpiece. In addition ideal absorbability can be achieved. Inner support surfaces avoid tapering.

### Bellows suction pad (round, 1.5 folds)

### FSGA 20.0

### Illustration



### Technical drawing

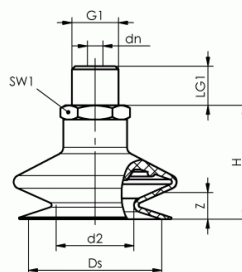

### Technical data

Material	Perbunan NBR 55±5
Suction force [N]	4.7
Tear-off force [N]	10.7
Volume [cm <sup>3</sup> ]	1.15
Recommended inner diameter d [mm]	4.0
Min. workpiece radius [mm] (convex)	30.0

**Bellows suction pad**  
**(round, 1.5 folds)**

Illustration



Technical data

**FSGA 25.0**

Technical drawing

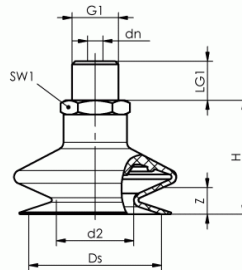

Material	Silicone SI 55±5
Suction force [N]	5.3
Tear-off force [N]	17.3
Volume [cm <sup>3</sup> ]	3.15
Recommended inner diameter d [mm]	4.0
Min. workpiece radius [mm] (convex)	20.0

**Bellows suction pad**  
**(round, 1.5 folds)**

Illustration



Technical data

**FSGA 33.0**

Technical drawing

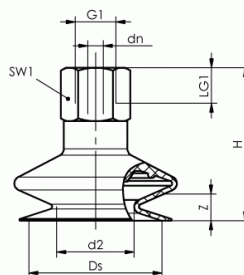

Material	High temp. material HT1 60±5
Suction force [N]	13.6
Tear-off force [N]	39.6
Volume [cm <sup>3</sup> ]	4.75
Recommended inner diameter d [mm]	6.0
Min. workpiece radius [mm] (convex)	40.0

## Bellows suction pad (round, 2.5 folds) FSG

### Circuit symbol

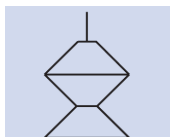

### Construction

The bellows suction pad FSG with 2.5 folds consists of a suction pad FG and the connection nipple.

### Application

It is very suitable for handling of extremely sensitive workpieces (ideal absorbability due to folds, inner support surfaces avoid tapering) or extremely uneven or curved workpieces such as tubes (ideal adaptation to free-forming surfaces due to 2.5 folds).

### Bellows suction pad (round, 2.5 folds)

### FSG 18

### Illustration



### Technical drawing

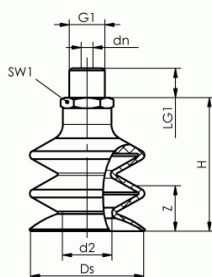

### Technical data

Material	Perbunan NBR 55 ± 5
Suction force [N]	2.3
Tear-off force [N]	8.5
Volume [cm <sup>3</sup> ]	1.35
Recommended inner diameter d [mm]	4.0
Min. workpiece radius [mm] (convex)	20.0



**Bellows suction pad**  
**(round, 2.5 folds)**

Illustration



Technical data

**FSG 25**

Technical drawing

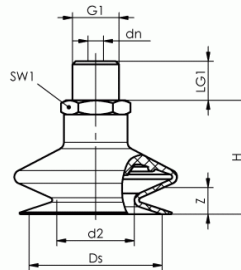

Material	Silicone SI 55±5
Suction force [N]	4.5
Tear-off force [N]	19
Volume [cm <sup>3</sup> ]	5,4
Recommended inner diameter d [mm]	4.0
Min. workpiece radius [mm] (convex)	30.0

**Bellows suction pad**  
**(round, 2.5 folds)**

Illustration



Technical data

**FSG 32**

Technical drawing

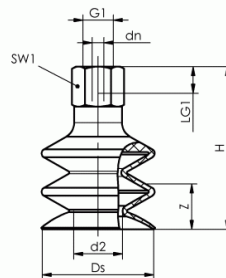

Material	High temp. material HT1 60±5
Suction force [N]	12.0
Tear-off force [N]	36.9
Volume [cm <sup>3</sup> ]	10.0
Recommended inner diameter d [mm]	6.0
Min. workpiece radius [mm] (convex)	35.0

# Operating instructions basic ejector SLP/SBP

Bedienungsanleitung  
Ejektor SLP/SBP

DE

Operating instructions  
Ejector SLP/SBP

EN

Instructions de service pour l'  
Éjecteur SLP/SBP

FR

## Sicherheit

- Diese Bedienungsanleitung enthält wichtige Informationen zum Umgang mit dem Vakuum-Erzeuger. Bitte lesen Sie die Bedienungsanleitung sorgfältig durch und bewahren Sie diese für spätere Zwecke auf.
- Unter Druckluft stehende Geräte können Personen- und Sachschäden verursachen.
- Anschlüsse unbedingt richtig anschließen und niemals verschließen – Berstgefahr!
- Schalten Sie vor Installations- und Wartungsarbeiten die Druckluftversorgung aus.
- Das erzeugte Vakuum sollte überwacht werden um evtl. Störungen der Vakuum-Erzeugung zu erkennen
- Bei Betrieb ohne Schalldämpfer ist unbedingt ein Gehörschutz zu tragen
- Niemals in den Luftstrom sehen

## Bestimmungsgemäße Verwendung

Das Gerät dient zur Vakuum-Erzeugung das heißt zum Evakuieren von z. B. Sauggreifern zwecks Festhalten von Nutzlasten oder zum Evakuieren anderer Volumina. Als zu evakuierendes Medium sind Luft oder andere neutrale Gase gemäß ISO 8573-1 zugelassen. Das Gerät dient nicht zum Transport (Durchsaugen) von Flüssigkeiten, Gasen und oder Granulaten.

## Installation

- Bei starken Verschmutzungen ist ein entsprechender Filter zu verwenden
- Anschluss laut Aufdruck Ejektor Druckanschluss P (1) / Vakuumanschluss V (2) Abluftanschluss / Schalldämpfer R (3) nicht verschließen
- Unbedingt maximales Anzugsmoment bei der Befestigung mit M4-Schrauben von 0,7 Nm beachten!
- Optionale Cliquelleiste entsprechend Anzahl Ejektoren ablängen

## Safety

- These operating instructions contain important information on using the vacuum generator. Please read the operating instructions thoroughly and keep them for later reference.
- Devices with compressed air can cause harm to people and damage property.
- Ensure that you make all connections correctly and never close them off – danger of bursting!
- Before installation and maintenance work, switch the supply of compressed air off.
- The vacuum created should be monitored to detect possible faults in vacuum generation.
- If run without a sound absorber, ear protection must be worn.
- Never look into the air flow.

## Intended use

The device is designed to generate a vacuum, i.e. to evacuate suction pads for holding payloads or to evacuate other volumes. Air or other neutral gases in accordance with ISO 8573-1 are approved as media for evacuation.

The device is not suitable for transporting (through-suction) of liquids, gases and/or granulates.

## Installation

- An appropriate filter must be used for heavy soiling.
- Connection in accordance with the label on the ejector Printing connection P (1) / vacuum connection V (2) Do not close off exhaust air connection / sound absorber R (3)
- Observe the maximum starting torque of 0.7 Nm when fastening using M4 screws!
- Cut the optional clip strip in accordance with the number of ejectors

## Sécurité

- Ces instructions de service contiennent des informations importantes concernant l'utilisation du générateur de vide. Veuillez les lire attentivement et les conserver en lieu sûr pour consultation ultérieure.
- Les appareils sous air comprimé sont susceptibles d'entraîner des dommages corporels et matériels.
- Contrôlez impérativement les raccords et veillez à ce qu'aucune conduite ne soit obstruée – risque d'éclatement.
- Avant de commencer les travaux d'installation ou d'entretien, désactivez l'alimentation d'air comprimé
- Le vide généré doit être contrôlé afin de détecter des pannes éventuelles de la génération du vide.
- Portez impérativement une protection auditive lorsque l'appareil est utilisé sans silencieux.
- Ne regardez en aucun cas dans le courant d'air.

## Utilisation conforme

L'appareil sert à générer le vide, c.-à-d. à évacuer l'air de ventouses afin de tenir des charges ou à l'évacuer d'autres volumes. Le moyen autorisé pour l'évacuation est l'air ou des gaz neutres conformément à la directive ISO 8573-1.

L'appareil ne sert pas au transport (à pomper) des liquides, des gaz ou des granulés.

## Installation

- Un filtre adapté doit être installé en cas de fort encrassement.
- Raccordez conformément à l'étiquette de l'éjecteur Raccord de la pression P (1) / raccord du vide V (2) Raccord de l'air d'échappement / ne pas obstruer le silencieux R (3)
- Respectez impérativement le couple de serrage maximal lors de la fixation à l'aide de vis M4 de 0,7 Nm!
- Suspendez la baguette à agrafes en option selon le nombre d'éjecteurs

## Technische Daten / Specifications / Données techniques

Typ / Model / Type	SLP 05	SLP 07	SBP 05	SBP 07	SBP 10	SBP 15	SBP 20	SBP 25
Düse / Nozzle / Buse	0.5	0.7	0.5	0.7	1.0	1.5	2.0	2.5
Max. Vakuum / Max. vacuum / Vide max. [mbar]	830	850	840	850	850	850	850	850
Saugvermögen / Suction capacity / Capacité d'aspiration [l/min]	8	15	7	16	37	70	124	215
Luftverbrauch / Air consumption / Consommation d'air [l/min]	13	25	13	25	48	118	186	311
Betriebsdruck / Operating pressure / Pression de service [bar]	3-6							
Opt. Betriebsdruck / Opt. operating pressure / Pression de service optimale [bar]	4.5							
Gewicht / Weight / Poids [g]	5	5	8	8	22	22		
Einbaulage / Installation position / Position d'installation	Beliebig / Any / Indifférente							
Empfohlener Schlauchinnendurchmesser P/V / Recommended internal hose diameter P/V / Diamètre de tuyau intérieur recommandé P/V [mm] <sup>1</sup>	2/2	2/2	2/2	2/2	4/6	4/6	6/8	6/8
Max. Anzugsdrehmoment / Max. starting torque / Couple de serrage max. [Nm]	0,7							
Temperaturbereich / Temperature range / Plage de température [°C]	0...+50							
Betriebsmedium / Operating medium / Moyen de fonctionnement	Druckluft, ungeölt oder geölt nach ISO 8573-1:2001, Klasse 7 <sup>2</sup> -4 <sup>3</sup> / Compressed air, oiled or non-oiled in accordance with ISO 8573-1:2001, class 7 <sup>2</sup> -4 <sup>3</sup> / Air comprimé huilé ou non conf. à ISO 8573-1:2001, classe 7 <sup>2</sup> -4 <sup>3</sup>							
Verwendete Werkstoffe / Materials used / Matériaux utilisés	PA6 GF30, Aluminium, Messing, POM, NBR, PE / PA6 GF30, aluminium, brass, POM, NBR, PE / PA6 GF30, aluminium, laiton, POM, NBR, PE							
Ejektoren pro Cliquelleiste / Ejectors per clip strip / Ejecteurs par baguette à agrafes	-		11			7		5

<sup>1</sup> Die angegebenen Werte beziehen sich auf eine Schlauchlänge von max. 2m. Bei größeren Leitungslängen jeweils den nächst höheren Schlauchdurchmesser wählen  
<sup>2</sup> Empfehlung Klasse 6 (5µm)  
<sup>3</sup> Max. 30 mg/m<sup>3</sup> (2 Tropfen) bei einem Nenndurchlass von q<sub>v</sub>=1000 l/min

<sup>1</sup> The values specified refer to a hose length of max. 2m. Select the next largest hose diameter for longer hose lengths.  
<sup>2</sup> Recommendation for class 6 (5µm)  
<sup>3</sup> Max. 30 mg/m<sup>3</sup> (2 drops) for a nominal throughput of q<sub>v</sub>=1000 l/min

<sup>1</sup> Les valeurs indiquées se basent sur une longueur de tuyau maximale de 2 m Pour des tuyaux de plus grandes longueurs, utilisez le type supérieur correspondant  
<sup>2</sup> Recommandation classe 6 (5µm)  
<sup>3</sup> Au maximum 30 mg/m<sup>3</sup> (2 gouttes) pour un débit nominal de q<sub>v</sub>=1000 l/min

## Zubehör / Accessories / Accessoires

Typ / Model / Type	SBP 05/07...	SBP 10/15...	SBP 20/25...
Schalldämpfer / Sound absorber / Silencieux	10.02.01.00539	10.02.01.00540	10.02.01.00719
Cliquelleiste / Clip strip / Baguette à agrafes		10.02.01.00511	

## Abmessungen / Dimensions / Dimensions [mm]

SLP...	SBP...S... Schlauchanschluss / Hose connection / Raccord de tuyau										SBP...G... Gewindeanschluss / Threaded connection / Raccord fileté					Cliquelleiste / Clip strip / Baguette à agrafes						
Type	B	D	D1	d1	d2	d3	G1	G2	G3	H	H1	H2	L	L1	L2	L3	L4	L5	SW1	SW2	X1	Y1
SLP 05/07...	-	10	-	4	4	-	-	-	-	-	-	-	57	-	-	-	-	-	-	-	-	-
SBP 05/07...S...	10	-	9	4	4	4,2	-	-	-	28	12	5,2	45	69	18,2	-	12,5	32,5	-	-	-	-
SBP 05/07...G...	10	-	9	-	-	4,2	M5	M5	M5	31	23	5,2	45	69	18,2	5	12,5	32,5	8	8	-	-
SBP 10/15...S...	15	-	13,5	6	8	4,2	-	-	-	40	14	5,2	51,5	91,5	22	-	12,5	32,5	-	-	-	-
SBP 10/15...G...	15	-	13,5	-	-	4,2	G1/8"	G1/8"	G1/8"	42	14	5,2	51,5	91,5	22	10	12,5	32,5	14	14	-	-
SBP 20/25...S...	20	-	-	8	10	4,2	-	-	-	-	-	5,2	-	-	-	-	12,5	32,5	-	-	-	-
SBP 20/25...G...	20	-	-	-	-	4,2	G1/4"	G3/8"	G3/8"	-	-	5,2	-	-	-	-	12,5	32,5	-	-	-	-
Leiste / Leiste / Baguette	45	-	-	-	-	2,1	-	-	-	-	-	-	111,1	-	-	-	-	-	-	-	10,1	30

Technische Änderungen und Druckfehler vorbehalten

We reserve the right to make technical changes. No responsibility is taken for printing or other types of errors.

Sous réserve de modifications techniques ou de fautes d'impression!

# Instrucciones de manejo del Ejector SLP/SBP

ES

## Seguridad

- Estas instrucciones de manejo contienen importantes informaciones relativas al trabajo con el generador de vacío. Léase estas instrucciones cuidadosamente y guárdelas para su uso posterior.
- Los aparatos con aire comprimido pueden causar daños personales y materiales.
- Conecte sin falta correctamente las conexiones y no las cierre nunca – ¡peligro de reventón!
- Desconecte la alimentación de aire comprimido antes de efectuar trabajos de instalación y mantenimiento.
- El vacío generado deberá vigilarse para detectar posibles fallos en la generación de vacío.
- En caso del funcionamiento sin silenciador se debe llevar imprescindible protección auditiva.
- No mire nunca hacia la corriente de aire.

## Uso apropiado

El aparato sirve para la generación de vacío, es decir, para evacuar, por ejemplo, ventosas con el objeto de que puedan sujetar cargas útiles o para evacuar otros volúmenes. Los medios a evacuar permitidos en conformidad con ISO 8573-1 son aire u otros gases neutros.

El aparato no sirve para transportar (mediante aspiración) líquidos, gases o granulados.

## Instalación

- En caso de mucha suciedad hay que utilizar un filtro correspondiente.
- Conexión conforme a impresión en el ejector  
Conexión de presión P (1) / conexión de vacío V (2)  
No cerrar la conexión de aire de salida / silenciador R (3)
- ¡Respete sin falta el par de apriete máximo de 0,7 Nm en caso de usar tornillos M4 para la fijación!
- Corte a medida la barra de clips opcional en función del número de ejectores.

# Istruzioni per l'uso Eiettore SLP/SBP

## Seguridad

- Ueste istruzioni per l'uso contengono informazioni importanti per l'utilizzo del produttore di vuoto. Leggere attentamente le presenti istruzioni e conservarle per un utilizzo futuro.
- Gli apparecchi ad aria compressa possono causare danni a persone e cose.
- Collegare correttamente gli attacchi e non chiuderli mai – pericolo di scoppio!
- Prima di effettuare i lavori di installazione e manutenzione, disinserire la produzione di vuoto.
- Il vuoto prodotto dovrebbe essere sorvegliato per riconoscere eventuali disturbi della produzione di vuoto
- In caso di esercizio senza silenziatore, indossare le apposite cuffie di protezione
- Non guardare mai il flusso d'aria

## Utilizzo conforme alle istruzioni

L'apparecchio serve per la produzione di vuoto, ovvero per l'evacuazione ad es. di ventose al fine di tenere fermi carichi di servizio o per l'evacuazione di altri volumi. Come mezzo di evacuazione sono ammessi l'aria o altri gas neutri secondo ISO 8573-1.

L'apparecchio non serve per il trasporto (aspirazione) di liquidi, gas e/o granulati.

## Installazione

- In presenza di forte sporco, utilizzare l'apposito filtro.
- Non chiudere l'attacco secondo la scritta eiettore attacco a pressione P (1) / attacco vuoto V (2) raccordo di scarico / silenziatore R (3)
- Osservare la coppia di serraggio massima di 0,7 Nm per il fissaggio con viti M4!
- Regolare la lunghezza della barra a clip opzionale in base al numero degli eiettori

IT

# Handleiding Ejector SLP/SBP

NL

## Veiligheid

- Deze handleiding bevat belangrijke informatie voor het gebruik van de vacuümgenerator. Lees de handleiding zorgvuldig door en bewaar deze voor later.
- Toestellen die onder druk staan kunnen letselschade en materiële schade veroorzaken.
- Aansluitingen goed aansluiten en nooit afsluiten – gevaar van barsten!
- Schakel voor installatie- en onderhoudswerkzaamheden de persluchttoevoer uit.
- Het opgebouwde vacuüm moet bewaakt worden om evt. storingen in de vacuümpomp te herkennen
- Als er geen geluïdemper wordt gebruikt, dient er altijd gehoorbescherming gedragen te worden
- Kijk nooit in de luchtstroom

## Reglementair gebruik

Het toestel is bestemd voor vacuümpompwerking, d.w.z. voor het evacueren van bijv. vacuümgrijpers met als doel het vasthouden van lasten of het evacueren van andere elementen. Het apparaat mag worden toegepast om lucht en andere neutrale gasen conform ISO 8573-1 te evacueren.

Het toestel mag niet worden gebruikt voor het transport (pompen) van vloeistoffen, gasen of granulaat.

## Installatie

- Bij sterke vervuiling dient er een overeenkomstig filter gebruikt te worden
- Aansluiting opwaartse druk ejector  
Persluchtaansluiting P (1) / vacuümaansluiting V (2)  
Uitlaatluchtaansluiting / geluïdemper R (3) niet afsluiten
- Altijd het maximale aandrainmoment bij de bevestiging met M4-schroeven van 0,7 Nm aanhouden!
- Optionele kliklijst overeenkomstig het aantal ejectoren op lengte maken

## Características técnicas / Dati tecnici / Technische specificaties

Tipo / Tipo / Type	SLP 05	SLP 07	SBP 05	SBP 07	SBP 10	SBP 15	SBP 20	SBP 25
Tobera / Ugello / Spreier	0.5	0.7	0.5	0.7	1.0	1.5	2.0	2.5
Vacío máx. / Vuoto max. / Max. vacuüm [mbar]	830	850	840	850	850	850	850	850
Capacidad de aspiración / Capacità di aspirazione / Zuigvermogen [l/min]	8	15	7	16	37	70	124	215
Consumo de aire / Consumo d'aria / Luchtverbruik [l/min]	13	25	13	25	48	118	186	311
Consumo de aire / Pressione d'esercizio / Bedrijfsdruk [bar]	3-6							
Pres. de servicio ópt / pressione d'esercizio ott. / Opt. bedrijfsdruk [bar]	4.5							
Peso / Peso / Gewicht [g]	5	5	8	8	22	22		
Posición de montaje / Posizione di montaggio / Montagepositie	Opcional / A scelta / Willekeurig							
Diám. int. de tubo recomendado P/V / Diametro interno tubo flessibile consigliato P/V / Aanbevolen binnendiameter slang P/V [mm] <sup>1</sup>	2/2	2/2	2/2	2/2	4/6	4/6	6/8	6/8
Par de apriete máx. / Max. coppia di serraggio / Max. aandrainmoment [Nm]	-							
Margen de temperatura / Campo di temperatura / Temperatuurbereik [°C]	0...+50							
Medio de servicio / Mezzo di esercizio / Bedrijfsmiddel	Aire comprimido, sin aceitar o aceitado conforme a ISO 8573-1:2001, clase 7 <sup>2</sup> -4-4 <sup>3</sup> / Aria compressa non oliata o oliata secondo ISO 8573-1:2001, classe 7 <sup>2</sup> -4-4 <sup>3</sup> / Perslucht, olievrij of oliehoudend conform ISO 8573-1:2001, klasse 7 <sup>2</sup> -4-4 <sup>3</sup>							
Materiales utilizados / Materiali impiegati / Toegepaste materialen	PA6 GF30, alluminio, latón, POM, NBR, PE / PA6 GF30, aluminium, otone, POM, NBR, PE / PA6 GF30, aluminium, messing, POM, NBR, PE							
Eyectores por barra de clips / Eiettori per barra a clip / Ejectoren per kliklijst	-	-	11	-	7	-	5	-

<sup>1</sup> Los datos indicados se refieren a una longitud de tubo flexible máx. de 2 m. Si las longitudes de los tubos flexibles son mayores, se debe utilizar el diámetro de tubo al ejector con el tamaño mayor siguiente (recomendado) /  
<sup>2</sup> Recomendación clase 6 (5µm)  
<sup>3</sup> Máx. 30 mg/m<sup>3</sup> (2 gotas) con un paso nominal de q<sub>v</sub>=1000 l/min

<sup>1</sup> I valori dati si riferiscono a una lunghezza del tubo flessibile di max. 2m. Per lunghezze tubo maggiori, selezionare il diametro maggiore corrispondente.  
<sup>2</sup> Suggerimento classe 6 (5µm)  
<sup>3</sup> Max. 30 mg/m<sup>3</sup> (2 gocce) per una portata nominale di q<sub>v</sub>=1000 l/min

<sup>1</sup> De aangegeven waarden gelden voor een slanglengte van max. 2 m. Gebruik voor langere slangen de slangdiameter die een maat groter is  
<sup>2</sup> Aanbeveling klasse 6 (5µm)  
<sup>3</sup> Max. 30 mg/m<sup>3</sup> (2 druppels) bij een nominale doorlaat van q<sub>v</sub>=1000 l/min

## Accesorios / Accessori / Toebehoren

Tipo / Tipo / Type	SBP 05/07...	SBP 10/15...	SBP 20/25...
Silenciador / Silenziatore / Geluïdemper	10.02.01.00539	10.02.01.00540	10.02.01.00719
Barra de clips / Barra a clip / Kliklijst	10.02.01.00511		

## Dimensiones / Dimensioni / Afmetingen [mm]

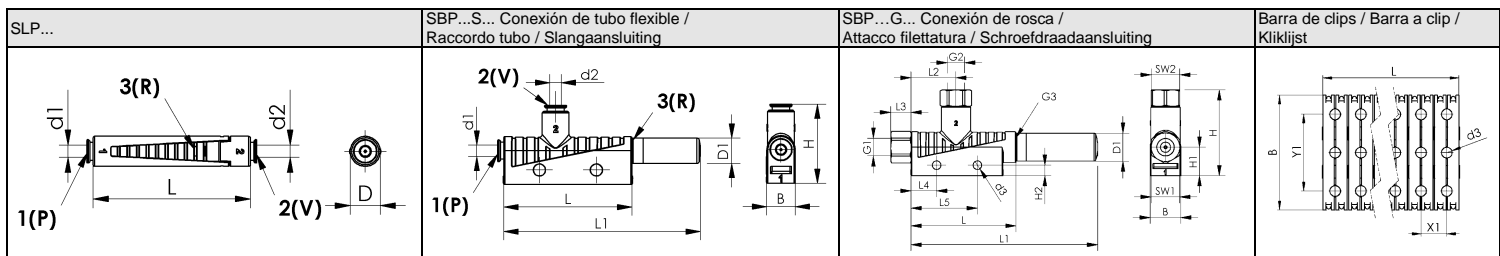

Type	B	D	D1	d1	d2	d3	G1	G2	G3	H	H1	H2	L	L1	L2	L3	L4	L5	SW1	SW2	X1	Y1
SLP 05/07...	-	10	-	4	4	-	-	-	-	-	-	-	57	-	-	-	-	-	-	-	-	-
SBP 05/07...S...	10	-	9	4	4	4,2	-	-	-	28	12	5,2	45	69	18,2	-	12,5	32,5	-	-	-	-
SBP 05/07...G...	10	-	9	-	-	4,2	M5	M5	M5	31	23	5,2	45	69	18,2	5	12,5	32,5	8	8	-	-
SBP 10/15...S...	15	-	13,5	6	8	4,2	-	-	-	40	14	5,2	51,5	91,5	22	-	12,5	32,5	-	-	-	-
SBP 10/15...G...	15	-	13,5	-	-	4,2	G1/8"	G1/8"	G1/8"	42	14	5,2	51,5	91,5	22	10	12,5	32,5	14	14	-	-
SBP 20/25...S...	20	-	-	8	10	4,2	-	-	-	-	-	5,2	-	-	-	-	12,5	32,5	-	-	-	-
SBP 20/25...G...	20	-	-	-	-	4,2	G1/4"	G3/8"	G3/8"	-	-	5,2	-	-	-	-	12,5	32,5	-	-	-	-
Barra / Barra / lijst	45	-	-	-	-	2,1	-	-	-	-	-	-	111,1	-	-	-	-	-	-	-	10,1	30

Reservado el derecho a realizar modificaciones por causas técnicas. No nos responsabilizamos de fallos en la impresión.

Con riserva di errori e modifiche tecniche

Technische wijzigingen en drukfouten voorbehouden



## Operating instructions ejector SCP / SMP

### 1. Technische Daten

**Funktionsprinzip:** Vakuum-Erzeugung mittels gesteuerter Druckluft nach dem Venturiprinzip.

**Verwendung:** Das Gerät dient zur Vakuum-Erzeugung das heißt zum Evakuieren von z. B. Sauggreifern zwecks Festhalten von Nutzlasten oder zum Evakuieren anderer Volumina. Als zu evakuierendes Medium sind Luft oder andere neutrale Gase gemäß EN 983 zugelassen. Das Gerät dient **nicht** zum Transport (Durchsaugen) von Flüssigkeiten und oder Granulaten.

**Medium:** gefilterte (SCP 10/15: max. 20 µm, SCP 20-30 und SMP 15-30: max. 40 µm) und geölte oder nicht geölte Druckluft oder neutrale Gase gemäß EN 983.

Ölempfehlung: Öl der Klasse H, (HM 32/HG 32) - ISO 3498  
Viskositätsklasse: VG 32 - ISO 3448 zum Beispiel HYSPIIN SP 32, MAGNAGLIDE D 32 (Castrol)

**zulässiger Betriebsdruck:** 4 ... 6 bar  
(opt. Betriebsdruck am Ejektoreingang: 5 ... 6 bar)

#### Einbaulage

Beliebig. Unter bestimmten Bedingungen (Staub; Öl o. a. Flüssigkeiten saugseitig) kann eine Einbaulage mit senkrecht nach unten gerichtetem Filter empfehlenswert sein.

#### Versorgungsspannung (Schutzkleinspannung PELV)

Magnetventile: +24 V DC -5% / +10%  
Vakuum-Schalter: +10.8 ... 30 V DC

#### Zul. Temperaturbereich

Umgebung: 0°C ... +45°C  
zu evakuierendes Medium: 0°C ... +60°C

#### Verwendete Werkstoffe

Grundkörper	Aluminiumlegierung eloxiert
Filtergehäuse	PC
Filtereinsatz	Poroplast (PE-porös); Porenweite 50 µm
Schalldämpfer	Poroplast (PE-porös)
Deckel Schalldämpfer	POM
Schrauben	Stahl schwarz chromatisiert / verzinkt
Innentile	Messing; POM; Edelstahl; Al
Dichtungen	NBR
Schmierung	Silikonfrei

#### Magnetventile

Gerät	Spannung / Toleranz	Leistung	ED	Schaltzeit E/A	Handbetätigung	Schutzbeschaltung	Schaltzustand	Schutzart
SCP 10-15	24 V DC -5/+10%	1.3 W	100 %	8 ms / 10 ms	tastend	Z-Diode (im Ventil)	LED - rot	IP 40 (m. Stecker)
SMP / SCP 20-30	24 V DC -5/+10%	2.5 W	100 %	10 ms / 12 ms	tastend	Varistor (im Stecker)	LED - rot	IP 65 (m. Stecker)

#### Solenoid Valves

Unit	Voltage / Tolerance	Power	Duty cycle	Switching time on/off	Manual actuation	Protective circuit	Status indicator	Enclosure type
SCP 10-15	24 V DC -5/+10%	1.3 W	100 %	8 ms / 10 ms	Push button	Z diode (in valve)	LED - red	IP 40 (with plug)
SMP / SCP 20-30	24 V DC -5/+10%	2.5 W	100 %	10 ms / 12 ms	Push button	Varistor (in plug)	LED - red	IP 65 (with plug)

#### Typbezeichnungen

SCP	Schmalz Compact Pump
SMP	Schmalz Mega Pump
10 ... 30	Düsendurchmesser=1.0 .... 3.0 mm
NO / NC	Ruhestellung Saugventil (Magnetventil), NO = Stromlos offen, NC = stromlos geschlossen
FS	ohne Magnetventile, geeignet für Fremdsteuerung
AS	mit Abblasventil und Sicherheitsrückschlagventil
V ...	mit Vakuum-Schalter
R ...	mit interner Regelung (Luftsparautomatik)

### 1. Technical Data

**Principle of operation:** vacuum generation by means of controlled compressed air (Venturi principle).

**Application:** the unit is intended for vacuum generation, i.e. for evacuation of suction pads in order to secure loads, or for evacuation of other containers. It may be used for removal of air or other neutral gases in accordance with EN 983.

The unit is **not** intended for the transport (pumping) of liquids or granulates.

**Medium:** filtered (SCP 10/15: max. 20 µm, SCP 20-30 and SMP 15-30: max. 40 µm), oily or oil-free compressed air or neutral gases in accordance with EN 983.

Recommended oil: oil of class H, (HM 32/HG 32) - ISO 3498  
Viscosity class: VG 32 - ISO 3448, such as HYSPIIN SP 32, MAGNAGLIDE D 32 (Castrol)

**Permissible operating pressure:** 4....6 bar  
(optimum pressure at ejector inlet: 5 ... 6 bar)

#### Installation orientation

Any. Under certain conditions (dust; oil or similar liquids on the inlet side) it may be advisable to install with the filter pointing vertically downwards.

#### Supply voltage (Protected extra-low voltage PELV)

Solenoid valves: +24 V DC -5% / +10%  
Vacuum switches: +10.8 ... 30 V DC

#### Permissible temperature range

Ambient temperature: 0°C ... +45°C  
Medium to be evacuated: 0°C ... +60°C

#### Materials

Body	Aluminium alloy, anodised
Filter casing	PC
Filter insert	Poroplast (porous PE); pore size 50 µm
Silencer	Poroplast (porous PE)
Silencer cover	POM
Screws	Steel, black-chromated / galvanized
Internal parts	Brass; POM; stainless steel; aluminium
Gaskets	NBR
Lubrication	Silicone-free

**Ejector SCP 10 - 15**  
(auch geregelte Version ...RD/RE / also regulated version ...RD/RE)

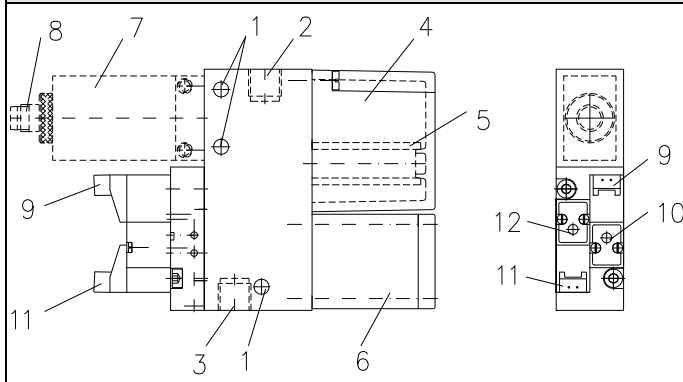

**Ejectors SMP 15 - 30 and SCP 20 - 30**  
(auch geregelte Version ...RD/RE / also regulated version ...RD/RE)

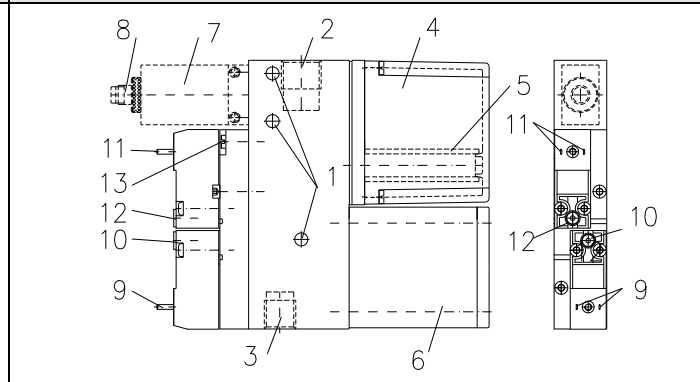

**Ejectors SCP 10 - 15 ...FS**  
(mit Fremdsteuerung / with external control)

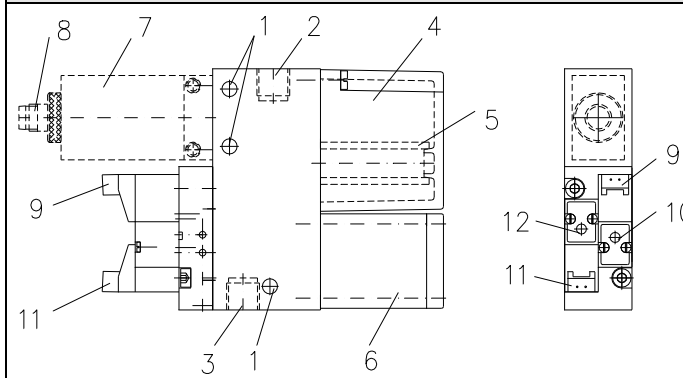

**Ejectors SMP 15 - 30 ... / SCP 20 - 30**  
(mit Fremdsteuerung / with external control)

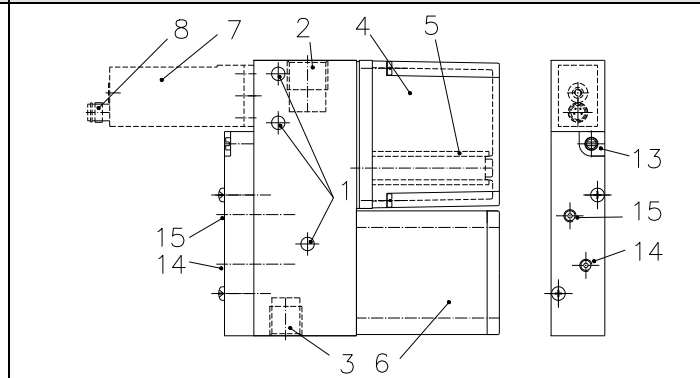

**Ejectors SCP 10 - 15 ...FS-RP (mit Fremdsteuerung, pneumatisch geregelt / with external control, pneumatically regulated)**

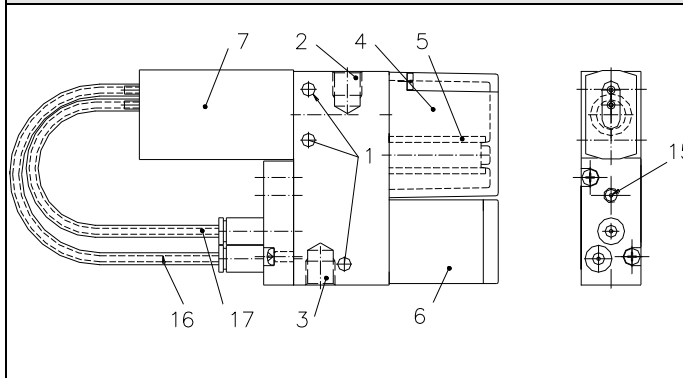

**Ejectors SMP 15 - 30 ... / SCP 20 - 30 ... FS-RP (mit Fremdsteuerung, pneumatisch geregelt / with external control, pneumatically regulated)**

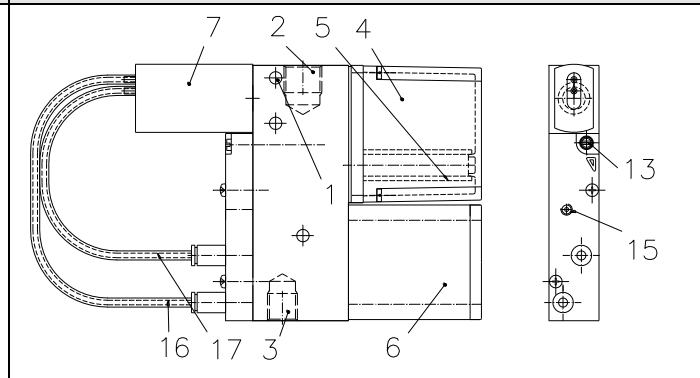

- 1** Befestigungsbohrungen des Ejektors  
SCP 10-15: Durchmesser 4,5 mm  
SMP / SCP 20-30: Durchmesser 5,5 mm
- 2** Vakuumanschluss  
SCP 10-15: Anschlussgewinde G1/8"  
SMP / SCP 20-30: Anschlussgewinde G3/8"
- 3** Druckluftanschluss  
SCP 10-15: Anschlussgewinde G1/8"  
SMP / SCP 20-30: Anschlussgewinde G1/4"
- 4** Filtergehäuse
- 5** Filterelement
- 6** Schalldämpfer
- 7** Vakuum-Schalter
- 8** Elektrischer Anschluss Vakuum-Schalter (außer ... VPM)  
Bei allen Geräten: M8 x 1
- 9** Elektrischer Anschluss Pilotventil „Saugen“  
SCP 10-15: formschlüssig rastend; nicht genormt  
SMP / SCP 20-30: Steckanschluss nach DIN 43650 Form C
- 10** Handhilfsbetätigung (tastend) Pilotventil „Saugen“
- 11** Elektrischer Anschluss Pilotventil „Abblasen“
- 12** Handhilfsbetätigung (tastend) Pilotventil „Abblasen“
- 13** Drosselschraube Abwurfimpuls (nur bei SMP...)
- 14** Steuerluftanschluss „Saugen“ Anschlussgewinde M5
- 15** Steuerluftanschluss „Abblasen“ Anschlussgewinde M5
- 16** Druckluftversorgung pneumatischer Vakuum-Schalter  
(nur bei Version ... FS-RP)
- 17** Steuerleitung „Saugen“ (nur bei Version ... FS-RP)

- 1** Mounting holes for ejector  
SCP 10-15: Diameter 4.5 mm  
SMP / SCP 20-30: Diameter 5.5 mm
- 2** Vacuum connector  
SCP 10-15: Thread G1/8"  
SMP / SCP 20-30: Thread G3/8"
- 3** Compressed-air connector  
SCP 10-15: Thread G1/8"  
SMP / SCP 20-30: Thread G1/4"
- 4** Filter housing
- 5** Filter element
- 6** Silencer
- 7** Vacuum switch
- 8** Electrical connector for vacuum switch (except ... VPM)  
On all versions: M8 x 1
- 9** Electrical connector for pilot valve "Suction"  
SCP 10-15: positive locking, not standardized  
SMP / SCP 20-30: connector to DIN 43650, shape C
- 10** Auxiliary manual actuation (push button) for pilot valve "Suction"
- 11** Electrical connector for pilot valve "Blow off"
- 12** Auxiliary manual actuation (push button) for pilot valve "Blow off"
- 13** Throttle screw for blow-off pulse (SMP... only)
- 14** Control air connection „Suction“ Thread M5
- 15** Control air connection „Blow off“ Thread M5
- 16** Compressed air for pneumatic vacuum switch  
(only on version ... FS-RP)
- 17** Control line "Suction" (only on version ... FS-RP)

## 1.1 Ejector SMP

### Saugvermögen / Suction capacity

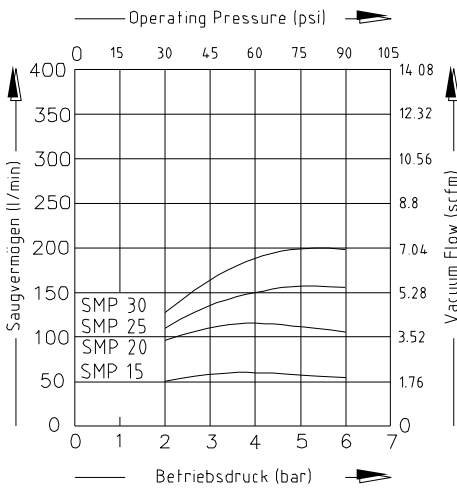

### Vakuum / Vacuum

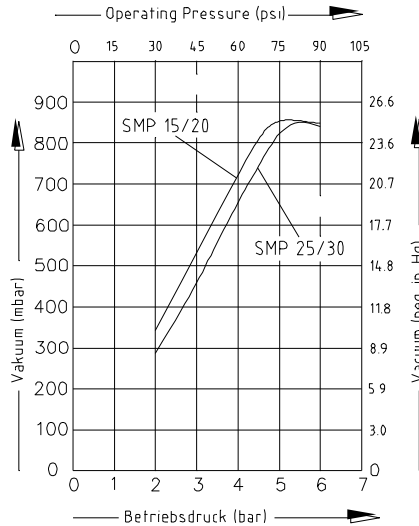

### Luftverbrauch / Air consumption

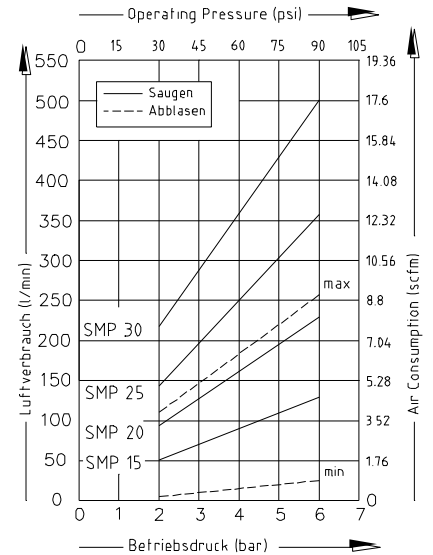

### Technische Daten / Technical Data

Typ / Type	Düsen-Ø / Nozzle Ø	Max. Vakuum / Max. vacuum	Max. Saugvermögen / Max. suction capacity	Betriebsdruck / Operating pressure	Gesamtgewicht / Total weight
SMP 15	1.5 mm	85 %	65 l/min	5 ... 6 bar	0,465 kg
SMP 20	2 mm	85 %	116 l/min	5 ... 6 bar	0,465 kg
SMP 25	2.5 mm	85 %	161 l/min	5 ... 6 bar	0,485 kg
SMP 30	3 mm	85 %	200 l/min	5 ... 6 bar	0,485 kg

### Saugvermögen bei verschiedenen Evakuierungsgraden in l/min / Suction capacity at various degrees of evacuation in l/min

Typ	-50	-100	-200	-300	-400	-500	-600	-700	-800
SMP 15	62	58	50	41	32	21	16	9	4
SMP 20	108	101	90	78	63	48	36	18	5
SMP 25	149	136	123	107	86	66	49	25	7
SMP 30	184	168	153	132	107	82	61	31	9

### Luftverbrauch und Schallpegel / Air consumption and noise level

Typ / Type	Luftverbrauch in l/min bei 5 bar Speisedruck / Air consumption in l/min at a supply pressure of 5 bar			Schallpegel bei Saugen / Noise level during suction	
	Saugen / Evacuating	Abblasen min. / Blowing off, min.	Abblasen max. / Blowing off, max.	frei / Without load	angesaugt / With load attached
SMP 15	117	170	250	74	74
SMP 20	190	170	250	78	76
SMP 25	310	170	250	82	72
SMP 30	420	170	250	82	82

## 1.2 Ejector SCP

### Saugvermögen / Vacuum Flow

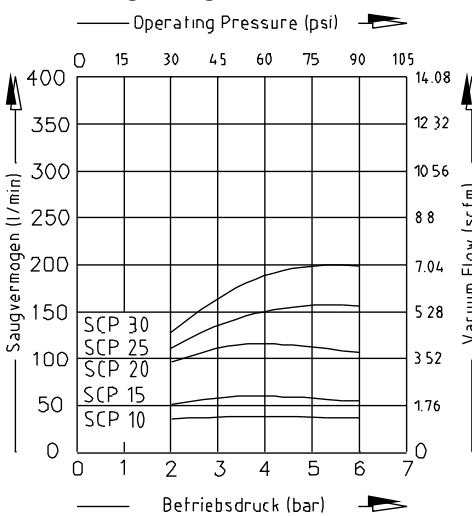

### Vakuum / Vacuum

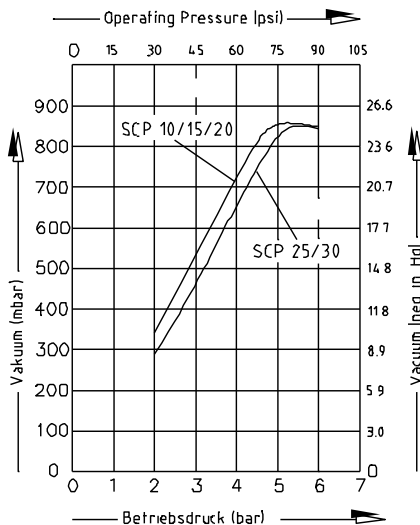

### Luftverbrauch / Air consumption

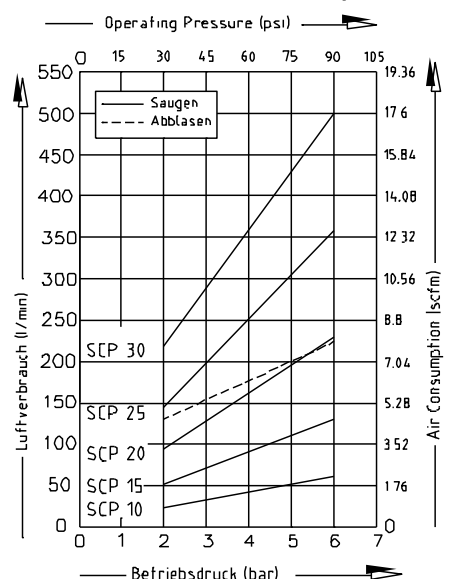

## Technische Daten / Technical Data

Typ / Type	Düsen-Ø / Nozzle Ø	Max. Vakuum Max. vacuum	Max. Saugvermögen Max. Suction capacity	Betriebsdruck Operating pressure	Gesamtgewicht / Total weight
SCP 10	1 mm	85 %	37 l/min	5 ... 6 bar	0,275 kg
SCP 15	1,5 mm	85 %	65 l/min	5 ... 6 bar	0,275 kg
SCP 20	2 mm	85 %	116 l/min	5 ... 6 bar	0,465 kg
SCP 25	2,5 mm	85 %	161 l/min	5 ... 6 bar	0,485 kg
SCP 30	3 mm	85 %	200 l/min	5 ... 6 bar	0,485 kg

## Saugvermögen bei verschiedenen Evakuierungsgraden in l/min / Suction capacity at various degrees of evacuation in l/min

Typ	-50	-100	-200	-300	-400	-500	-600	-700	-800
SCP 10	35,4	33,2	28,8	24	19,4	16	11,2	6	1,4
SCP 15	62	58	50	41	32	21	16	9	4
SCP 20	108	101	90	78	63	48	36	18	5
SCP 25	149	136	123	107	86	66	49	25	7
SCP 30	184	168	153	132	107	82	61	31	9

## Luftverbrauch und Schallpegel / Air consumption and noise level

Typ / Type	Luftverbrauch in NI/min bei 5 bar Speisedruck / Air consumption in NI/min at a supply pressure of 5 bar			Schallpegel bei Saugen / Noise level during suction	
	Saugen / Evacuating	Abblasen min. / Blowing off, min.	Abblasen max. / Blowing off, max.	frei / Without load	angesaugt / With load attached
SCP 10	53	200		68	66
SCP 15	117	200		68	68
SCP 20	190	200		78	76
SCP 25	310	200		82	72
SCP 30	420	200		82	82

## 2. Inbetriebnahme / Commissioning

### Voraussetzungen: Lesen Sie gründlich die Benutzer- und Sicherheitshinweise

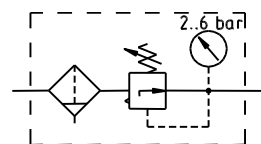

- ⇒ ausreichend gewartete Druckluft verwenden (siehe Technische Daten) (Qualität der Druckluft ist von ausschlaggebender Bedeutung für eine optimale Lebensdauer des Gerätes)
- ⇒ Bei Verwendung von geölter Druckluft, diese immer beibehalten, da das Öl die Initialschmierung im Gerät entfernt hat (kein Wechsel auf nicht geölte Druckluft vornehmen!)

### Prerequisites: read the user and safety instructions carefully

- ⇒ Use correctly processed compressed air (see the Technical Data) (the quality of the compressed air is of decisive importance for achieving an optimum operating lifetime).
- ⇒ If oily compressed air is used, it must always be used, since the oil removes the initial lubrication from the unit. Do not change to oil-free compressed air later!

### 2.1 Einbau

#### Ein-/ Ausbauräume

- Beachten Sie die Ein-/ Ausbauräume entsprechend Zeichnungen
- ⇒ zum einfachen Filterwechsel
- ⇒ zur knickfreien Verlegung der elektrischen Anschlusskabel
- ⇒ zum quetschfreien Verlegen der pneumatischen Leitungen/Schläuche

### 2.1 Installation

#### Space for installation and removal

- Please note the installation / removal spaces shown in the drawings, since these
- ⇒ simplify changing of the filter,
- ⇒ permit laying the electrical cables without kinks,
- ⇒ permit laying of the pneumatic hoses without pinching them.

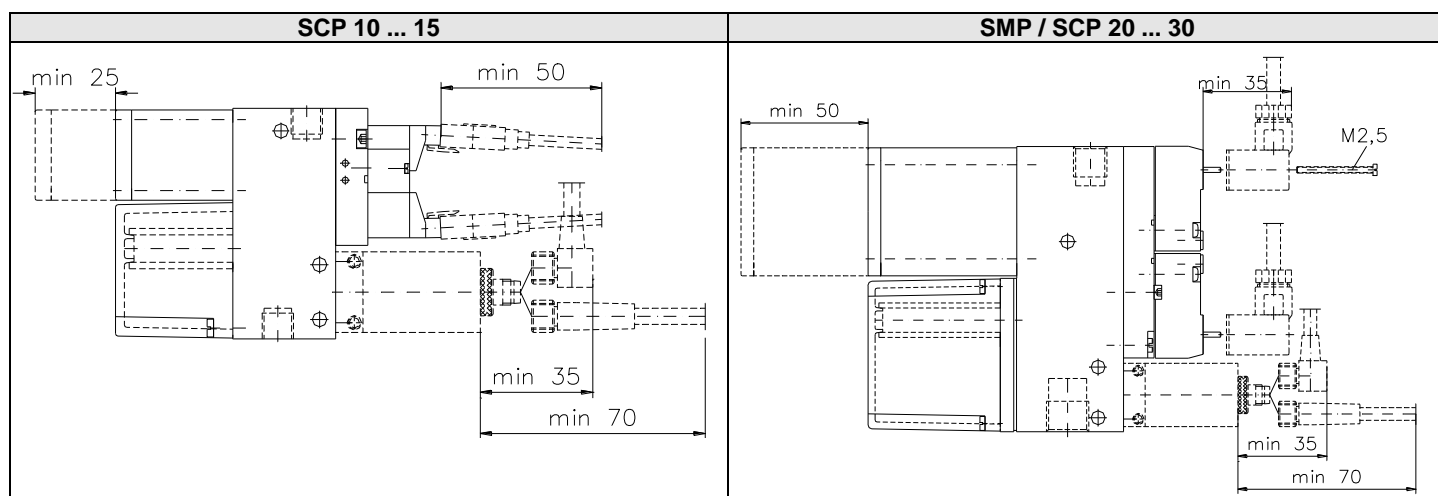

## 2.2 Elektrischer Anschluss

Befestigen Sie die zugehörigen Stecker bzw. Kabel an den Magnetventilen und dem Vakuum-Schalter (sofern vorhanden).

Die zum jeweiligen Gerät passenden Stecker bzw. Kabel entnehmen Sie bitte der nachfolgenden Zubehörtabelle (Pkt.5)

### SCP 10/15

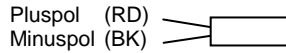

Stecker für Magnetventile werden gesteckt bis zum Einrasten. Zur Demontage Rasthebel betätigen.  
**Achtung!** Beim Anlegen von +24 V DC auf richtige Polarität achten! Es besteht kein Verpolungsschutz!

### SMP/SCP 20-30

Stecker für Ventile werden mit Schraube befestigt. Beim Anlegen von +24 V DC muss keine Polarität beachtet werden.

### SCP/SMP mit Vakuum-Schalter (außer ... VPM)

Stecker werden formschlüssig aufgesteckt und mit Überwurfmutter schraubgesichert. Anschlüsse für Betriebsspannung sind verpolungsgeschützt.

### SCP/SMP ... RE/RD (elektr. geregelte Version)

Kabel vom Anschlussverteiler (Zuordnung (a) (b) (c) beachten)

## 2.2 Electrical Connections

Connect the related plugs and/or cables to the solenoid valves and the vacuum switch (if fitted).

See the table of accessories in Section 5 for the correct plug and/or cable for each unit:

### SCP 10/15

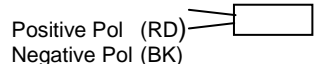

Snap the plugs into the sockets on the solenoid valves. To remove them, press down on the locking levers.  
**Caution!** when connecting +24 V DC, ensure that the polarity is correct, since there is no protection against reverse polarity!

### SMP/SCP 20-30

Valve plugs are secured with screws. The +24 V DC supply voltage may be connected with either polarity.

### SCP/SMP with vacuum switch (except ... VPM)

Snap the plugs into the sockets and secure them with the union nut. The supply voltage connections have reverse-polarity protection.

### SCP/SMP ... RE/RD (electrically regulated versions)

Cable to distributor (note the positions of cables (a) (b) (c))

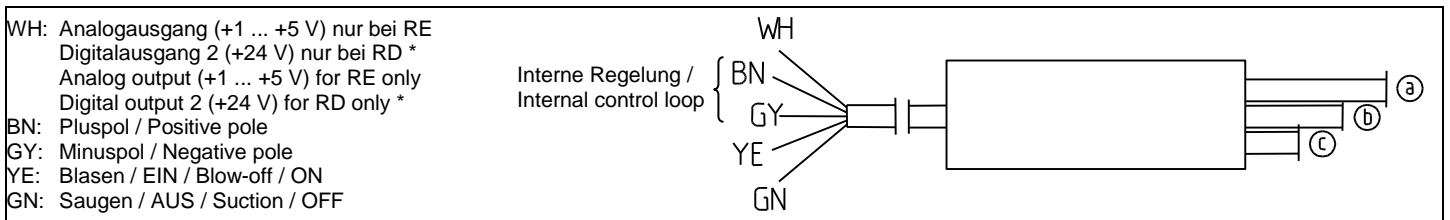

**Achtung:** Am Anschluss (WH) darf keine Spannung angelegt werden!

\* Digitalausgang 2 unabhängig von interner Regelung  
(Digitalausgang 1 wird für interne Regelung verwendet)

**Caution:** do not connect any voltage to (WH)!

\* Digital output 2 independent of internal control loop  
(Digital output 1 is used for internal adjustment)

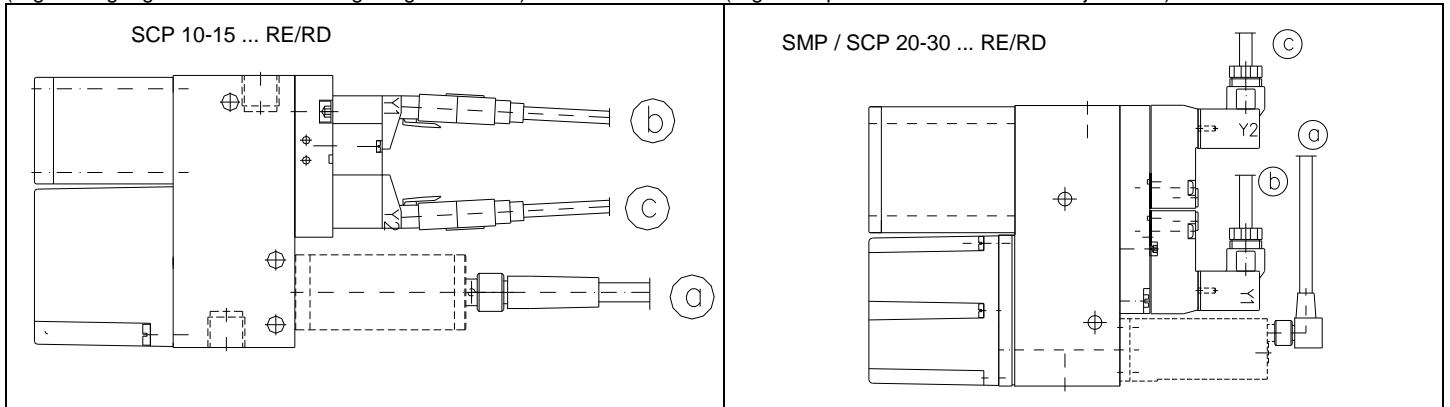

## Kabelfarben / Cable colours

BN = braun	GY = grau	YE = gelb	GN = grün	WH = weiß	RD = rot	BK = schwarz
BN = brown	GY = grey	YE = yellow	GN = green	WH = white	RD = red	BK = black

## 2.3 Pneumatischer Anschluss

- ⇒ Verwenden Sie für das jeweilige Gerät nur die empfohlenen Schlauch- bzw. Rohrdurchmesser (siehe nachfolgende Tabelle)
- ⇒ Sorgen Sie dafür, dass sich keine Schmutzpartikel oder Fremdkörper in den Anschlüssen des Gerätes bzw. in den Schlauchleitungen befinden.
- ⇒ Ein zu klein gewählter Innendurchmesser druckluftseitig **3** bewirkt, dass dem Gerät nicht genügend Druckluft für die optimale Leistung zugeführt wird.
- ⇒ Ein zu klein gewählter Innendurchmesser vakuumsseitig **2** bewirkt einen zu hohen Strömungswiderstand entlang der Schlauchwandung, was sich negativ auf die Saugleistung und damit auf die Ansaugzeiten auswirkt, gleichzeitig bewirkt der hohe Strömungswiderstand auch eine Verlängerung der Abblaszeiten.
- ⇒ Schlauchleitungen sollten möglichst kurz verlegt werden, um die Reaktionszeiten möglichst klein zu halten.

Schlauchleitungen knick- und quetschfrei verlegen.

## 2.3 Pneumatic Connections

- ⇒ Use only hoses or pipes with the recommended internal diameter for the unit being connected (see the table below).
- ⇒ Ensure that there are no particles of dirt or other foreign objects in the connectors and hoses.
- ⇒ If the internal diameter on the compressed-air side **3** is too small, the unit will receive insufficient air for optimum operation.
- ⇒ If the internal diameter on the vacuum side **2** is too small, the flow resistance will be too high, reducing the suction capacity and increasing the pick-up times and the blow-off times.
- ⇒ Hoses should be kept as short as possible in order to minimize the reaction times.

**Ensure that hoses are not kinked or pinched.**



## Empfohlene Schlauchdurchmesser

Gerät	Druckluftseitig Innen-Ø	Vakuumseitig Innen-Ø	Fremdsteuerung steuerluftseitig Innen-Ø
SCP 10...	2 mm	4 mm	2 mm
SCP 15...	4 mm	6 mm	2 mm
SMP 15...	4 mm	6 mm	2 mm
SMP 20/SCP 20...	6 mm	9 mm	2 mm
SMP 25/SCP 25...	9 mm	9 mm	2 mm
SMP 30/SCP 30...	9 mm	12 mm	2 mm

Der empfohlene Innendurchmesser bezieht sich auf eine max. Länge von 2 m. Bei größeren Längen den nächst größeren Querschnitt verwenden

## 2.4 Funktionskontrolle (gilt nicht für geregelte Version ... RE/RD/RP)

### 2.4.1 Geräte mit integrierten Elektromagnetventilen

Nach dem Herstellen aller elektrischen und pneumatischen Verbindungen beaufschlagen Sie das entsprechende Gerät mit Druckluft.

- ⇒ **SMP/SCP... NO...**: Gerät wird in den Zustand „Saugen“ versetzt.
- ⇒ **SMP/SCP... NC...**: Gerät bleibt im Zustand „Nicht Saugen“.

Legen Sie am Magnetventil „Saugen“ **9** die Versorgungsspannung an.

- ⇒ **SMP/SCP... NO...**: Gerät wird in den Zustand „Nicht Saugen“ versetzt
- ⇒ **SMP/SCP... NC...**: Gerät wird in den Zustand „Saugen“ versetzt.

Legen Sie am Magnetventil „Abblasen“ **11** die Versorgungsspannung an.

- ⇒ **SMP/SCP... NO...**: Gerät wird in den Zustand „Abblasen“ versetzt (gleichzeitig die Versorgungsspannung an **9** anstehen lassen, da sich sonst die Zustände „Saugen“ und „Abblasen“ überlagern).
- ⇒ **SMP/SCP... NC...**: Gerät wird in den Zustand „Abblasen“ versetzt. (gleichzeitig Magnetventil **9** spannungsfrei schalten, da sich sonst die Zustände „Saugen“ und „Abblasen“ überlagern).

### 2.4.2 Geräte mit Fremdsteuerung (gilt nicht für Version ... FS RP)

Beaufschlagen Sie das Gerät am Anschluss **3** sowie an den Anschlüssen **14** und **15** mit Druckluft (über bauseits erforderliche externe Steuerventile).

**Achtung:** An allen Anschlüssen muss identisches Druckniveau anliegen (siehe Pneumatikpläne im Kapitel 8 und 9)

- ⇒ Gerät wird in den Ruhezustand „Nicht Saugen“ versetzt.

Unterbrechen Sie die Druckluftzufuhr am Anschluss **14**

- ⇒ Gerät wird in den Zustand „Saugen“ versetzt.

Unterbrechen Sie die Druckluftzufuhr am Anschluss **15**.

Beaufschlagen Sie gleichzeitig Anschluss **14** wieder mit Druckluft.

**Gerät wird in den Zustand „Abblasen“ versetzt.**

### 2.5 Vakuum-Schalter einstellen

Legen Sie am Vakuum-Schalter die Versorgungsspannung an (Bei der Version mit pneumatischem Vakuum-Schalter **VPM** Druckluft anlegen).

- ⇒ **SMP/SCP... VM/VE/VEH/VPM**: Durch Drehen der Stellschraube (7.1) stellen Sie den Schaltpunkt auf den gewünschten Wert (Kontrolle mittels Vakuummanometer empfehlenswert z. Bsp. Type: VAM 63/1 U (Best-Nr.: 10.07.02.00004)  
Das Erreichen des Schaltpunktes wird signalisiert bei:
  - ... VE/VEH/RE/RD durch Aufleuchten der LED (7.2)
  - ... VM/VD-NO (Schließer) durch Aufleuchten der LED (7.2)
  - ... VM/VD-NC (Öffner) durch Erlöschen der LED (7.2)
  - ... VPM-NO durch Sperren der Druckluft am Ausgang (7.6)
  - ... VPM-NC durch Freischalten der Druckluft am Ausgang (7.6)
- ⇒ **SMP/SCP... VEH**: Durch Drehen der Stellschraube (7.3) stellen Sie die Hysterese auf den gewünschten Wert. (Kontrolle mittels Vakuummanometer empfehlenswert)
- ⇒ **SMP/SCP... VD**: Programmieren Sie mittels Folientastatur (7.1/7.3) Schaltpunkt und Hysterese nach Ihren Anforderungen mit gleichzeitiger Kontrolle der programmierten und der gemessenen Werte am LED-Display (7.4)

## Recommended hose diameters

Unit	Internal Ø on pressure side	Internal Ø on vacuum side	External control control air side internal-Ø
SCP 10...	2 mm	4 mm	2 mm
SCP 15...	4 mm	6 mm	2 mm
SMP 15...	4 mm	6 mm	2 mm
SMP 20/SCP 20...	6 mm	9 mm	2 mm
SMP 25/SCP 25...	9 mm	9 mm	2 mm
SMP 30/SCP 30...	9 mm	12 mm	2 mm

These diameters are for a maximum hose length of 2 m.

For longer hoses, select the next larger diameter.

## 2.4 Operational Check (does not apply to regulated versions ... RE/RD/RP)

### 2.4.1 Units with integrated solenoid valves

After making all electrical and pneumatic connections, connect compressed air to the unit.

- ⇒ **SMP/SCP... NO...**: unit is switched to the state "Suction".
- ⇒ **SMP/SCP... NC...**: unit remains in the state "No suction".

Connect the supply voltage to the solenoid valve "Suction" **9**.

- ⇒ **SMP/SCP... NO...**: The unit switches to the state "No suction".
- ⇒ **SMP/SCP... NC...**: The unit switches to the state "Suction".

Connect the supply voltage to the solenoid valve "Blow off" **11**.

- ⇒ **SMP/SCP... NO...**: The unit switches to the state "Blow off".  
(Leave the supply voltage connected to **9**, since the states "Suction" and "Blow off" will be superimposed on each other and neither will be fully active.)
- ⇒ **SMP/SCP... NC...**: The unit switches to the state "Blow off".  
(Switch the solenoid valve **9** in idle status, since the states "Suction" and "Blow off" will be superimposed on each other)

### 2.4.2 Units with external control (does not apply to versions ... FS RP)

Apply compressed air to the unit (via locally provided control valves) to connector **3** and to connectors **14** and **15**.

**Caution:** the same pressure must be applied to all three connectors (see pneumatic diagrams in Sections 8 and 9).

- ⇒ The unit is now in the state "No suction".

Disconnect the compressed air supply from connector **14**.

- ⇒ The unit switches to the state "Suction".

Disconnect the compressed air supply from connector **15** and connect the compressed air supply to connector **14** again.

**The unit switches to the state "Blow off".**

### 2.5 Adjust Vacuum Switch

Connect the supply voltage to the vacuum switch (on the version with pneumatic vacuum switch **VPM**, connect compressed air).

- ⇒ **SMP/SCP... VM/VE/VEH/VPM**: Turn the adjusting screw (7.1) to set the switching point to the desired value (we recommend checking the setting with a vacuum gauge such as Type VAM 63/1 U, Order No.: 10.07.02.00004).  
The fact that the switching point has been reached is indicated as follows:
  - ... VE/VEH/RE/RD: the LED (7.2) lights
  - ... VM/VD-NO (normally open): the LED (7.2) lights
  - ... VM/VD-NC (normally closed): the LED (7.2) is extinguished
  - ... VPM-NO: the compressed air at the output (7.6) is switched off
  - ... VPM-NC: the compressed air at the output (7.6) is switched on
- ⇒ **SMP/SCP... VEH**: Turn the adjusting screw (7.3) to set the hysteresis to the desired value (we recommend checking the setting with a vacuum gauge).
- ⇒ **SMP/SCP... VD**: Programming the switching point and the hysteresis as desired with the membrane keypad (7.1/7.3). The programmed and measured (actual) values are shown on the LED display (7.4)

Vakuum-Schalter (7) für Ejektor SMP / SCP Vacuum switch (7) for ejector SMP / SCP...

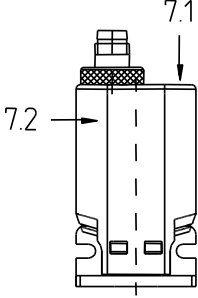
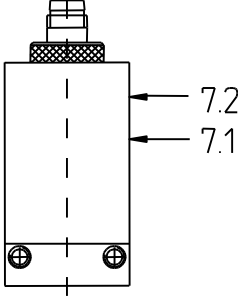
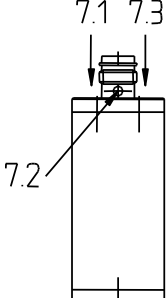
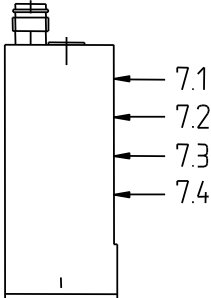
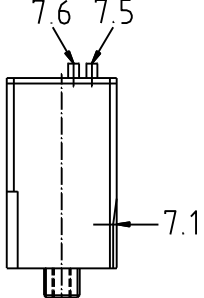
... VM	... VE	... VEH / RE	... VD / RD	... VPM
				
VS-V-A-EM-M8	VS-V-A-PNP-S	VS-V-PNP	VS-V-D-PNP	VS-V-PM

- 7.1 Potentiometer für Schaltpunkteinstellung bzw. Folientastatur für Schaltprogrammierung (bei Version ... VD/RD)
- 7.2 LED für Schaltzustandsanzeige
- 7.3 Potentiometer für Hystereseeinstellung bzw. Folientastatur für Hystereseprogrammierung (bei Version ... VD/RD)
- 7.4 LED- Display (bei Version ... VD/RD)
- 7.5 Pneumatischer Eingang (bei Version ... VPM)
- 7.6 Pneumatischer Ausgang (bei Version ... VPM)

- 7.1 Potentiometer switching point adjustment or membrane keypad for programming the switching point (on versions ...VD/RD )
- 7.2 LED for switching status indication
- 7.3 Potentiometer for hysteresis adjustment or membrane keypad for programming the hysteresis (on versions ... VD/RD)
- 7.4 LED display (on versions ... VD/RD)
- 7.5 Pneumatic input (on version ... VPM)
- 7.6 Pneumatic output (on version ... VPM)

Beachten Sie auch die separaten Bedienungsanleitungen der jeweiligen Vakuum-Schalter.

2.6 Geräte mit interner Regelung (Luftsparautomatik) (Serie ... RE/RD/VP)

2.6.1 Regelung elektrisch (... RE/RD)

Legen Sie an den Anschlüssen **BN(+)** und **GY(-)** die Versorgungsspannung an (**permanent**). Setzen Sie das Gerät mit einem angeschlossenen Sauggreifer auf das anzusaugende möglichst dichte Werkstück oder eine andere geeignete glatte und dichte Oberfläche.

- ⇒ **SMP/SCP...NO ...:** Gerät wird durch das Ansprechen der internen Regelung in den Zustand „Nicht Saugen“ versetzt. Das eingebaute Rückschlagventil hält je nach Dichtheit der Verschlauchung und des Werkstückes diesen Zustand so lange aufrecht, bis das Vakuumniveau unter den voreingestellten Regelbereich (Hysteresis vom Vakuum-Schalter) fällt und damit der Vorgang „Saugen“ wieder aktiviert wird, bis das Vakuumniveau wieder den voreingestellten Schaltpunkt erreicht und der Vorgang „Saugen“ unterbrochen wird.
- ⇒ **SMP/SCP... NC ...:** Vorgang „Saugen“ wird aktiviert, anschließend wird das Gerät durch das Ansprechen der **internen Regelung** in den Zustand „Nicht Saugen“ versetzt. (weiterer Ablauf siehe oben)

Legen Sie am Anschluss **GN** +24 VDC an.

- ⇒ Vorgang „Saugen“ wird unterbrochen, unabhängig vom Schaltzustand der internen Regelung.

Legen Sie am Anschluss **YE** +24 V DC an.

- ⇒ Vorgang „Abblasen“ wird aktiviert, bei **gleichzeitiger** Unterbrechung vom Vorgang „Saugen“, **unabhängig** vom Schaltzustand der **internen Regelung**. Anschluss **GN** braucht hierbei **nicht** belegt zu werden!

2.6.2 Regelung pneumatisch (... RP)

Beaufschlagen Sie das Gerät am Anschluss **3** und über das bauseits erforderliche externe Steuerventil „Abblasen“ am Anschluss **15** mit Druckluft.

**Achtung:** An beiden Anschlüssen muss identisches Druckniveau anliegen (siehe Pneumatikplan im Kapitel 8 und 9). Setzen Sie das Gerät mit einem angeschlossenen Sauggreifer auf das anzusaugende möglichst dichte Werkstück oder eine andere geeignete glatte und dichte Oberfläche.

- ⇒ Gerät wird durch das Ansprechen der internen Regelung in den Zustand „Nicht Saugen“ versetzt. Das eingebaute Rückschlagventil hält je nach Dichtheit der Verschlauchung und des Werkstückes diesen Zustand so lange aufrecht, bis das Vakuumniveau unter den voreingestellten Regelbereich (Hysteresis vom Vakuum-Schalter) fällt und damit der Vorgang „Saugen“ wieder aktiviert wird, bis das Vakuumniveau wieder den voreingestellten Schaltpunkt erreicht und der Vorgang „Saugen“ unterbrochen wird.

Sperren Sie über das bauseitig erforderliche externe Steuerventil „Abblasen“ die Druckluftzufuhr am Anschluss **15**.

- ⇒ Vorgang „Abblasen“ wird aktiviert.

See also the separate Operating Instructions for the vacuum switch being used.

2.6 Units with internal regulation (automatic air-saving) (Serie ... RE/RD/VP)

2.6.1 Electrical regulation... RE/RD)

Connect the supply voltage (**permanently**) to the terminals **BN (+)** and **GY (-)**. Connect a suction pad to the unit and place the pad on the work piece to be picked up (which should be as air-tight as possible) or on some other suitably flat and air-tight surface.

- ⇒ **SMP/SCP...NO ...:** the internal control loop sets the unit to the state "**No suction**". The built-in non-return valve maintains this state, depending on the porosity of the hoses and work piece, until the vacuum drops below the preset lower limit (hysteresis of the vacuum switch), when the function "**Suction**" is again activated until the vacuum reaches the upper limit value, when it is again switched off.
- ⇒ **SMP/SCP...NC ...:** "**Suction**" is activated and the **internal control loop** then switches to the state "**No suction**". Further operations are then as described above.

Connect +24 VDC to the terminal **GN**.

- ⇒ The function "**Suction**" is deactivated, **regardless** of the switching status of the **internal control loop**.

Connect +24 VDC to the terminal **YE**.

- ⇒ The function "**Blow off**" is activated and the function "**Suction**" is deactivated **simultaneously, regardless** of the switching status of the **internal control loop**. Terminal **GN** does **not** need to be connected in this case!

2.6.2 Pneumatic Regulation (... RP)

Connect compressed air directly to connector **3** and via a locally provided control valve to connector **15**.

**Caution:** the same pressure must be connected to both connectors (see pneumatic diagram in Sections 8 and 9).

Connect a suction pad to the unit and place the pad on the work piece to be picked up (which should be as air-tight as possible) or on some other suitably flat and air-tight surface.

- ⇒ the internal control loop sets the unit to the state "**No suction**". The built-in non-return valve maintains this state, depending on the porosity of the hoses and work piece, until the vacuum drops below the preset lower limit (hysteresis of the vacuum switch), when the function "**Suction**" is again activated until the vacuum reaches the upper limit value, when it is again switched off.

Disconnect the compressed air supply from **15** with the locally provided control valve.

- ⇒ The "**Blow off**" function is activated.

## 2.7 Einstellen des Abblasimpulses (nur SMP)

Die Geräte besitzen eine Stellschraube **13** zum Einstellen der Intensität des Abblasimpulses

## 2.7 Adjusting the Blow-Off Pulse (SMP only)

This unit has an adjusting screw **13** for adjustment of the blow-off pulse strength.

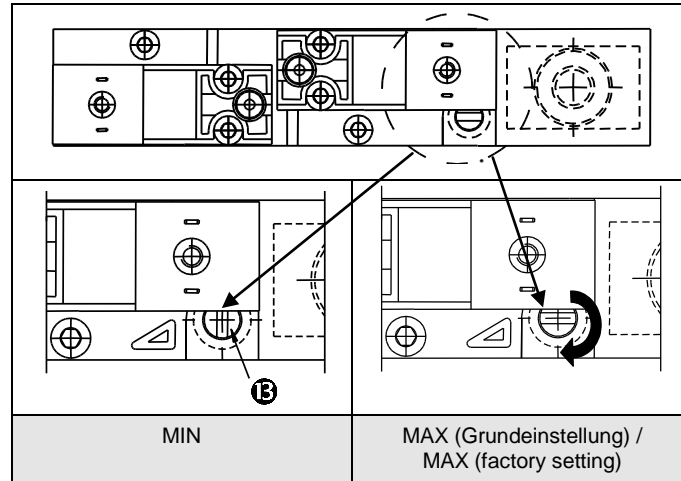

Über einen Einstellwinkel von 90° (ohne Festanschlag) kann die Intensität von **Min.** nach **Max.** (Lieferzustand) verändert werden, entsprechend schneller bzw. langsamer kann das vorher erzeugte Vakuum abgebaut werden. Diese Geräte besitzen auch eine **Zusatzfunktion**, die es ermöglicht, dass beim Abblasen der gesamte Druckluftvolumenstrom in den Saugkanal gepresst wird, was sich vor allem bei **langen** Saugleitungen hinsichtlich der Abblaszeit **positiv** auswirkt.

**Achtung!** Die Geräte der **SMP**-Baureihe dürfen nicht mit verschlossenem Vakuumanschluss **2** und kleineren als den angegebenen Schlauchinnendurchmesser (vakuumseitig (s.o.)) im Abblasmodus betrieben werden, was sonst zu unzulässigen Druckverhältnissen im System führen würde und die Beschädigung bzw. Zerstörung von Bauelementen nach sich ziehen könnte. Des Weiteren dürfen diese Geräte nicht zum Befüllen von Druckbehältern; zum Antrieb von Zylindern; Ventilen o.ä. druckbetriebenen Funktionselementen eingesetzt werden, was eine „**Nicht bestimmungsgemäße Verwendung**“ bedeuten würde.

## 3. Bedienung und Betrieb

**Achtung!** Im Transportbereich der Nutzlast, die mittels des vom Gerät erzeugten Vakuums angesaugt wurde, dürfen sich keine Personen unter der Nutzlast aufhalten. Bei Ausfall der elektrischen Energie verhindert ein eingebautes Rückschlagventil einen schnellen Abbau des Vakuums und damit ein plötzliches Lösen der Nutzlast. Leckagen in der Verschlauchung oder rauhe oder durchsaugende Oberflächen können trotzdem zum mehr oder weniger schnellen Abbau des Vakuums bei Energieausfall führen.

### 3.1 SMP/SCP... NO ...

Bitte beachten Sie, dass zum Erreichen des Zustandes „Abblasen“ **beide** Magnetventile **gleichzeitig** mit der Versorgungsspannung beaufschlagt werden müssen, um ein uneffizientes „Abblasen“ bei gleichzeitigem „Saugen“ zu verhindern.

### 3.2 SMP/SCP... NC ...

Versorgungsspannung für die Magnetventile immer im **Wechsel** anlegen, damit ein überschneidungsfreies „Saugen“ bzw. „Abblasen“ gewährleistet werden kann.

Turning the screw through 90° (it has no stops) varies the strength of the pulse from **Min.** to **Max.** (factory setting), and the previously generated vacuum is reduced more slowly or quickly. These units have an **additional function** which permits the volume of compressed air to be blown into the suction channel; this has a **positive** effect on the blow-off time, particularly if **long** suction hoses are being used.

**Caution!** The units of the **SMP** Series may not be operated in blow-off mode with the vacuum connector **2** closed and with hoses with less than the recommended internal diameter (see above) on the vacuum side, since this would result in unpermissible pressure conditions and could cause damage to, or destruction of, internal components. Furthermore, these units may not be used for filling pressure reservoirs or for driving pneumatic cylinders, valves or other pressure-operated functional elements. Their use for such purposes would constitute "**use for other than the intended purpose**".

## 3. Operation

**Caution!** no persons may enter the area below the suspended load which is held by the vacuum. In the case of failure of electricity, a built-in non-return valve prevents rapid loss of the vacuum and sudden release of the load. Nevertheless, leaks in the hoses or rough or porous surfaces on the load can cause the vacuum to drop more or less quickly if the power fails.

### 3.1 SMP/SCP... NO...

Please note that **both** solenoid valves must receive the supply voltage **simultaneously** in order to switch the unit to the "Blow off" state. Otherwise, blowing off will be less efficient, as the suction function will hinder blowing off.

### 3.2 SMP/SCP... NC...

The supply voltage must always be connected to **either one solenoid valve or the other** at any time in order to avoid simultaneous activation of the "Suction" and "Blow off" functions.

### 3.3 SMP/SCP... mit interner Regelung (Versionen ... RE/RD/RP)

Die Schaltheufigkeit und damit der Luftinspareffekt sind abhängig von der Oberfläche und der Dichtheit des anzusaugenden Werkstücke bzw. des zu evakuierenden Raumes. Bei sehr porösen Werkstücken kann es zu einer relativ hohen Schaltheufigkeit kommen, die nur unwesentlich zur Luftersparung beiträgt, dafür aber zu einer erhöhten Verschleißbeanspruchung des Gerätes führen kann.

Die Geräte werden mit einer Voreinstellung der Vakuumschalter und damit einer Voreinstellung des internen Regelbereiches ausgeliefert. Voreinstellwerte:

Version ... RD			Version ... RE		
Ausgang 1	Schaltfunktion	NO	Schaltpunkt S	750 mbar	Version ... RP
	Modus	Hysterese	Hysterese H	150 mbar	
	Schaltpunkt H	750 mbar	Schaltpunkt S	750 mbar	
	Hysterese h	150 mbar	Hysterese H	50 .. 100 mbar	
Ausgang 2	Schaltfunktion	NO	Schaltpunkt S	750 mbar	Version ... RP
	Modus	Hysterese	Hysterese H	50 .. 100 mbar	
	Schaltpunkt H	550 mbar	Schaltpunkt S	750 mbar	
	Hysterese h	10 mbar	Hysterese H	50 .. 100 mbar	

Bei einer Änderung des Regelbereiches ist darauf zu achten, dass die Hysterese nicht zu klein gewählt wird, was zu einer höheren Schaltheufigkeit führt bzw. nicht zu groß gewählt wird, was zu einer Minderung der Tragsicherheit führen kann, wenn z.B. der untere Einschaltpunkt der Regelung unterhalb des für die Systemauslegung mindestens erforderlichen Vakuumniveaus liegt.

#### 3.3.1 SMP/SCP... RD

Das Gerät liefert ein **digitales** Zusatzsignal zur Verarbeitung in einer externen Steuerung (z.B. SPS) welches als Überwachung des internen Regelkreises eingesetzt werden kann. Es ist unabhängig vom internen Regelkreis programmierbar.

Bei einer Änderung der Voreinstellung ist darauf zu achten, dass das Zusatzsignal als Überwachungsfunktion immer knapp unterhalb des unteren Einschaltpunktes des internen Regelkreises liegen sollte (Schaltpunkt "H" abzüglich Hysterese "h").

#### 3.3.2 SMP/SCP... RE

Das Gerät liefert ein **analoges** Zusatzsignal im Bereich von +1.....+5V, welches **nicht** unabhängig vom internen Regelkreis eingestellt werden kann. Die Höhe der ausgegebenen Spannung ist druckproportional dem eingestellten internen Regelbereich. Zu beachten ist, dass die Signalausgabe **nur** während der **Luftsparpausen** erfolgt.

#### 3.3.3 SMP/SCP... RP

Das Gerät liefert **kein** Zusatzsignal.

## 4. Wartung

### 4.1 Allgemein

Bei äußerer Verschmutzung mit weichem Lappen und Seifenlauge (max. 60° C) reinigen. Darauf achten, dass der Schalldämpfer **nicht** mit Seifenlauge getränkt wird!

### 4.2 Filter

Kontrollieren Sie regelmäßig den Verschmutzungsgrad des angebauten Vakuumfilters. Starke Verschmutzung führt zur Leistungsminderung (längere Ansaugzeiten; niedrigeres Vakuum). Bei starker Verschmutzung sollte der Filter gereinigt bzw. ausgetauscht werden. Entfernen Sie dazu die Befestigungsschrauben am Filtergehäuse **4**. Entnehmen Sie den Filtereinsatz **5** - trockene Stäube können von **innen nach außen** ausgeblasen werden, bei feuchtem oder öligem Schmutz ist nur ein Austausch empfehlenswert.

Das Filtergehäuse selbst darf **nur mit Seifenlauge** (max. 60° C) gereinigt werden. Die Formdichtung am Filtergehäuse kann mit **Seifenlauge** oder **Waschbenzin** gereinigt werden.

**Achtung:** Bei Montage des Filtergehäuses nach Reinigung

- ⇒ Einlegen der Dichtung nicht vergessen!
- ⇒ Alle Schrauben einsetzen und gleichmäßig anziehen!
- ⇒ Drehmoment der Befestigungsschrauben für das Filtergehäuse: 0,8 Nm.
- ⇒ Das Filtergehäuse darf nicht mit Cyancrylatkleber in Kontakt kommen.

### 4.3 Schalldämpfer

Der Schalldämpfer **6** kann im Laufe der Zeit mit Staub, Öl usw. verschmutzt werden, so dass sich die Saugleistung verringert. Er sollte dann ausgetauscht werden. Eine Reinigung ist auf Grund der Kapillarwirkung des porösen Materials nicht empfehlenswert.

### 3.3 SMP/SCP... mit interner Regelung (Version ... RE/RD/RP)

The switching frequency, and thus the air-saving effect, depends on the surface of the load and is air-tightness or on the volume to be evacuated. Very porous work pieces can result in relatively high switching frequencies; these save little air but cause increased wear on the unit.

The vacuum switch, and thus the regulation range, is set in the factory to the following values:

Version ... RD			Version ... RE		
Output 1	Switch function	NO	Switching point S	750 mbar	Version ... RP
	Mode	Hysteresis	Hysterese H	150 mbar	
	Switching point H	750 mbar	Switching point S	750 mbar	
	Hysteresis h	150 mbar	Hysterese H	50 .. 100 mbar	
Output 2	Switch function	NO	Switching point S	750 mbar	Version ... RP
	Mode	Hysteresis	Hysterese H	50 .. 100 mbar	
	Switching point H	550 mbar	Switching point S	750 mbar	
	Hysteresis h	10 mbar	Hysterese H	50 .. 100 mbar	

If these settings are changed, care must be taken that the hysteresis is not made too small, since this can cause increased switching frequencies, or too large, since this can reduce the safety function if, for example, the lower limit of the range lies below the minimum vacuum level required on which the system design is based.

#### 3.3.1 SMP/SCP... RD

These units deliver an additional **digital** signal for use in an external controller (such as a PLC). This can be used for monitoring the internal control loop. The signal can be programmed **independently** of the internal control loop.

If the default setting is changed, it should be noted that this signal, if used for monitoring, should be generated just below the point at which the internal control loop switches on the vacuum generator (switching point "H" – the hysteresis "h").

#### 3.3.2 SMP/SCP... RE

These units deliver an additional **analogue** signal in the range +1...+5 V which is **not** independent of the internal control loop. The output voltage is proportional by pressure to the internal control loop setting. Note that this signal is output **only** when the vacuum generator is switched off.

#### 3.3.3 SMP/SCP... RP

This unit **does not** deliver an additional signal.

## 4. Maintenance

### 4.1 Introduction

Clean the outside of the unit as necessary with a soft cloth and soap solution (max. 60° C). Take care that the silencer does not become saturated with soap solution!

### 4.2 Filter

Check the contamination level of the vacuum filter at regular intervals. Excessive dirt in the filter reduces the performance (longer suction times, lower vacuum). The filter should be cleaned or replaced when it is dirty. To do this, remove the securing screws from the filter housing **4** and take out the filter insert **5**. Dry dust can be blown out with compressed air **from the inside outwards**. If the dirt is damp or oily, we recommend replacing the filter insert.

The filter housing may be cleaned **only with soap solution** (max. 60° C). The shaped gasket in the filter housing may be cleaned with **soap solution or benzene**.

**Caution:** when mounting the filter housing after cleaning:

- ⇒ remember to fit the gasket!
- ⇒ insert all screws and tighten them equally!
- ⇒ Tightening torque for the securing screws of the filter housing: 0.8 Nm
- ⇒ Do not allow the filter housing to come into contact with cyanoacrylate adhesives.

### 4.3 Silencer

The silencer **6** can become filled with dust, oil, etc. in the course of time. This will cause the suction capacity to be reduced. When this occurs, the silencer should be replaced, since the capillary effect of the porous material used in it makes cleaning difficult or even impossible.

## 5. Zubehör

### Stecker für Magnetventile

Steckertyp	Für SCP 10 / 15
Stecker mit 3 m Kabel	21.04.06.00086

Steckertyp für	SMP / SCP 20...30
Stecker mit Schutzbeschaltung und 5 m Kabel	21.04.06.00084
Stecker mit Schutzbeschaltung ohne Kabel	21.04.06.00085

### Stecker für Vakuum-Schalter

Steckertyp	Art.No.
Stecker; gerade mit 5 m Kabel	10.06.02.00031
Stecker; 90° mit 5 m Kabel	10.06.02.00032

### Staubfilter

Bei starkem Schmutzanfall saugseitig oder feinem Staub <50 µm ist ein separater Staubfilter dem Gerät vorzuschalten

Filtertyp	Art.No.	Geeignet für Ejektor
F 1/4	10.07.01.00003	SMP / SCP 10-15 ...
F3/8	10.07.01.00004	SMP / SCP 20 ...
STF 3/4	10.07.01.00007	SMP / SCP 25-30 ...

## 6. Fehlersuche

Störung	mögliche Ursache	Abhilfe
Vakuumniveau wird nicht erreicht oder Vakuum wird zu langsam aufgebaut	Filter verschmutzt	Filter reinigen bzw. austauschen
	Schalldämpfer verschmutzt	Schalldämpfer austauschen
	Leckage in Schlauchleitung	Schlauchverbindungen überprüfen
	Leckage am Sauggreifer	Sauggreifer überprüfen
	Betriebsdruck zu gering	Betriebsdruck erhöhen (siehe Kennlinien)
	Innen-Ø der Schlauchleitungen zu klein	Siehe Empfehlungen für Schlauch-Ø
Nutzlast kann nicht festgehalten werden	Vakuumniveau zu gering	Bei Luftsparschaltung erhöhen Sie den Regelbereich
	Sauggreifer zu klein	Größeren Sauggreifer auswählen
Interner Regelkreis schaltet nicht ab	Schaltpunkt höher als max. mögliches Vakuum eingestellt	Schaltpunkt zurücksetzen
Interner Regelkreis schaltet nicht ein	Hysterese größer als Schaltpunkt	Hysterese verkleinern oder Schaltpunkt vergrößern
Regelung funktioniert nicht	Kabel am Elektromagnetventil vertauscht	Kabel richtig anschließen (siehe Pkt. 2.2)

## 5. Accessories

### Plugs for solenoid valves

Plug type	for SCP 10 / 15
Plug with 3 m cable	21.04.06.00086

Plug type for	SMP / SCP 20...30
Plug with protective circuit and 5 m cable	21.04.06.00084
Plug with protective circuit, without cable	21.04.06.00085

### Plugs for vacuum switches

Plug type	Article No.
Plug, straight, with 5 m cable	10.06.02.00031
Plug; 90° with 5 m cable	10.06.02.00032

### Dust filters

In very dusty operating conditions, or in the case of fine dust <50 µm, a separate dust filter must be fitted on the inlet side.

Filter type	Article No.	Suitable for ejector
F 1/4	10.07.01.00003	SMP / SCP 10-15 ...
F3/8	10.07.01.00004	SMP / SCP 20 ...
STF 3/4	10.07.01.00007	SMP / SCP 25-30 ...

## 6. Fault-Finding

Symptom	Possible cause	Remedy
Vacuum to low or vacuum generation takes too long	Filter dirty	Clean or replace filter
	Silencer dirty	Replace silencer
	Leaks in hoses	Check hose connectors
	Leaks on suction pad	Check suction pads
	Operating pressure too low	Increase the pressure (see technical data)
Load cannot be held	Internal diameter of hoses too small	See recommended hose diameters
	Vacuum too low	If air-saving is used, increase the hysteresis
	Suction pad too small	Use a larger suction pad
Internal control loop does not switch vacuum generator off	Switching point higher than the maximum possible vacuum	Reduce the upper limit value
Internal control loop does not switch vacuum generator on	Hysteresis greater than switching point	Reduce the hysteresis or increase the switching point
Regulation does not work	Cables connected to wrong solenoid valves	Connect cables to correct valves (see Chapter 2.2)

## 7. Ersatz- und Verschleißteile / Spare and consumable parts

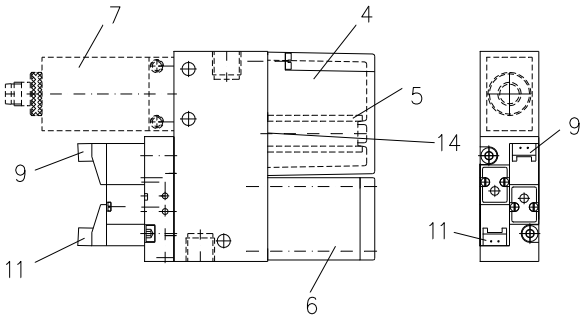
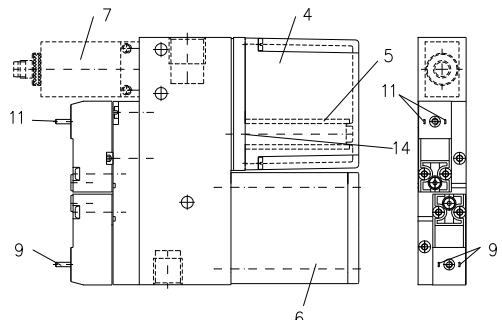
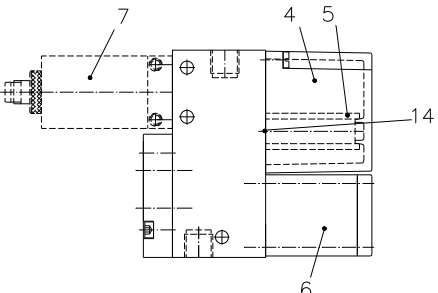
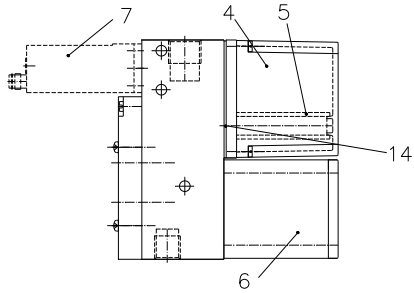
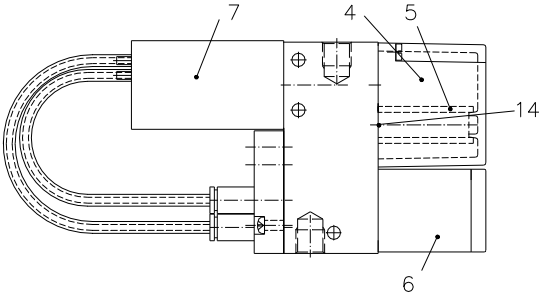
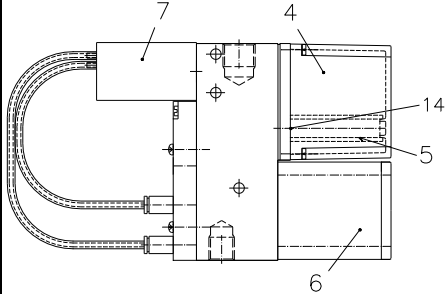
Ejector SCP 10 - 15 (auch geregelte Version ...RD/RE / also regulated version ...RD/RE)	Ejectors SMP 15 - 30 and SCP 20 - 30 (auch geregelte Version ...RD/RE / also regulated version ...RD/RE)
	
Ejector SCP 10 - 15 ...FS (mit Fremdsteuerung / with external control)	Ejectors SMP 15 - 30 ... / SCP 20 - 30 (mit Fremdsteuerung / with external control)
	
Ejector SCP 10 - 15 ...FS-RP (mit Fremdsteuerung, pneumatisch geregelt / with external control, pneumatically regulated)	Ejectors SMP 15 - 30 ... / SCP 20 - 30 ... FS-RP (mit Fremdsteuerung, pneumatisch geregelt / with external control, pneumatically regulated)
	

Pos.	Stk.	Benennung	Designation	Gerät / Unit	Art.-No.	Anzugsmoment beachten / Note torque	Legend e
4	1	Filtergehäuse kpl.	Filter housing cpl.	SCP 10-15	10.02.02.00809	0,8 Nm	VB
	1	Filtergehäuse kpl.	Filter housing cpl.	SMP / SCP 20-30...	10.02.02.00808	0,8 Nm	VB
5	1	Filterelement	Filter element	SCP 10-15	10.02.02.00655		V
	1	Filterelement	Filter element	SMP / SCP 20-30	10.02.02.00654		V
6	1	Schalldämpfer	Silencer	SCP 10-15	10.02.02.00653		V
	1	Schalldämpfer	Silencer	SMP 15-20 / SCP 20...	10.02.02.00651		V
	1	Schalldämpfer	Silencer	SMP 25-30 / SCP 25-30...	10.02.02.00652		V
	1	Schalldämpfer geschlitzt	Silencer with slit	SMP 25-30 / SCP 25-30...	10.02.02.01318		V
	1	Schalldämpfer geschlitzt	Silencer with slit	SCP 10-15	10.02.02.01497		V
	1	Schalldämpfer geschlitzt	Silencer with slit	SMP 15-20 / SCP 20	10.02.02.01533		V
7	1	VS-V-A-EM-M8-kpl	VS-V-A-EM-M8-kpl	SMP/SCP...VM	10.06.02.00095	1 Nm	E
	1	VS-V-A-PNP-S-M8-kpl	VS-V-A-PNP-S-M8-kpl	SMP/SCP...VE	10.06.02.00096	1,4 Nm	E
	1	VS-V-PNP	VS-V-PNP	SMP/SCP...VEH/RE	10.06.02.00027	0,8 Nm	E
	1	VS-V-D-PNP	VS-V-D-PNP	SMP/SCP...VD/RD	10.06.02.00049	1 Nm	E
	1	VS-V-PM-NC	VS-V-PM-NC	SMP/SCP...FS	10.06.02.00118	1 Nm	E
				SMP/SCP...FS RP-NO	10.06.02.00118	1 Nm	E
	1	VS-V-PM-NO	VS-V-PM-NO	SMP/SCP...FS	10.06.02.00117	1 Nm	E
9	1	Elektromagnetventil (1)*	Solenoid valve (1)*	SCP 10-15 NO...	10.05.01.00195	0,2 Nm	E
	1	Elektromagnetventil (1)*	Solenoid valve (1)*	SCP 10-15 NC...	10.05.01.00196	0,2 Nm	E
	1	Elektromagnetventil (1)*	Solenoid valve (1)*	SMP/SCP 20-30 NO...	10.05.01.00107	0,8 Nm	E
	1	Elektromagnetventil (1)*	Solenoid valve (1)*	SMP/SCP 20-30 NC...	10.05.01.00106	0,8 Nm	E
11	1	Elektromagnetventil (2)*	Solenoid valve (2)*	SCP 10-15 NO/NC...	10.05.01.00196	0,2 Nm	E
	1	Elektromagnetventil (2)*	Solenoid valve (2)*	SMP/SCP 20-30 NO/NC...	10.05.01.00106	0,8 Nm	E
14	1	Rückschlagventil	Check valve	SCP 10-15	10.02.02.01665		E
	1	Rückschlagventil	Check valve	SCP 20-30 / SMP 15-30...FS	10.02.02.01295		E

\*Funktion des Ventils / Functions of the valve: (1) Funktion „Saugen“ / Function „Suction“ (2) Funktion „Abblasen“ / Function „Blow-Off“

E= Ersatzteil, V= Verschleißteil, VB= Verschleißteilbaugruppe, enthält Verschleißteile

E= Spare part, V= Consumable part, VB= Consumable-part assembly, contains consumable parts

## 8. Pneumatikschaltpläne SCP / Pneumatic Circuit Diagrams SCP

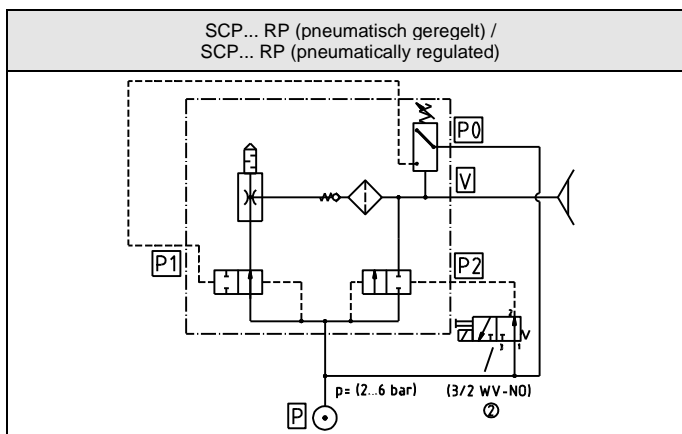
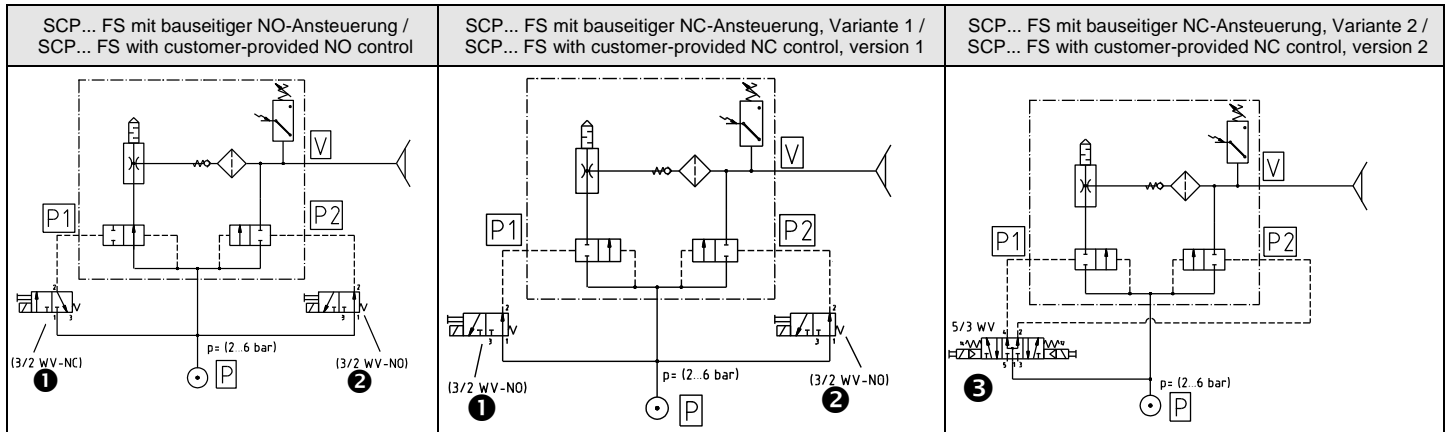
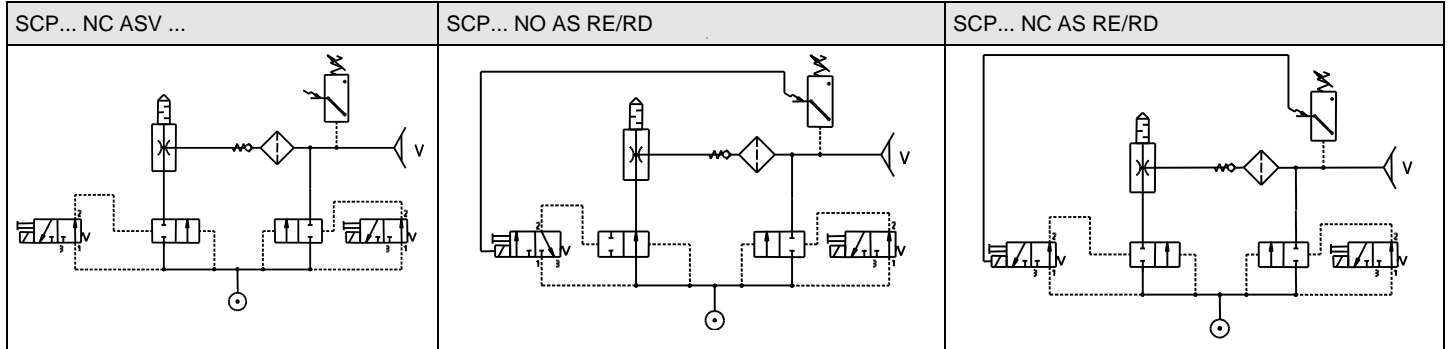
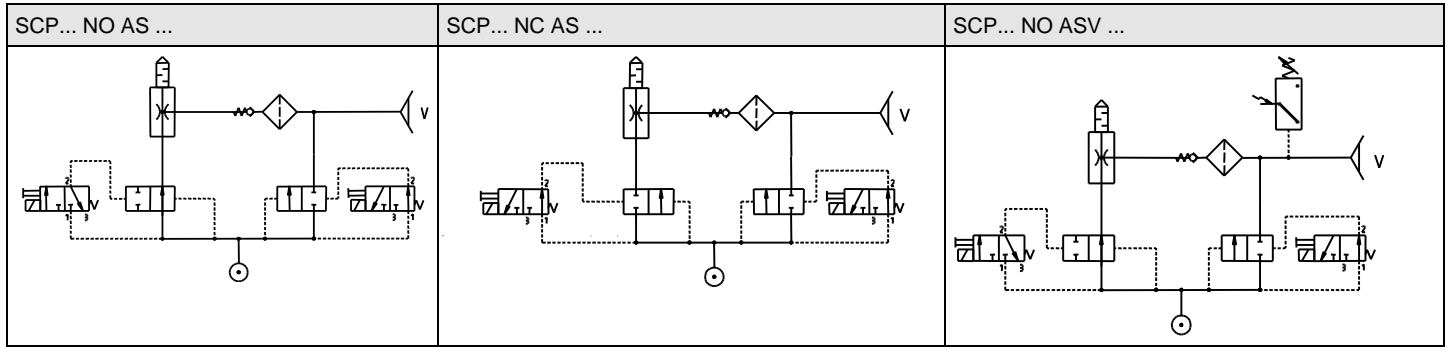

- ❶ externes Steuerventil „Saugen“ (bauseits) /  
external control valve (provided by customer)
- ❷ externes Steuerventil „Abblasen“ (bauseits) /  
external control valve „Blow off“ (provided by customer)
- ❸ externes Steuerventil (bauseits), Grundstellung belüftet /  
external control valve „Blow off“ (provided by customer), idle  
position vented

## 9. Pneumatikschaltpläne SMP / Pneumatic Circuit Diagrams SMP

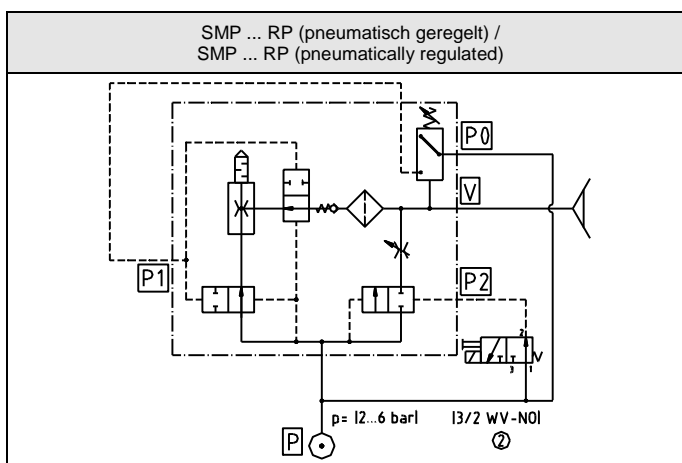
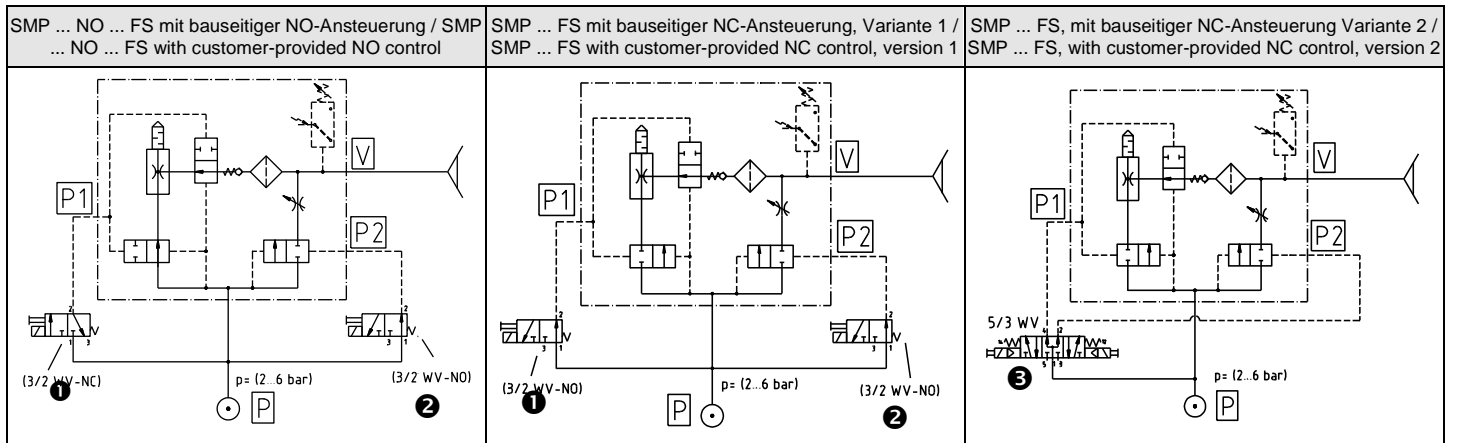
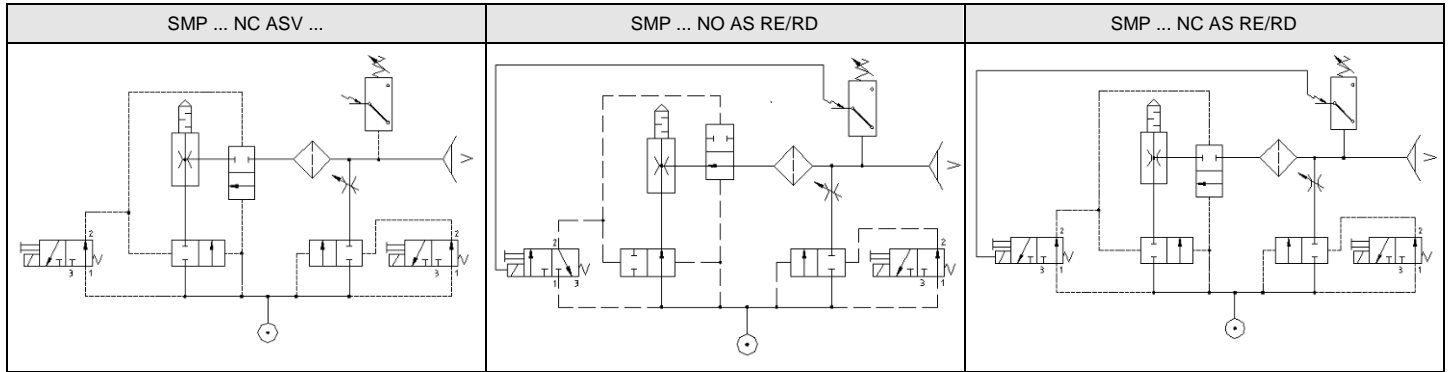
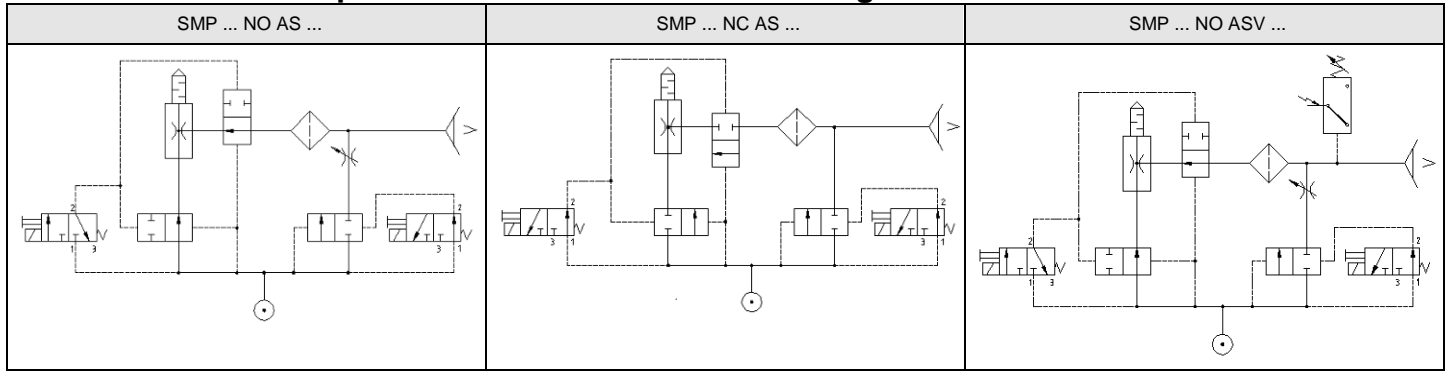

- ❶ externes Steuerventil „Saugen“ (bauseits) / external control valve (provided by customer)
- ❷ externes Steuerventil „Abblasen“ (bauseits) / external control valve „Blow off“ (provided by customer)
- ❸ externes Steuerventil (bauseits), Grundstellung belüftet / external control valve „Blow off“ (provided by customer), idle position vented



## 10. Benutzer- und Sicherheitsanweisungen

Unzulässiger Betrieb mit anderen Medien kann zu Funktionsstörungen, Schäden und Verletzungen – auch Lebensgefahr – führen.

### Montage / Demontage

#### Nur im spannungslosem und drucklosem Zustand zulässig !

Die Bauteile dürfen nur von zuverlässigem Fachpersonal eingesetzt werden, das unter anderem geschult und vertraut ist mit:

- ⇒ den neuesten geltenden Sicherheitsregeln und Anforderungen beim Einsatz der Bauteile und deren Steuerungen in Geräten, Maschinen und Anlagen (für Magnetventile, Druckschalter, elektronischen Steuerungen etc.)
- ⇒ und deren erforderlicher elektrischer Ansteuerung, z.B. Redundanzen und ggf. Rückmeldungen (für Elektromagnetventile, Druckschalter, elektronischen Steuerungen etc.)
- ⇒ und dem sachgerechtem Umgang mit Bauteilen und Produkten für deren Zweckbestimmung
- ⇒ und deren sachgerechtem Einsatz mit dem Betriebsmedium
- ⇒ und den jeweils erforderlichen, neuesten geltenden EG-Richtlinien, Gesetzen, Verordnungen und Normen
- ⇒ und den jeweils neuesten Stand der Technik.

**Der unsachgemäße Betrieb der Bauteile**, u.a. mit anderen als den zulässigen Betriebsmedien, angegebenen Spannung und zulässigen Umweltbedingungen kann zu Funktionsstörungen, Schäden, Verletzungen führen.

Diese Aufstellung soll Hilfestellung geben und erhebt keinen Anspruch auf Vollständigkeit. Sie ist bedarfsweise durch den Anwender zu ergänzen.

### Sicherheitshinweise

Für sichere Installation und störungsfreien Betrieb sind weiterhin u.a. folgende Verhaltensweisen nebeneinander zu beachten und einzuhalten:

- ⇒ die Bauteile sind den Verpackungen sorgfältig zu entnehmen.
- ⇒ Die Bauteile sind generell vor Beschädigungen jeglicher Art zu schützen
- ⇒ **Bei Installation und Wartung: Bauteil, Gerät spannungs- und druckfrei schalten und gegen unbefugtes Wiedereinschalten sichern.**
- ⇒ **Betrieb des Gerätes ausschließlich über Netzgeräte mit Schutzkleinspannung (PELV) und sicherer elektrischer Trennung der Betriebsspannung, gemäß EN60204.**
- ⇒ Es dürfen keine Veränderungen an den Bauteilen vorgenommen werden.
- ⇒ Sauberkeit im Umfeld und am Einsatzort
- ⇒ Anschlusssymbole und -bezeichnungen befinden sich auf den Bauteilen und sind entsprechend zu beachten
- ⇒ Nur die vorgesehenen Anschlussmöglichkeiten sind zu benutzen.
- ⇒ Zur Installation sind nur für den Einsatz des Betriebsmediums geeignete Armaturen und Schläuche / Rohre fachgerecht einzusetzen (**sich lösende Schläuche oder elektrische Anschlussleitungen bedeuten extrem großes Unfallrisiko – auch Lebensgefahr!**)
- ⇒ Spannungs- und stromführende Leitungen müssen über ausreichende Isolierung und Leitungsquerschnitte verfügen und sind fachgerecht zu installieren
- ⇒ Pneumatische und elektrische Leitungsverbindungen müssen dauerhaft mit dem Bauteil verbunden und gesichert sein.
- ⇒ Für ausreichenden Berührungsschutz der elektrischen Anschlüsse und installierten Bauteile sorgen.
- ⇒ Nur die vorgesehenen Befestigungsbohrungen bzw. Befestigungsmittel benutzen
- ⇒ Es sind stets alle für den Verwendungszweck erforderlichen neuesten und gültigen Richtlinien, Gesetze, Verordnungen, Normen und der neuste Stand der Technik einzuhalten.
- ⇒ Erforderlichenfalls sind pagens des Anwenders besondere Maßnahmen zu ergreifen, um Forderungen einzuhalten Richtlinien, Gesetze, Verordnungen, Normen und den neuesten Stand der Technik zu erfüllen.

Nichtbeachtung dieser vorgenannten Verhaltensweisen kann zu Funktionsstörungen, Schäden und Verletzungen –auch Lebensgefahr– führen.

Die Bauteile sind bei Außerbetriebstellung des Gerätes umweltgerecht zu entsorgen!

### Hinweis zur elektromagnetischen Verträglichkeit

Physikalisch bedingt weist jeder Elektromagnet, jedes Magnetventil und Relais eine Spule auf, die eine Induktivität darstellt. Bei elektrischem Abschalten einer Induktivität ergibt sich durch das abbaubende Magnetfeld zwangsläufig ein Überspannungsimpuls, der in seinem Umfeld eine elektromagnetische Störung verursachen kann. Störende Impulse lassen sich bei diesen Bauteilen nur anwenderseits durch entsprechende Dämpfungsglieder unterdrücken. Hierzu zählen Z-Dioden und Varistoren.

## 10. Safety instructions for operation and maintenance

Operation with other than the specified media can result in incorrect function, damage to the components and (possibly fatal) injuries to persons.

### Assembly and disassembly

**This may be done only with the electrical and compressed-air supplies switched off!**

The components may be installed only by reliable and trained persons who have been instructed in and are familiar with:

- ⇒ the current safety regulations and the requirements for the use of the components and their controllers in devices, machines and plants (applies to solenoid valves, pressure switches, electronic controllers, etc.);
- ⇒ the necessary electrical controls such as redundancy and, if applicable, feedback signals (applies to solenoid valves, pressure switches, electronic controllers, etc.);
- ⇒ the correct handling of components and products for the intended purpose;
- ⇒ the correct use of the components with the operating medium being used;
- ⇒ the current editions of the applicable EU guidelines, laws and standards;
- ⇒ and the state of the art.

**Incorrect use of the components**, such as their with other than the specified operating media, specified voltages and permissible ambient conditions, can result in incorrect function, damage to equipment and injuries to persons.

This information is intended as an aid and is not necessarily complete. If necessary, it must be supplemented by the company operating the equipment.

### Safety notes

For safe installation and trouble-free operation, the following instructions must be observed and complied with:

- ⇒ Remove the components carefully from their packing materials.
- ⇒ Handle the components carefully to avoid damaging them.
- ⇒ **For installation and maintenance, switch off the electrical and compressed-air supplies to the component or equipment and ensure that they cannot be switched on inadvertently.**
- ⇒ **The unit may only be run via power supply units with protected extra-low voltage and safe electrical cut-off of the operating voltage, in accordance with EN60204.**
- ⇒ The components may not be modified in any manner.
- ⇒ Keep the components and the work area clean.
- ⇒ The connections are clearly marked on the components and must be connected accordingly.
- ⇒ Only the connection facilities provided may be used.
- ⇒ Only fittings and pipes/hoses suitable for the operating medium being used may be used for installation and must be connected correctly (**hoses or power cables which are not securely connected are a major cause of accidents, which may even result in fatal injuries to persons in the vicinity!**).
- ⇒ Electric cables must be suitably insulated and have a cross-section suitable for the current they are to carry. They must be installed securely and correctly.
- ⇒ Pneumatic pipes/hoses and electric cables must be permanently connected to the component and secured to prevent them from becoming loose.
- ⇒ All electrical terminals and components must be suitably covered to prevent accidental contact.
- ⇒ Only the mounting holes and brackets provided may be used for mounting the components.
- ⇒ All applicable regulations, guidelines, laws and standards must be observed at all times. All work must comply with the state of the art.
- ⇒ If necessary, the company operating the equipment must implement additional measures to ensure compliance with the applicable regulations, guidelines, laws and standards.

Non-compliance with the above can result in incorrect function, damage to equipment and (possible fatal) injuries to persons.

Any components removed from the equipment must be disposed of in accordance with the local environmental regulations.

### Note on electromagnetic compatibility (EMC)

Every electromagnetic, solenoid valve and relay contains a coil, which acts as an electrical inductance. When the current through such an inductance is switched off, the decaying magnetic field generates an over voltage pulse which can cause electromagnetic disturbances in the vicinity. Such pulses can be suppressed only locally by the connection of suitable damping components, such as Zener diodes or varistors.



**Hersteller / Manufacturer / Fabricant / Fabricante / Produttore**

J. Schmalz GmbH  
Aacher Str. 29  
D- 72293 Glatten

**Produktbezeichnung / Product name / Designation du produit /  
Denominación del producto / Denominazione del prodotto**

Ejektoren der Serie / Ejectors Series / Ejecteurs de la série / Eyectores de la serie / Eiettori della serie **SCP / SMP / SCPM**

**EG-Richtlinien / EU Directives / Directives CE / Normas CE / Direttive CE**

98 / 37 / EWG                      Maschinenrichtlinie / EC Machinery Directives / Directives pour machines /  
Normativa sobre maquinaria / Direttive per le macchine

89 / 336 / EWG                    Elektromagnetische Verträglichkeit / Electromagnetic compatibility / Compatibilité électromagnétique /  
Compatibilidad electromagnética / Compatibilità elettromagnetica

Für die Versionen mit Vakuumschalter und Elektromagnetventilen mit einer Betriebsspannung größer 50 V ist zusätzlich gültig:

For versions with vacuum switch and solenoid valve with a rated voltage greater than 50 V are in addition valid:

Pour les versions avec interrupteur pour le vide et des électrovannes pour une tension de service plus élevée que 50 volt, le suivant est valable en plus:

En las versiones de fabricación con interruptores de vacío y válvulas electromagnéticas con tensiones de alimentación superiores a 50 V, es de aplicación también la norma:

Per le versioni con interruttore di vuoto e valvole elettromagnetiche con tensione di esercizio superiore a 50 V, viene inoltre applicata la norma:

73 / 23 / EWG                      EG-Niederspannungsrichtlinie / EC low voltage standard / CE Directive Basse Tension /  
EC Reglamento de baja tensión / Direttive CE per la bassa tensione

**Harmonisierte Normen / Harmonized normes / Normes harmonisées /  
Normas armonizadas / Norme armonizzate**

EN 61000-6-3 / 08.2002            Elektromagnetische Verträglichkeit – Störaussendung / Electromagnetic compatibility – emission /  
Compatibilité électromagnétique – émission / Compatibilidad electromagnética – inmisiones /  
Compatibilità elettromagnetica - emissione di disturbi

EN 61000-6-2 / 08.2002            Elektromagnetische Verträglichkeit – Störfestigkeit / Electromagnetic compatibility – immunity /  
Compatibilité électromagnétique – immunité / Compatibilidad electromagnética – emisiones /  
Compatibilità elettromagnetica - immunità

**Unterschrift, Angaben zum Unterzeichner / Signature, details of signatory /**

**Signature, indications sur le soussigné / Firma y datos del firmante / Firma, dati concernenti il firmatario**

Glatten, 22.06.2006 

Name und Funktion des Unterzeichners / Name and function of the signatory /

Nom et fonction du soussigné / Nombre y función del firmante / Nome e funzione del firmatario

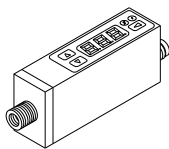

# Operation instructions vacuum switch • pressure switch

## VS-D Series

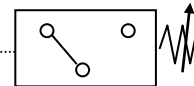

### Operation instructions vacuum switch

#### 1. Front panel

LED Output 1  
LED Output 2  
Up  
Down  
Mode  
Display

Display:  
Preset values in setting mode.  
Vacuum level in measurement mode.

The minus sign is not displayed when pressure unit bar, inHg or mmHg is selected (VS-V-D).

Mode	Button to select the different modes.
Up & Down	Buttons to change settings.
LED Output 1 and Output 2	Switching indicator, Output 1 = red, Output 2 = green.

#### 2. Connecting power supply in normal operation

After connecting the power supply, in the display panel you can see the preset values.

When connecting the power supply do not push any key.

Type Selected pressure unit Display Measured pressure

#### 3. Zero-point adjustment

Adjust the zero-point only when the vacuum/pressure line is not connected. To adjust the zero-point, push the "Mode"-key at least 3 seconds.

Display Measured  $P_{atm}$  Hold for min. 3 sec Zero-point adjusted

#### 4. Clear All

If the switch was wrongly programmed, it can be set back in to the factory settings.

All stored values are cleared. To accomplish this function, disconnect the switch from the power supply. Whilst pushing the "Mode"-key and the "Up"-key, connect the power supply again.



Push and hold both keys simultaneously

After connecting the power supply, the display shows "CLA". When you release the buttons, the presetted pressure unit is displayed by "-bA" resp. "bA".

When pushing the "Mode"-key one time, the selected pressure unit is confirmed and stored.

1x

To adjust another pressure unit see paragraph 6.3

#### 5. Factory settings

The switch is delivered with following factory settings

Unit	Output 1	Output 2
bar	HYS, N.O.	HYS, N.O.

This setting can be changed (programmed). The programming is described in the following paragraph.

A built-in EEPROM retains data for a period of min. 10 years. The data are min. 10.000 times rewritable.

N.O. = normally open, N.C. = normal closed,

HYS = operating mode „Hysteresis mode“

The initial settings of the operating mode is shown in the table in paragraph 8.

#### 6. Setting of output configuration (N.O. or N.C.) and pressure unit (e.g. bar).

To adjust the output configuration and the pressure unit, push and hold the "Mode"-key, then push the "Up"-key.

hold

The display is alternating between "ou 1" and "n.o."

#### 6.1 Selection N.O. or N.C. of output 1

To change the setting, push "Up"- or "Down"-key.

Store the settings with the "Mode"-key.

1x

Now the display switches to the selection of output 2, the display changes from "ou 2" to "n.o."

#### 6.2 Selection N.O. or N.C. of output 2

To change the setting, push "Up"- or "Down"-key.

Store the settings with the "Mode"-key.

1x

Now the display switches to the selection of the pressure unit.

#### 6.3 Adjust the pressure unit

To change the setting, push "Up"- or "Down"-key.

Store the settings with the "Mode"-key.

1x

#### Possible pressure units for VS-V-D

Unit	bar	mmHg	inHg	kPa
Symbol	-bA	-H9	-iH	-PA

#### Possible pressure units for VS-P10-D

Unit	psi	kgf/cm <sup>2</sup>	MPa	bar
Symbol	P5	F9	PA	bA

#### 7. Adjusting the operating mode

##### 7.1 Adjusting output 1

Example: Switch VS-V-D, output 1 has the operating mode "Hysteresis-mode".

switching point: -0,6 bar  
hysteresis: 0,15 bar

Further information to the modes see paragraph 8.

Adjusting the operating mode

To select output 1, push "Mode"-key 2x.

2x wait 2 sec

After 2 seconds, the display is alternating between "ou 1" and the preadjusted operating mode.

Push the "Up"- or "Down"-key until "HYS" for the desired switching mode „Hysteresis-mode“ is displayed.

Store the settings with the "Mode"-key.

1x

#### Setting switching point and hysteresis

To select the switching point of output 1 push "Mode"-key 1x.

1x wait 2 sec

After 2 seconds, the display is alternating between "H-1" and the preadjusted value.

To adjust the switching point, push the "Up"- or "Down"-key until the desired value is displayed.

Store the settings with the "Mode"-key.

1x

Now the display switches to the selection of the hysteresis. The display is alternating between "h-1" and the preadjusted value.

To adjust the hysteresis, push the "Up"- or "Down"-key until the desired value is displayed.

Store the settings with the "Mode"-key.

1x

#### 7.2 Adjusting output 2

Example: Switch VS-V-D, output 2 has the operating mode "Window comparator mode"

Switching points are between -0,57 bar and -0,83 bar (lower margin A=-0,57, upper margin b = -0,83)

Further information to the modes see paragraph 8.

#### Adjusting the operating mode

To select output 2, push "Mode"-key 4x

4x wait 2 sec

After 2 seconds, the display is alternating between "ou 2" and "HYS".

Push the "Up"- or "Down"-key until "CnP" for the desired switching mode "Window Comparator Mode" is displayed.

Store the settings with the "Mode"-key.

1x

Adjusting the lower and the upper margin

To select the lower margin of output 2, push "Mode"-key 3x

3x wait 2 sec

After 2 seconds, the display is alternating between "A-2" and the preadjusted value.

Push the "Up"- or "Down"-key until the desired value is displayed.

Store the settings with the "Mode"-key.

1x

Now the display switches to the adjustment of the upper margin. The display is alternating between "b-2" and the preadjusted value.

To adjust the upper margin, push "Up"- or "Down"-key.

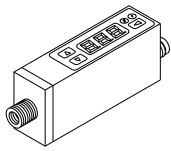

# Operation instructions vacuum switch • pressure switch

# VS-D Series

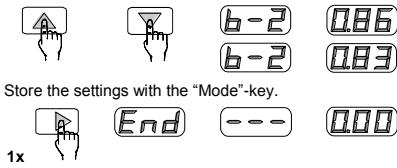
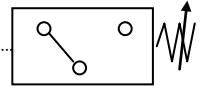

Store the settings with the "Mode"-key.

1x

## 8. Operating modes of the outputs

The outputs can be operated in two different modes. Each output can be adjusted independent of the other. The modes are described in the following.

### 8.1 Hysteresis mode

Settings are switching point H and hysteresis h.

Example: VS-V-D

H = -0.60 bar

h = 0.15 bar

N.O. (Normally Open)

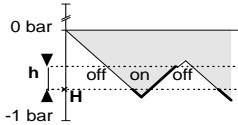

At 0 bar, the digital output is off.

When the vacuum level increases up to the **switching point H**, the digital output switches on. As long as the vacuum is higher than -0.45 bar (= 0.6 bar - 0.15 bar), the digital output stays on. When the vacuum decreases and passes -0.45 bar, the digital output switches off.

For the configuration of N.C. (Normally Closed), the output switches reverse (off > H, on < H-h).

Factory setting: Output 1 & 2 in Hysteresis mode

VS-V-D	mmHg	inHg	kPa	bar
H - 1	345	13.6	-46	0.46
h - 1	50	2.0	-7	0.07
H - 2	595	23.4	-79	0.79
h - 2	50	2.0	-7	0.07

VS-P10-D	psi	kgf/cm <sup>2</sup>	MPa	bar
H - 1	67	4.75	0.46	4.6
h - 1	10	0.70	0.07	0.7
H - 2	115	8.2	0.79	7.9
h - 2	10	0.7	0.07	0.7

### 8.2 Window Comparator mode

Settings are lower margin A and upper margin b.

Example: VS-V-D

A = -0.45 bar

b = -0.60 bar

N.O. (Normally Open)

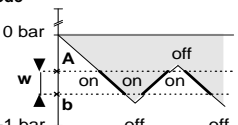

At 0 bar, the digital output is off.

When the vacuum level increases up to the **lower margin A**, the digital output switches on. As long as the vacuum level is in the "window" between the **lower margin A** and the **upper margin b**, the digital output stays on.

When the vacuum level becomes higher than the **upper margin b**, the digital output switches off.

For the configuration of N.C. (Normally Closed), the output switches reverse (A < off < b, A < on > b).

Factory setting: Output 1 & 2 in Window Comparator mode

VS-V-D	mmHg	inHg	kPa	bar
A - 1	195	7.6	-26	0.26
b - 1	400	15.6	-53	0.53
A - 2	495	19.4	-66	0.66
b - 2	645	25.4	-86	0.86

VS-P10-D	psi	kgf/cm <sup>2</sup>	MPa	bar
A - 1	38	2.7	0.26	2.6
b - 1	77	5.5	0.53	5.3
A - 2	96	6.85	0.66	6.6
b - 2	125	8.90	0.86	8.6

## 9. Display of Peak and Bottom values

The built-in memory stores in normal operation the peak value and bottom value since the switch was connected to the power supply. These will be displayed as follow:

To display the peak value, push the "Up"-key



1x

To display the bottom value, push the "Down"-key



1x

## 10. Rotate display

If the mounting position is twisted (rotated on head), the display can be rotated. When connecting the power supply, push and hold the buttons "Up" and "Down".

Note that the decimal point lights up now at the upper margin of the display. The functions keys retain their function, that means that the "Up"-key shows downwards in twisted mounting position!

## 11. Locking the set values

### 11.1 Standard versions

Whilst pushing the "Mode"-key, push the "Down"-key. The switch is locked, which means that the set values can't be changed. On the display appears "LoC", the switch is locked.

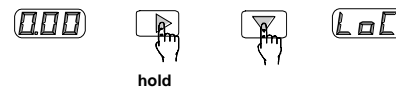

hold

When doing this once more, the switch gets unlocked and the settings can be changed again. On the display appears "UnC", the switch is unlocked.

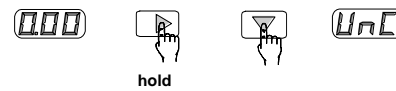

hold

### 11.2 Version with PIN code (VS-...-C)

The lock prevents unauthorised persons changing the settings. A 3-digit number combination (PIN code) guarantees that only people who know the PIN code (set by the operator) can change the settings.

Activating the lock:

To activate the lock, press and hold the "Mode" button, then press the "Down" button.

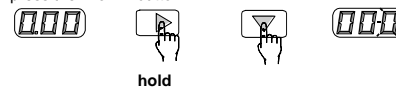

hold

Press the "Up" or "Down" button to change the right digit.



The value for the right digit is saved when you press the "Mode" button. The centre digit flashes.



1x

The centre digit can now be changed. Press the "Mode" button again to change the left digit.

When the "Mode" button is pressed again, the PIN code entered is saved. "LoC" appears on the display and the lock is activated.



1x

Deactivating the lock:

To deactivate the lock, press and hold the "Mode" button, then press the "Down" button.

"000" appears on the display and the right digit flashes.

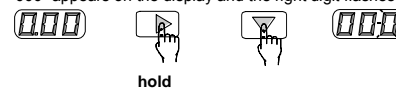

hold

The saved PIN code must be entered as described above for locking. If the PIN code is correct, "UnC" is displayed and the switch is unlocked.



1x

If the PIN code is incorrect, "LoC" is displayed and the switch remains locked.



1x

If you forget the PIN code saved, the switch can be unlocked in the SCHMALZ factory.

## 12. Error messages

Error	Message	Solution
	Pressure during Zero-point adjustment was higher than ±3% F.S.	Make Zero-point adjustment again at environment pressure.
	Overcurrent at Output 1	Loaded current exceeds rated power of 180mA max. Check output.
	Overcurrent at Output 2	
	Applied pressure exceeds measuring range.	Apply pressure within the measuring range.
	EEPROM defective, calibration storage could not be read anymore	Switch defective, replace it

\*A display change from 0.00 to -FF or e.g. 0.01 at a atmospheric pressure is not an error, but caused by fluctuations in the air pressure.

This can be rectified by setting the zero point.

The zero point must also be set after performing a "Clear all" (CLA).

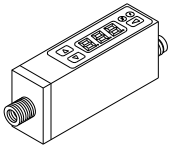

Vacuum Switch • Pressure Switch  
 Vakuum-Schalter • Druckschalter  
 Vacuostat • Pressostat  
 Conmutadores de vacío • Conmutadores de presión

**VS-D  
 Series**

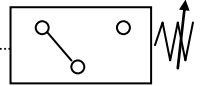

	VS-V-D-PNP	VS-V-D-PNP-C	VS-V-D-NPN	VS-P10-D-PNP	VS-P10-D-NPN
Art. # / Artikel-Nr. / No. de réf / Ref. Nº	10.06.02.00049	10.06.02.00270	10.06.02.00055	10.06.02.00056	10.06.02.00125
Pressure range / Druckbereich / Plage de pression / Margen de presión	0 ~ -1 bar (0 ~ -29.5 inHg)	0 ~ -1 bar (0 ~ -29.5 inHg)	0 ~ -1 bar (0 ~ -29.5 inHg)	0 ~ 10 bar (0 ~ 145 psi)	0 ~ 10 bar (0 ~ 145 psi)
Overpressure / Überdruck / Suppression / Sobrepresión	5 bar (72.5 psi)	5 bar (72.5 psi)	5 bar (72.5 psi)	16 bar (232 psi)	16 bar (232 psi)

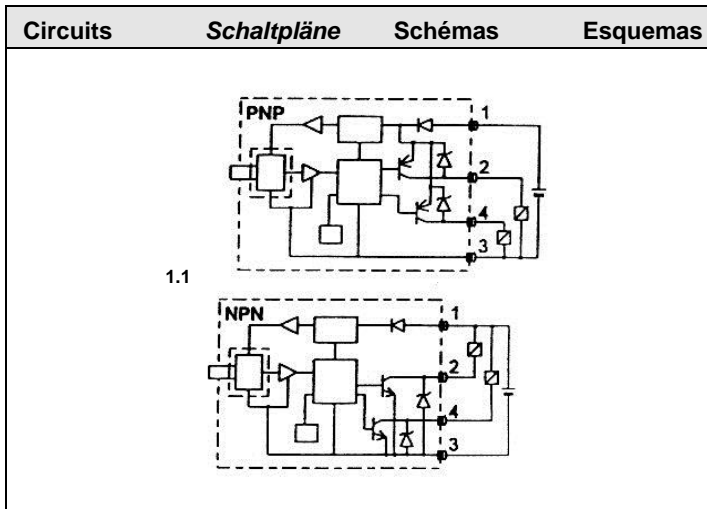

Pin Connection	Pinbelegung
1 V+	1 V+
2 Switch Output 2	2 Schaltausgang 2
3 V-	3 V-
4 Switch Output 1	4 Schaltausgang 1

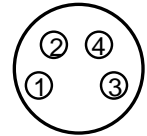

Connection	Conexiones
1 V+	1 V+
2 Sortie contact 2	2 Salida de contactos 2
3 V-	3 V-
4 Sortie contact 1	4 Salida de contactos 1

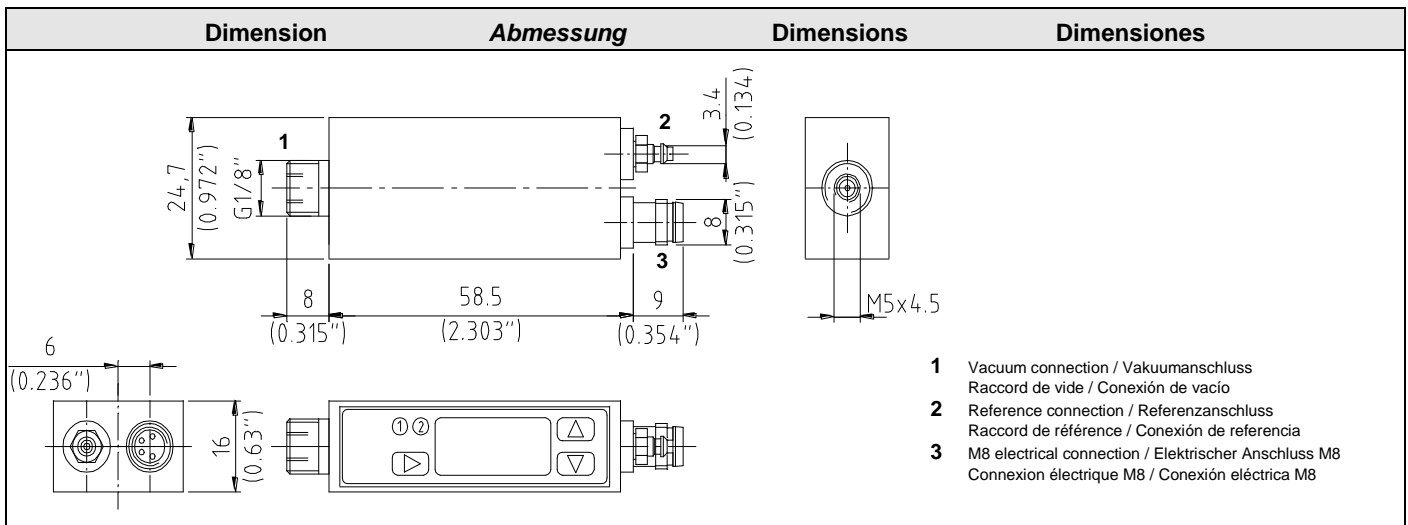

Colour codes of Schmalz cables / Farbkennung von Schmalz-Kabeln /  
 Marquage en couleur des câbles de Schmalz / Identificación de colores de los cables Schmalz

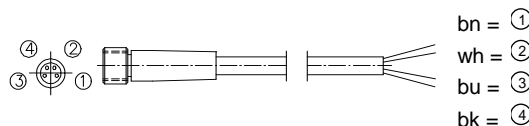

<p>If the switch is used in a moist environment, the reference connection (for ambient or reference pressure) must be connected to a deaeration hose (Ø 3 mm) which leads to a dry environment.</p>	<p>Wird der Schalter in feuchter Umgebung eingesetzt, muss der Referenzanschluss (für Umgebungs- oder Referenzdruck) mit einem Entlüftungsschlauch (Ø 3 mm) verbunden sein, der in trockener Umgebung endet.</p>	<p>Dans le cas d'une utilisation du commutateur en milieu humide, le raccordement de référence (pour pression de référence ou d'environnement) doit être branché à l'aide d'un tuyau de purge (Ø int. 3 mm) se terminant dans un environnement sec.</p>	<p>Si el interruptor se utiliza en entornos húmedos, la conexión de referencia (para la presión ambiental o la presión de referencia) debe estar conectada a una manguera de purga (Ø 3 mm) que desemboca en un entorno seco.</p>
---	--	---	---

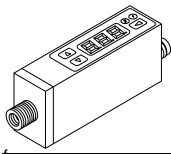

Vacuum Switch • Pressure Switch  
 Vakuumschalter • Druckschalter  
 Vacuostat • Pressostat  
 Conmutadores de vacío • Conmutadores de presión

**VS-D  
 Series**

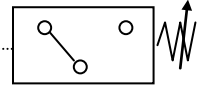

Technical Data		Technische Daten	
Media	Non corrosive gases and non lubricated air	Meßmedium	Nicht aggressive Gase und trockene ölfreie Luft
Power supply	10.8 ~ 30 VDC (Protected extra-low voltage PELV), Max. 10% ripple (P-P), Reverse voltage protection	Betriebsspannung	10,8 ~ 30 VDC (Schutzkleinspannung PELV), Max. 10% Welligkeit (P-P), Anschlüsse verpolungssicher
2 Switch Output	N.O. or N.C. separate selective, max. 180 mA, LED-indication on display, short circuit-proof, PNP or NPN version	2 Schaltausgänge	Wahlweise einstellbar N.O. oder N.C., max. 180 mA, LED-Anzeige, Kurzschlussfest, p-schaltend (PNP) oder n-schaltend (NPN)
Output resistance NPN	780 KΩ in open state	Ausgangswiderstand NPN	780 KΩ im offenen Zustand
Display	3-digit 7-segment LED	Anzeige	3-digit 7-segment LED
Pressure units	VS-V-D: bar, mmHg, inHg, kPa VS-P10-D: bar, psi, kgf/cm <sup>2</sup> , Mpa	Anzeigeoptionen	VS-V-D: bar, mmHg, inHg, kPa VS-P10-D: bar, psi, kgf/cm <sup>2</sup> , Mpa
Display resolution	VS-V-D: 0.01 bar, 5 mmHg, 0.2 inHg, 1 kPa VS-P10-D: 0.1 bar, 1 psi, 0.05 kgf/cm <sup>2</sup> , 0.01 Mpa	Anzeige Auflösung	VS-V-D: 0,01 bar, 5 mmHg, 0,2 inHg, 1 kPa VS-P10-D: 0,1 bar, 1 psi, 0,05 kgf/cm <sup>2</sup> , 0,01 Mpa
Hysteresis	Hysteresis mode (0-100%) or Windows Comparator mode separate selective	Hystereseeinstellung	Hysteresemodus einstellbar von 0 bis 100% der eingestellten Schaltpunkte oder Komparator Modus
Electrical connection	Connector M8, 4-pin	Elektrischer Anschluss	Steckanschluss M8, 4-pin
Air connection	M5F and G1/8" M	Anschluss Meßmedium	M5 IG und G1/8" AG
Protection	IP 65 (without venting tube IP40)	Schutzklasse	IP 65 (ohne Entlüftungsschlauch IP40)
Operation accuracy	± 1% F.S.	Wiederholgenauigkeit	± 1 % vom Meßbereich
Thermal error	± 3% F.S. in range 0 ~ 50 °C (32 ~ 122 °F)	Temperatureinfluss	± 3 % vom Meßbereich im Bereich 0 bis 50 °C
Response time	< 5 ms	Ansprechzeit	< 5 ms
Current consumption	< 55 mA	Eigenstromaufnahme	< 55 mA
Dielectric strength	1,000 VDC 1 min	Prüfspannung	1.000 VDC 1 min
Insulation resistance	> 100 MΩ at 500 VDC	Isolationswiderstand	> 100 MΩ bei 500 VDC
Interference emission	As per DIN EN 50081-1	Störaussendung	Geprüft nach DIN EN 50081-1
Immunity to interference	As per DIN EN 50082-2	Störfestigkeit	Geprüft nach DIN EN 50082-2
Operating temperature range	0 ~ 50 °C (32 ~ 122 °F)	Arbeitstemperatur	0 bis 50 °C
Storage temperature range	-10 ~ 60 °C (14 ~ 140 °F)	Lagertemperatur	-10 bis 60 °C
Operating humidity range	10 ~ 90 % RH	Zul. Luftfeuchtigkeit	10 ~ 90 % RH
Vibration resistance	10-55 Hz 1.5 mm (0.06"), XYZ, 2hrs	Schwingungsfestigkeit	10 bis 55 Hz 1,5 mm, XYZ, 2 Std.
Shock resistance	10 G XYZ	Schockfestigkeit	10 G XYZ
Mass	25 g (0.88 oz)	Gewicht	25 g
Immunity to interference: The following minimum operating quality is guaranteed when there is interference from electromagnetic HF-Fields as per ENV 50140 and ENV 50141: The switch point can be modified by max. 10%.		Störfestigkeit: Bei Einstrahlung elektromagnetischer HF-Felder nach ENV 50140 und Hochfrequenz nach ENV 50141 gilt folgende minimale Betriebsqualität: Der Schaltpunkt kann sich um max. 10 % verschieben.	

Données techniques		Características técnicas	
Fluides	Gaz non corrosifs et air filtré non lubrifié	Medio de medida	Gases no agresivos y aire seco y sin aceite
Alimentation	10,8 ~ 30 VDC (Très basse tension de protection PELV), Max. 10% ondulation (P-P), Protection inversion de polarité	Tensión de alimentación	10,8 - 30 VDC (Baja tensión de protección PELV), Máxima 10% ondulación (P-P), Protección contra inversiones de polaridad
2 Sortie contact	N.O. / N.F. (sélectif.), max. 180 mA, visualisation par LED, Protection contre surintensité, version PNP ou NPN	Dos salidas de conmutación	Posibilidad de configuración a NC o NO, conmutación p (PNP) o conmutación n (NPN), capacidad de conmutación máxima 180 mA señalización LED
Résistance sortie NPN	780 KΩ dans l'état ouvert	Resistencia salida NPN	780 KΩ en abierto estado
Affichage	3-digit 7-segment LED	Indicación	3-digit 7-segment LED
Unité de pression	VS-V-D: bar, mmHg, inHg, kPa VS-P10-D: bar, psi, kgf/cm <sup>2</sup> , Mpa	Opciones de indicación	VS-V-D: bar, mmHg, inHg, kPa VS-P10-D: bar, psi, kgf/cm <sup>2</sup> , Mpa
Résolution affichage	VS-V-D: 0.01 bar, 5 mmHg, 0.2 inHg, 1 kPa VS-P10-D: 0.1 bar, 1 psi, 0.05 kgf/cm <sup>2</sup> , 0.01 Mpa	Precisión de indicación	VS-V-D: 0.01 bar, 5 mmHg, 0.2 inHg, 1 kPa VS-P10-D: 0.1 bar, 1 psi, 0.05 kgf/cm <sup>2</sup> , 0.01 Mpa
Hystérésis	Sélection mode Hystérésis (0-100%) ou mode Comparateur à fenêtre	Histérésis de conmutación	Ajustable entre 0% y 100% de los puntos de conmutación o del modo de comparador seleccionado
Connexion électrique	Connecteur M8, 4-broches	Alimentación eléctrica	Conector macho M8 (4 polos)
Raccordement	M5F et G1/8" M	Conexión de vacío	Rosca interna M5, rosca exterior 1/8"
Protection	IP 65 (sans flexible IP40)	Clase de protección	IP 65 (sin tubo de salida de aire, IP 40)
Précision	± 1% E.M.	Precisión de repetición	± 1% del margen de medida
Erreur thermique	± 3% E.M., entre 0 ~ 50°C	Influencia de la temperatura	± 3 % del margen de medida (0 - 50 °C)
Temps de réponse	< 5 ms	Tiempo de activación	< 5 ms
Courant consommé	< 55 mA	Consumo de corriente	< 55 mA
Résistance diélectrique	1.000 VDC 1 min	Tensión de prueba	1000V AC, 1 min
Résistance d'isolation	> 100 MΩ á 500 VDC	Resistencia de aislamiento	> 100 MΩ á 500 VDC
Emission	Selon DIN EN 50081-1	Emisión de interferencias controladas	Según DIN EN 50081-1
Immunité	Selon DIN EN 50082-2	Resistencia a las interferencias	Según DIN EN 50082-2
Température d'utilisation	0 ~ 50 °C	Temperatura de trabajo	0 a 50 °C
Température de stockage	-10 ~ 60 °C	Temperatura de almacenamiento	-10 a 60 °C
Humidité	10 ~ 90 % RH	Grado de humedad del aire	10 ~ 90 %, humedad relativa
Résistance aux vibrations	10 ~ 55 Hz 1,5 mm, XYZ, 2 hrs	Resistencia avibraciones	10 a 55 Hz, 1,5 mm, XYZ, 2 horas
Résistance aux chocs	10 G XYZ	Resistencia a impactos	10 G XYZ
Masse	25 g	Peso	25 g
Immunité : Qualité de fonctionnement minimum garantie en présence de champs électromagnétiques HF selon ENV 50140 et haute fréquence selon ENV 50141:Le point de commutation varie de max. 10%.		Resistencia a las interferencias : En caso de irradiación de campos magnéticos de alta frecuencia según ENV 50140 y ENV 50141, tiene validez la siguiente calidad de funcionamiento mínima: La punto de conmutación máximo varía en 10%.	

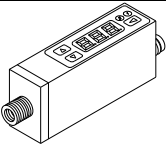

# Brief Operating Instructions Vacuum Switch

## VS-V-D-PNP

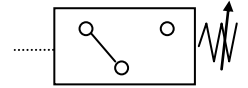

### Brief Operating Instructions Vacuum Switch

#### 1 Display

- "Mode" key                      Used to select the various setting procedures
- Function keys "Up"/"Down"    Used to change the settings
- LED Output 1                    Indicate the switching states: Output 1 = red,
- and Output 2                    Output 2 = green

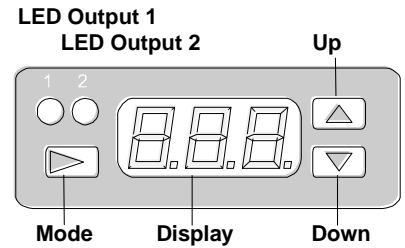

#### 2 Setting the Zero Point

The zero point is set with the air and pressure hoses disconnected by pressing and holding the "Mode" key for at least 3 seconds.

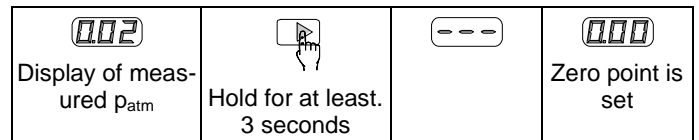

#### 3 Setting the Switching Point and Hysteresis

##### 3.1 Output 1

- ⇒ To set the switching point of Output 1, press the "Mode" key once.
- ⇒ After two seconds, the display starts to alternate between "H-1" and the current setting.
- ⇒ To change the setting, press the function key "Up" or "Down" until the desired value is displayed.
- ⇒ Store the new setting by pressing the "Mode" key
- ⇒ The display now changes to the hysteresis value, alternating between "h-1" and the current setting.
- ⇒ To change the setting, press the function key "Up" or "Down" until the desired value is displayed.
- ⇒ Store the new setting by pressing the "Mode" key

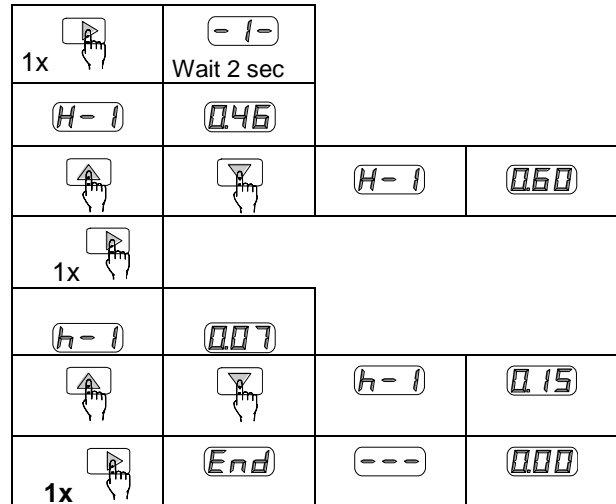

##### 3.2 Output 2

- ⇒ To set the switching point of Output 2, press the "Mode" key three times.
- ⇒ After two seconds, the display starts to alternate between "H-2" and the current setting.
- ⇒ To change the setting, press the function key "Up" or "Down" until the desired value is displayed.
- ⇒ Store the new setting by pressing the "Mode" key
- ⇒ The display now changes to the hysteresis value, alternating between "h-2" and the current setting.
- ⇒ To change the setting, press the function key "Up" or "Down" until the desired value is displayed.
- ⇒ Store the new setting by pressing the "Mode" key

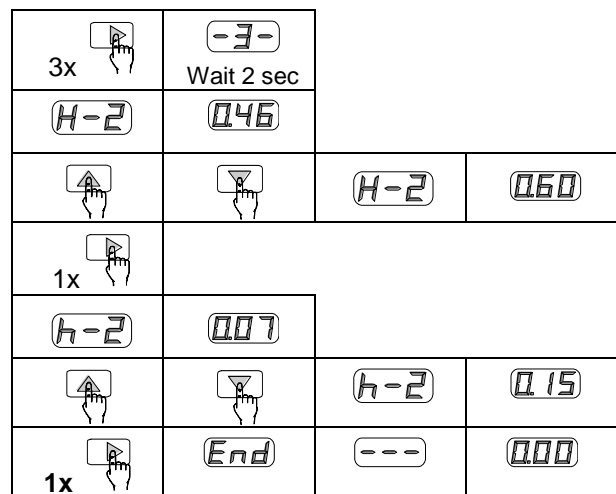

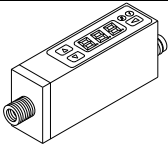

# Brief Operating Instructions Vacuum Switch

## VS-V-D-PNP

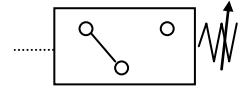

### 4 Operating Mode "Hysteresis"

For each output, there is a **switching point H** and a **Hysteresis h**.

Example:  $H_1 = -0.46 \text{ bar}$ ,  $h = 0.07 \text{ bar}$ , NO (Normally Open)

At 0 bar, the digital output is off.

When the vacuum reaches the **switching point H**, the digital output switches to on and remains on as long as the vacuum is greater than  $-0.39 \text{ bar}$  ( $= 0.46 \text{ bar} - 0.07 \text{ bar}$ ). If the vacuum drops below  $-0.39 \text{ bar}$ , the digital output switches to off.

If the setting NC (Normally Closed) is selected, the signals at the digital output are inverted (off at vacuum  $> H$ , on at vacuum  $< H-h$ ).

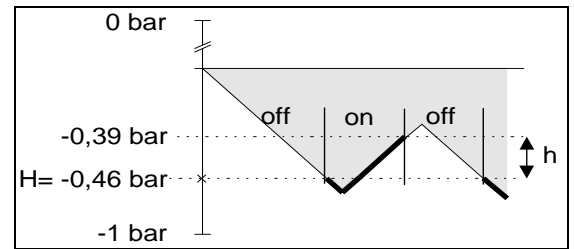

### 5 Locking the Settings

The locking function prevents inadvertent changing of the selected settings.

To lock the settings, press and hold the "Mode" key and press the "Down" key. The display then shows **LoC** to indicate that the settings are locked.

To deactivate the lock, press and hold the "Mode" key and press the "Down" key. The display then shows **UnC** to indicate that the settings are unlocked.

	Hold		
	Hold		

### Notes

This document is an abbreviated summary of the standard documentation. Please consult the standard documentation if you need to change any settings not described here.

### Default settings

Switching point 1	Hysteresis	Switching point 2	Hysteresis
H - 1	h - 1	H - 2	h - 2
0.46 bar	0.07 bar	0.79 bar	0.07 bar



## Operation instructions evacuation time counter

### Programming

#### Access to programming mode

- A. Press both buttons at the front and switch on the power supply, or press both buttons for five seconds if power supply is already switched on.
- B. The display shows

*Pr o G*

- C. If the buttons are released the display shows

*no*

By pressing the right button the display shows

*YES*

- D. Switch to the first parameter by pressing left button and actuate right button.
- E. As soon as the button is released, the title of the menu as well as the current adjustment of the menu is displayed in exchange.
- F. By pressing the right button the the next adjustment of the menu is shown. If numerical values have to be entered, the decade is chosen with the left button and the value is adjusted with the right button.
- G. Switching to the next menu item by pressing left button and activating right button.
- H. The last menu item "EndPro" enables leaving of the menu and storing of new values by choosing "Yes". If "No" is chosen, the programming process starts again and the at last adjusted values are preserved. These can be altered and controlled again.

## Necessary Adjustments

Menu item	Adjustment
InPol	PnP
FILTEr	off
StArt	InR. Inb
P7ode	5EE
dPtIn	0.000
rESnrd	P7RnrE
EndPro	YES