



## Operating Instructions

# Vacuum pump EVE-OG 10-16

**Note**

The Operating instructions were originally written in German. Store in a safe place for future reference. Subject to technical changes without notice. No responsibility is taken for printing or other types of errors.

**Published by**

© J. Schmalz GmbH, 08/22

This document is protected by copyright. J. Schmalz GmbH retains the rights established thereby. Reproduction of the contents, in full or in part, is only permitted within the limits of the legal provisions of copyright law. Any modifications to or abridgments of the document are prohibited without explicit written agreement from J. Schmalz GmbH.

**Contact**

J. Schmalz GmbH  
Johannes-Schmalz-Str. 1  
72293 Glatten, Germany  
T: +49 7443 2403-0  
schmalz@schmalz.de  
www.schmalz.com

Contact information for Schmalz companies and trade partners worldwide can be found at:  
[www.schmalz.com/salesnetwork](http://www.schmalz.com/salesnetwork)

# Contents

<b>1</b>	<b>Important Information</b>	<b>5</b>
1.1	Note on Using this Document	5
1.2	The technical documentation is part of the product	5
1.3	Symbol	5
<b>2</b>	<b>Fundamental Safety Instructions</b>	<b>6</b>
2.1	Intended Use	6
2.2	Personnel qualification	6
2.3	Warnings in This Document	6
2.4	Residual Risks	6
2.5	Changes to the Vacuum Generator	7
<b>3</b>	<b>Product Description</b>	<b>8</b>
3.1	Vacuum Pump Components	8
3.2	Functional Principle	8
3.3	Application Area	9
3.4	On/Off Switch	9
<b>4</b>	<b>Technical Data</b>	<b>10</b>
4.1	General Parameters	10
4.2	Oil	10
<b>5</b>	<b>Transport and Storage</b>	<b>11</b>
5.1	Checking the Delivery	11
5.2	Transporting the Vacuum Pump	11
5.3	Storage	12
<b>6</b>	<b>Installation</b>	<b>13</b>
6.1	Installation Instructions	13
6.2	Mounting	14
6.3	Checking the oil level	14
6.4	Filling with Oil	15
6.5	Pneumatically Connecting the Vacuum Pump	15
6.6	Electrical Connection	16
<b>7</b>	<b>Operation</b>	<b>19</b>
7.1	Safety Instructions	19
7.2	Version with Oil Return Valve	19
7.3	Conveying Condensable Vapors	20
<b>8</b>	<b>Maintenance</b>	<b>21</b>
8.1	Safety Instructions	21
8.2	Maintenance Plan	22
8.3	Changing the Oil	22
8.4	Changing the Air-Oil Separator	24
8.5	Cleaning the Pump	25
<b>9</b>	<b>Warranty</b>	<b>26</b>

<b>10 Repair</b> .....	<b>27</b>
<b>11 Troubleshooting</b> .....	<b>28</b>
11.1 Safety Instructions for Troubleshooting .....	28
11.2 Troubleshooting .....	28
<b>12 Optional Accessories</b> .....	<b>31</b>
12.1 Gas ballast valve .....	31
12.2 Inlet Filter.....	31
<b>13 Spare and Wearing Parts</b> .....	<b>32</b>
<b>14 Taking the Product Out of Operation and Disposal</b> .....	<b>33</b>
<b>15 EU Conformity</b> .....	<b>34</b>
<b>16 UKCA Conformity</b> .....	<b>35</b>
<b>17 Declaration of Decontamination</b> .....	<b>36</b>

# 1 Important Information

## 1.1 Note on Using this Document

J. Schmalz GmbH is generally referred to as Schmalz in this document.

The document contains important notes and information about the different operating phases of the product:

- Transport, storage, start of operations and decommissioning
- Safe operation, required maintenance, rectification of any faults

The document describes the product at the time of delivery by Schmalz and is aimed at:

- Installers who are trained in handling the product and can operate and install it
- Technically trained service personnel performing the maintenance work
- Technically trained persons who work on electrical equipment

## 1.2 The technical documentation is part of the product

1. For problem-free and safe operation, follow the instructions in the documents.
2. Keep the technical documentation in close proximity to the product. The documentation must be accessible to personnel at all times.
3. Pass on the technical documentation to subsequent users.
  - ⇒ Failure to follow the instructions in these Operating instructions may result in life-threatening injuries!
  - ⇒ Schmalz is not liable for damage or malfunctions that result from failure to heed these instructions.

If you still have questions after reading the technical documentation, contact Schmalz Service at:  
[www.schmalz.com/services](http://www.schmalz.com/services)

## 1.3 Symbol



This symbol indicates useful and important information.

- ✓ This symbol represents a prerequisite that must be met prior to an operational step.
- ▶ This symbol represents an action to be performed.
- ⇒ This symbol represents the result of an action.

Actions that consist of more than one step are numbered:

1. First action to be performed.
2. Second action to be performed.

## 2 Fundamental Safety Instructions

### 2.1 Intended Use

The vacuum pump is built in accordance with the latest standards of technology and is delivered in a safe operating condition.

The vacuum pump from Schmalz is designed for the suction of air and other dry, non-aggressive, non-toxic, and non-explosive gases.

Neutral gases in accordance with EN 983 are approved as evacuation media. Neutral gases include air, nitrogen and inert gases (e.g. argon, xenon and neon).

Conveying other media increases the thermal and/or mechanical load on the machine and must only be performed in consultation with J. Schmalz.

The vacuum pump is designed for indoor use; in the case of outdoor installation, contact Schmalz so that special precautions can be taken if necessary.

The product is intended for industrial use.

Intended use includes observing the technical data and the installation and operating instructions in this manual.

### 2.2 Personnel qualification





Unqualified personnel cannot recognize dangers and are therefore exposed to higher risks!

1. Electrical work and installations may only be carried out by qualified electrical specialists.
2. Assembly and adjustment work may only be carried out by qualified personnel.

These operating instructions are intended for fitters who are trained in handling the product and who can operate and install it.

### 2.3 Warnings in This Document

Warnings warn against hazards that may occur when handling the product. The signal word indicates the level of danger.

Signal word	Meaning
 <b>DANGER</b>	Indicates a high-risk hazard that will result in death or serious injury if not avoided.
 <b>WARNING</b>	Indicates a medium-risk hazard that could result in death or serious injury if not avoided.
 <b>CAUTION</b>	Indicates a low-risk hazard that could result in minor or moderate injury if not avoided.
 <b>NOTE</b>	Indicates a danger that leads to property damage.

### 2.4 Residual Risks



#### **WARNING**

##### **Risk of fire and explosion caused by sparks**

Serious injury!

- ▶ Do not use the product in environments where there is a risk of explosion.

**CAUTION****Vacuum close to the eye**

Severe eye injury!

- ▶ Wear eye protection.
- ▶ Do not look into vacuum openings, e.g. suction cups.

**WARNING****Extraction of hazardous media, liquids or bulk material**

Personal injury or damage to property!

- ▶ Do not extract harmful media such as dust, oil mists, vapors, aerosols etc.
- ▶ Do not extract aggressive gases or media such as acids, acid fumes, bases, biocides, disinfectants or detergents.
- ▶ Do not extract liquids or bulk materials, e.g. granulates.

## 2.5 Changes to the Vacuum Generator

Schmalz assumes no liability for consequences of modifications over which it has no control:

1. The vacuum generator must be operated only in its original condition as delivered.
2. Use only original spare parts from Schmalz.
3. The vacuum generator may be operated only in perfect condition.

## 3 Product Description

### 3.1 Vacuum Pump Components

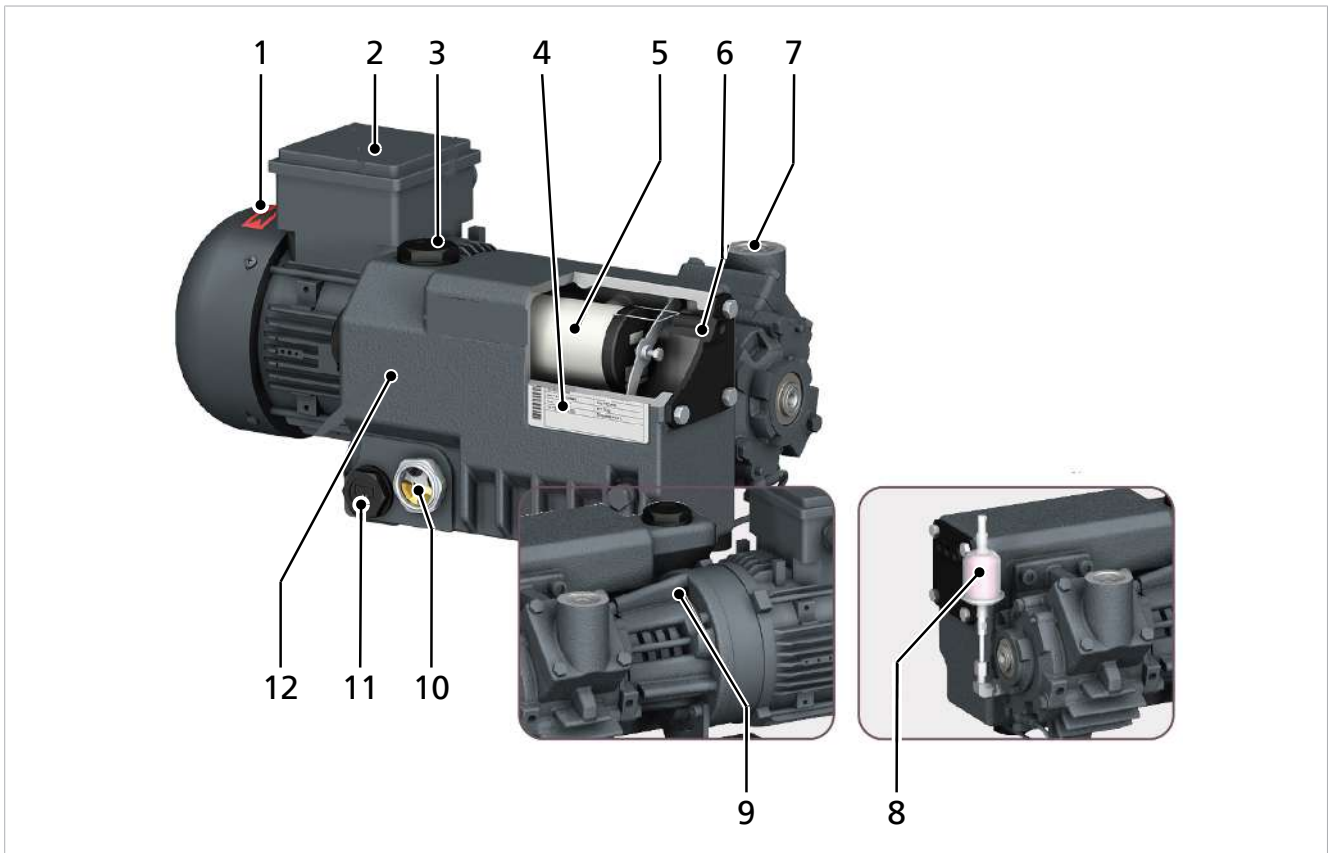

1	Directional arrow	7	Vacuum connection
2	Motor terminal box	8	Gas ballast valve
3	Oil filler plug	9	Transport lugs
4	Type plate, vacuum pump	10	Oil sight glass
5	Air-oil separator	11	Oil drain screw
6	Outlet connection	12	Oil separator

### 3.2 Functional Principle

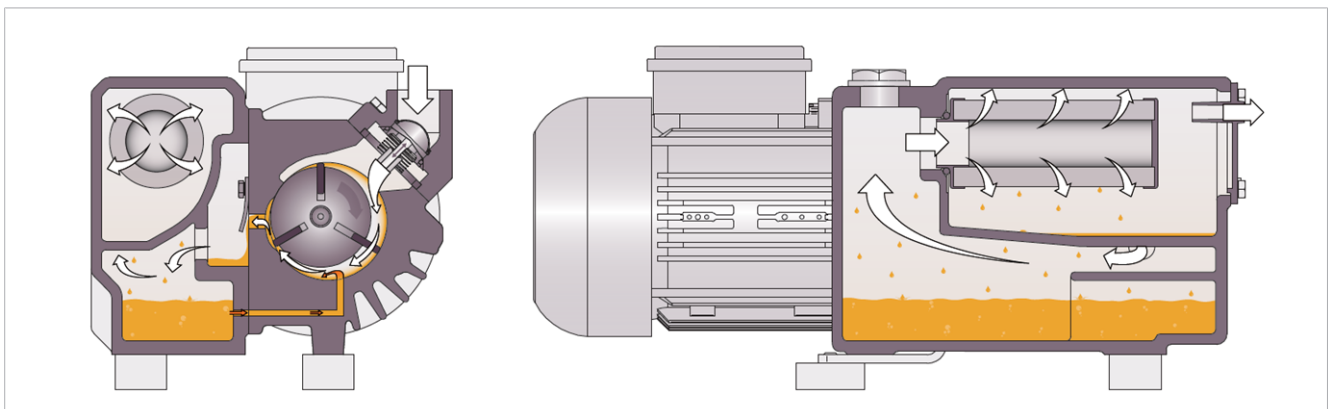



The vacuum pump functions according to the rotary vane principle.

The oil seals the gaps, lubricates the slides, and dissipates compression heat.

The oil seals the gaps, lubricates the slides, and dissipates compression heat.

Exhaust gas filters then separate the oil from the discharged gas.

### **3.3 Application Area**

Version with float valve (standard):

The machine is suitable for continuous operation.

Version with oil return valve:

During operation, oil collects at the bottom of the upper chamber of the oil separator and cannot flow into the lower chamber during machine operation.

After no more than 10 hours of continuous operation, or if the pressure difference between the vacuum and pressure side is high after a shorter period of time, the machine must be switched off for at least 15 minutes to allow the oil to flow from the upper chamber of the oil separator into the lower chamber.

### **3.4 On/Off Switch**

The vacuum pump is supplied without an on/off switch. The vacuum pump must be controlled at the site of installation.

The vacuum pump can optionally be equipped with a starter unit or a frequency-controlled drive.

## 4 Technical Data

### 4.1 General Parameters

Oil-lubricated rotary vane vacuum pump:

Parameter	Unit	EVE-OG 10	EVE-OG 16
Nominal suction rate (50 Hz / 60 Hz)	m <sup>3</sup> /h	10/12	16/19
Max. vacuum (without gas ballast valve)	mbar	980	
Motor rated speed (50 Hz / 60 Hz)	rpm	1500 / 1800	
Motor rated power (50 Hz / 60 Hz)	kW	0.5 / 0.7	
Power consumption at 100 mbar (50 Hz / 60 Hz)	kW	0.36 / 0.41	0.49 / 0.59
Power consumption at final pressure (50 Hz / 60 Hz)	kW	0.33 / 0.37	0.39 / 0.48
Sound pressure level (EN ISO 2151) (50 Hz / 60 Hz)	dB(A)	53 / 56	54 / 56
Operating temperature (50Hz/60Hz)	° C	74 / 76	76 / 81
Ambient temperature range	° C	See oil	
Ambient pressure	—	Atmospheric pressure	
Oil quantity	l	0.4	
Approximate weight	kg	19	

For exact electrical and pneumatic data, refer to the type plate and/or data sheet.

### 4.2 Oil

Description	Value
Designation	OEL-EVE- ....ANDEROL 555
ISO-VG	100
Basis	Synthetic diester
Ambient temperature range [°C]	5 to 40
Part no. for 1 L packaging	27.02.01.00055
Part no. for 5 L packaging	27.02.01.00056

The type plate displays the type of oil used to fill the vacuum pump.

## 5 Transport and Storage

### 5.1 Checking the Delivery

The scope of delivery can be found in the order confirmation. The weights and dimensions are listed in the delivery notes.

1. Compare the entire delivery with the supplied delivery notes to make sure nothing is missing.
2. Damage caused by defective packaging or occurring in transit must be reported immediately to the carrier and J. Schmalz GmbH.

### 5.2 Transporting the Vacuum Pump

- ✓ Wear protective work shoes and gloves.

  1. Secure the load according to national regulations before every transport operation.
  2. Ensure that the hoists and slings used have the necessary specifications.
  3. Ensure that any personnel involved in transporting with lifting devices or industrial trucks are authorized and qualified to do so.



#### **⚠ WARNING**

##### **Suspended load.**

Risk of injury!

- ▶ Do not walk, stand or work under suspended loads.



#### **⚠ CAUTION**

##### **Moving or carrying the product by hand.**

Risk of injury!

- ▶ Do not lift products that weigh more than 20 kg by hand.
- ▶ Observe all safety regulations to protect against accidents.
- ⇒ E.g. wear PPE (gloves, safety shoes, helmet)



#### **NOTE**

##### **Tilting a vacuum pump filled with oil**

Tilting a vacuum pump filled with oil can cause large quantities of oil to enter the cylinder. The slides will be damaged if the vacuum pump is started while there is an excessive amount of oil in the cylinder. This will destroy the vacuum pump.

- ▶ Before transporting, always drain the oil or transport the vacuum pump in a horizontal position.

- ✓ The eye bolt must be in perfect condition, completely screwed in, and hand-tightened.
- ▶ Check the vacuum pump for transport damage.

If the vacuum pump is mounted to a base plate, proceed as follows:

- ▶ Remove the mounting.



## **WARNING**

### **Lifting the vacuum pump from the eye bolt of the motor**

Risk of serious injury!

- ▶ Do not lift the vacuum pump by the eye bolt of the motor, but rather as illustrated above.

---

Before commissioning, check and top up the oil in the pump according to the indication on the oil level indicator.



Commissioning the vacuum pump without sufficient oil will destroy it.

## **5.3 Storage**

- ▶ Seal all openings with adhesive tape or reuse the caps included in delivery.

Proceed as follows if storing for longer than 3 months:

1. Wrap the vacuum pump with anti-corrosive plastic film.
2. Store the vacuum pump in a protected, dry and dust-free room, preferably in its original packaging and at a temperature between 0 and 40° C.

## 6 Installation

### 6.1 Installation Instructions



#### CAUTION

##### Improper installation or maintenance

Personal injury or damage to property

- ▶ Prior to installation and before maintenance work, the vacuum generator must be disconnected from the power supply and secured against unauthorized restart!



#### NOTE

##### Using the Vacuum pump outside the permissible installation conditions.

Danger of premature failure of the machine and loss of efficiency.

- ▶ The installation conditions must comply with all specifications.

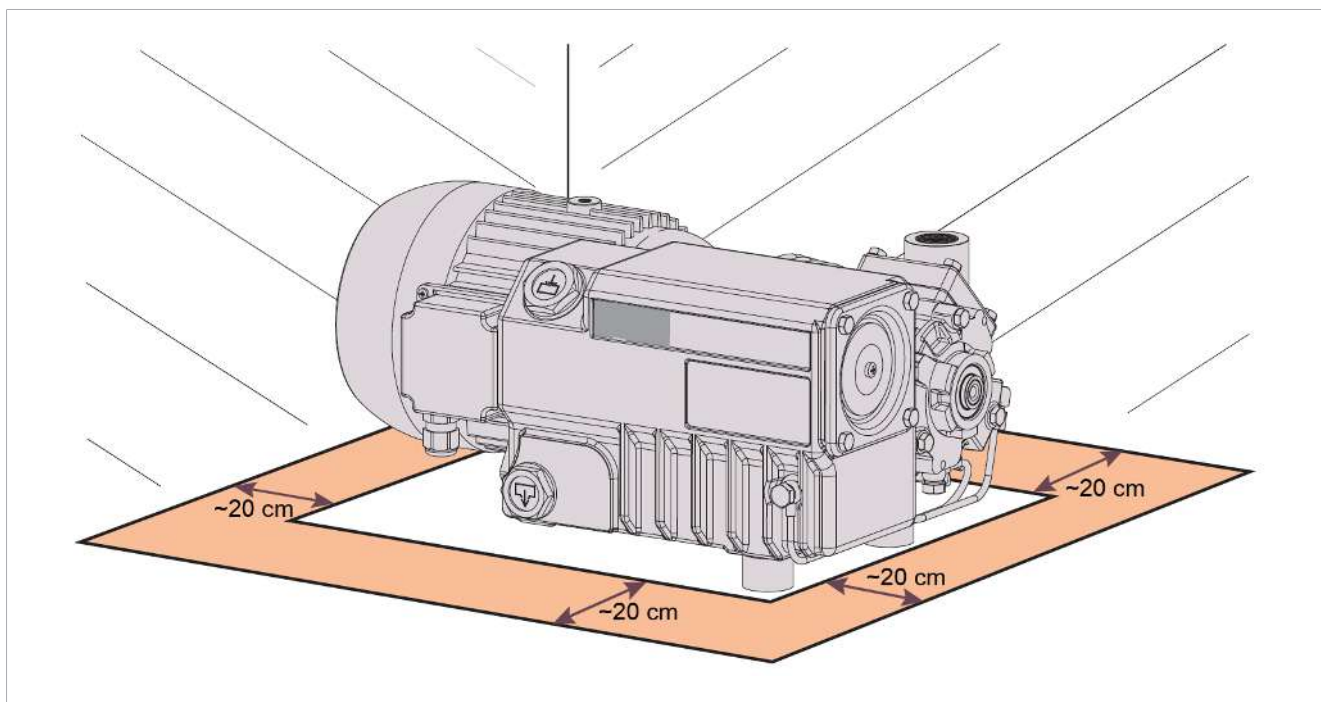

For safe installation, the following instructions must be observed:

- ✓ The machine must not be in a potentially explosive environment.
- ✓ The ambient conditions must comply with the specifications contained in the technical data.
- ✓ The installation site must be ventilated to ensure sufficient cooling of the machine.
- ✓ The oil sight glass must be visible at all times.
- ✓ Sufficient space for maintenance work must be provided.

1. Ensure that the environmental conditions comply with the motor protection class and electrical devices.
2. Ensure that the ventilation openings (inlets and outlets) are not covered and that the cooling air can flow freely.
3. Check the oil level.
4. Ensure that all covers, guards, etc. are attached.
5. Use only the connectors, mounting holes and attachment materials that have been provided.
6. Firmly connect and secure pneumatic and electrical line connections to the vacuum generator.

If the vacuum pump is installed higher than 1,000 meters above sea level:

- ▶ Contact a Schmalz representative. The motor power must be limited or the ambient temperature must be restricted.

## 6.2 Mounting

Before mounting the pump at the installation location, bring it to the ambient temperature.

1. Ensure that the machine is set up and attached horizontally. A deviation of 1° in any direction can be tolerated.
2. Remove all protective caps before installation.

Tension or pressure must not be applied to the connections via the connection lines. If necessary, use flexible connections.

The line cross-section of the connection lines must have at least the same cross-section as the machine connections over the entire length.

If the connection lines are very long, it is advisable to use larger line cross-sections to avoid loss of efficiency. Contact a Schmalz representative.

## 6.3 Checking the oil level

1. Switch off the vacuum pump.
2. After switching off the vacuum pump, wait 1 minute before checking the oil level.

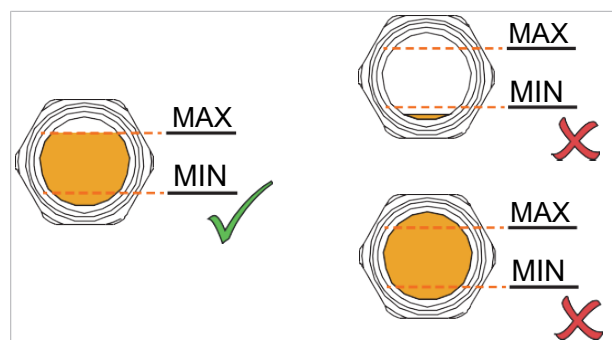

3. If necessary, top up with oil as described in (> [See ch. 6.4 Filling with Oil, Page 15](#)).

## 6.4 Filling with Oil



### NOTE

#### Use of unsuitable oil or too little oil.

Danger of premature failure and damage to the vacuum pump.

- ▶ Only use oils approved and recommended by Schmalz.
- ▶ Maintain the oil level between the MIN and MAX marks.

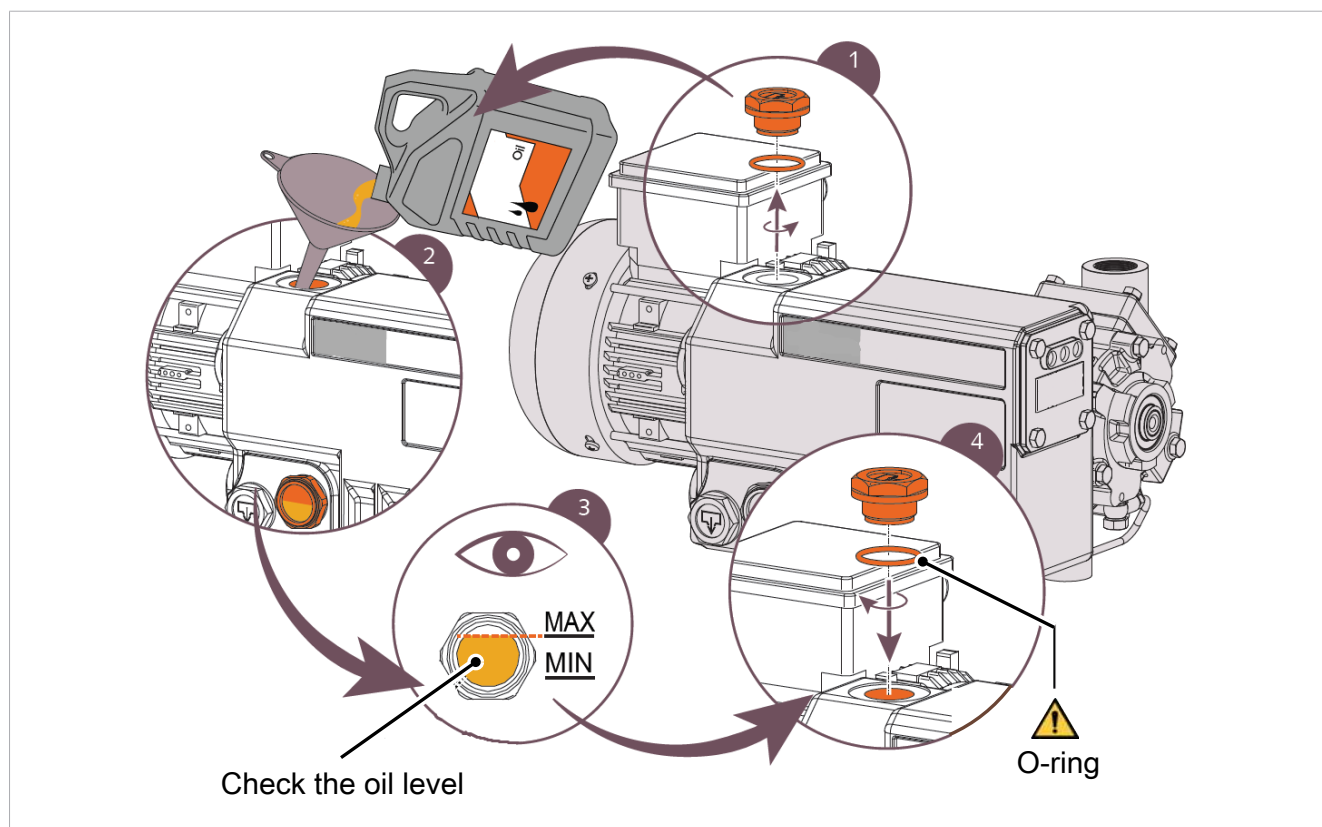

## 6.5 Pneumatically Connecting the Vacuum Pump



### ⚠ CAUTION

#### The discharged gas contains minimal amounts of oil.

Health risk

- ▶ If the air is directed into rooms where people are present, ensure adequate ventilation.



### NOTE

#### Ingress of foreign bodies or liquids.

Danger of damage to the machine.

- ▶ If the gas that is sucked in contains dust or other solids, install a suitable filter ( $\leq 5$  microns) in front of the inlet of the machine.

Use only hoses that are designed for the maximum permitted pump operating pressure (see the chapter "Technical Data"). Use only hoses that have sufficient chemical resistance to the gases to be conveyed.

**Connecting the vacuum connection:****⚠ WARNING****A powerful vacuum flow creates a strong suction effect**

Risk of injury to eyes or other body parts

- ▶ Wear eye protection.
- ▶ Do not look or reach into the vacuum opening.
- ▶ When the vacuum generator is switched on, maintain a safe distance from the vacuum opening.

1. Remove the protective plug.
2. Connect the suction line to the vacuum connection. The connection size is: G3/4
3. Check that the hoses and junctions are connected correctly and tightly.
4. Check that the installation is sealed tight.

**Exhaust air connection:**

Connection size:

— Without connection. The discharged gas is discharged into the ambient air of the vacuum pump.

The connection dimensions may vary for specific orders.

- ▶ Ensure that the discharged gas can flow out freely. Never close the exhaust air line, throttle it or use it as a source of compressed air.

If the air that was sucked in is not discharged into the environment around the immediate vicinity of the vacuum pump, observe the following:

- ▶ Lay the exhaust air line sloping down to the vacuum pump or install a liquid condenser or a condensation collector pipe with a drain valve to prevent liquid from running back into the machine.

**6.6 Electrical Connection****⚠ DANGER****Electrocution by live components or wires**

Serious injury or death!

- ▶ Electrical installation work may only be carried out by qualified personnel.
- ▶ Make sure that the electrical components are not live before installation, maintenance and troubleshooting.
- ▶ Switch off the mains switch and secure against unauthorized restart.



The electrical installation must comply with applicable national and international standards, guidelines and regulations.

- ✓ The power supply for the motor must comply with the specifications on the motor type plate.
- 1. Install a lockable disconnecting switch on the power supply so that the vacuum pump can be completely disconnected during maintenance operations.
- 2. Install overload protection for the motor according to EN 60204-1. (Schmalz recommends installing a D-curve circuit breaker).
- 3. Ensure that the vacuum pump motor is not affected by electrical or electromagnetic pulses from the power supply.
- 4. Connect the protective conductor.
- 5. Connect the motor to the power supply.



## NOTE

### Incorrect electrical connection of the vacuum pump

Danger of motor damage.

- ▶ The following circuit diagrams show the typical wirings. Check that the motor terminal box contains instructions for the cabling/circuit diagrams.

### 6.6.1 Circuit diagrams for three-phase motor

Delta connection (low voltage):

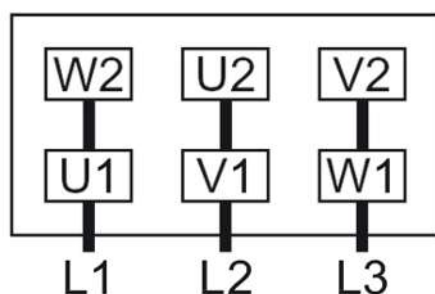

Star connection (high voltage):

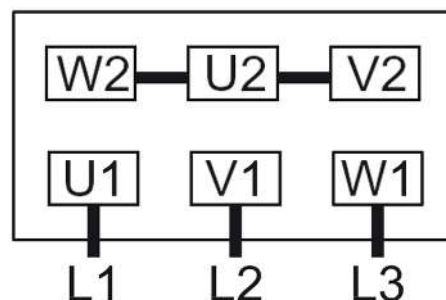

Double star connection, multi-voltage motor with 9 pins (low voltage):

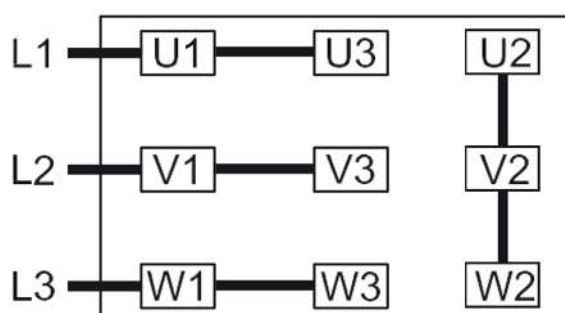

Star connection, multi-voltage motor with 9 pins (high voltage):

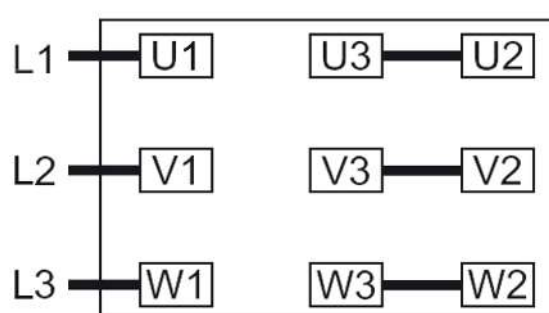

### 6.6.2 Checking the Direction of Rotation



#### NOTE

#### Electric motor running in the wrong direction

Damage to the motor

- ▶ Reverse the rotational direction by reversing the polarity in the supply line.

For three-phase A.C. motors, check the direction of rotation of the motor as follows:

1. Switch on the vacuum pump for a fraction of a second.

2. Watch the motor's fan blade. It must rotate in the direction shown by the arrow on the motor housing.



3. The device is delivered with a clockwise rotation field. If the direction of rotation is incorrect, switch the unit off immediately and reverse the connection in the supply line.
4. Check the direction of rotation once again.



Damage or destruction of the motor resulting from operation with the incorrect rotational direction is not covered by the warranty.

## 7 Operation

### 7.1 Safety Instructions



#### ⚠ CAUTION

##### Touching hot surfaces

Touching hot surfaces may cause injury from burns.

- ▶ Wear work gloves.
- ▶ Do not touch components during operation.
- ▶ Allow the components to cool down before commencing work on the product.



#### ⚠ CAUTION

##### Noise pollution caused by machine during operation

Danger of hearing damage

- ▶ If you spend longer periods of time in the immediate vicinity of the machine when it is not soundproofed: Wear ear protectors.



#### NOTE

##### Use of unsuitable oil or too little oil.

Danger of premature failure and damage to the vacuum pump.

- ▶ Only use oils approved and recommended by Schmalz.
- ▶ Maintain the oil level between the MIN and MAX marks.

- ▶ Switch on the machine.

The permitted maximum number of starts of 12 times per hour must not be exceeded. The individual starts must be distributed over the period of one hour.

- ▶ Check the oil level after a few minutes of machine operation and top up oil if necessary.

Once the machine is operating under normal conditions, proceed as follows:

- ▶ Measure the strength of the motor current and record it for reference purposes for future maintenance and troubleshooting.

### 7.2 Version with Oil Return Valve

During operation, oil collects at the bottom of the upper chamber of the oil separator and cannot flow into the lower chamber during machine operation.

After 10 hours of continuous operation of the vacuum pump, and if there is a high pressure difference between the vacuum and the overpressure side, proceed as follows:

- ▶ Switch off the machine for at least 15 minutes.
- ⇒ This allows the oil to flow from the upper chamber of the oil separator to the lower chamber.

### 7.3 Conveying Condensable Vapors

A certain amount of water vapor in the gas flow is tolerated. Contact Schmalz for information on how to convey other vapors.

When conveying condensable vapors, observe the following:

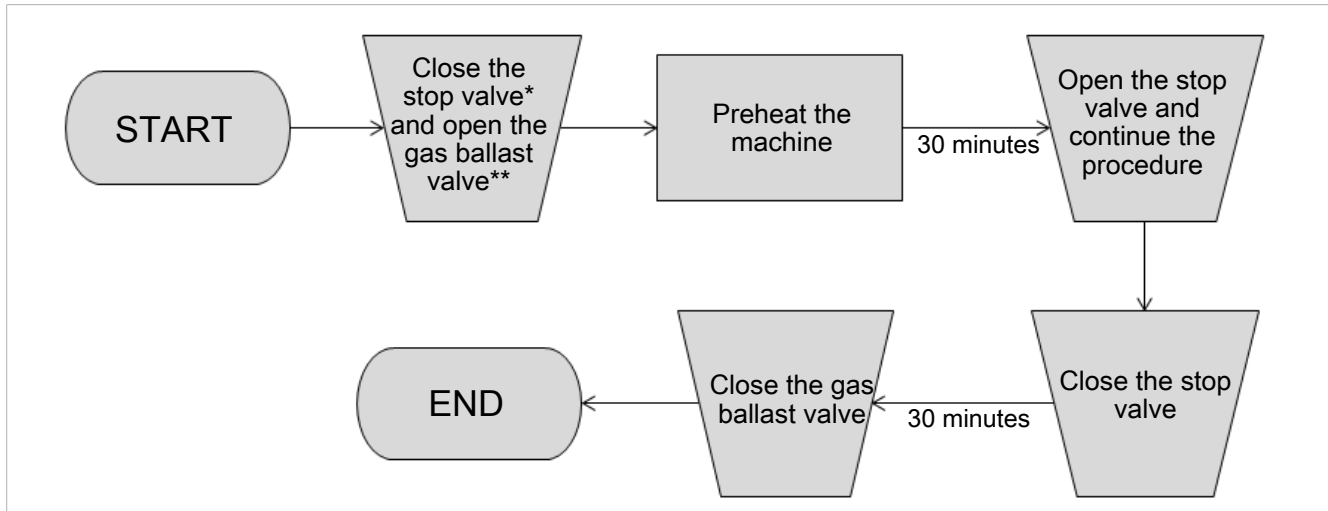

\*Not included in the scope of delivery.

\*\*May be an optional piece of equipment for some products

The gas ballast valve (optional) must be open.

## 8 Maintenance

### 8.1 Safety Instructions



#### **⚠ WARNING**

##### **Machine contaminated with hazardous material.**

Danger of poisoning. There is a risk of infection.

- ▶ Wear appropriate personal safety equipment.



#### **⚠ CAUTION**

##### **Touching hot surfaces**

Touching hot surfaces may cause injury from burns.

- ▶ Wear work gloves.
- ▶ Do not touch components during operation.
- ▶ Allow the components to cool down before commencing work on the product.



#### **⚠ CAUTION**

##### **Failure to properly maintain the machine.**

Risk of injury!

Risk of premature machine failure and loss of efficiency.

- ▶ Observe the maintenance intervals or contact your Schmalz representative. He or she will be glad to help you.

1. Switch off and lock the vacuum pump to prevent it from accidentally switching on.
2. Vent all connected lines to the atmospheric pressure.
3. If necessary, disconnect all connections.

## 8.2 Maintenance Plan

The maintenance intervals are very dependent on the individual operating conditions. The intervals provided below should be considered guidelines and individually shortened or extended.

It may be necessary to significantly shorten the maintenance intervals, particularly in the case of a heavy workload, high dust exposure in the environment or the process gas, or other contamination, or the ingress of process material.

Maintenance work	Interval	
	Normal use	Heavy workload
▶ Check the oil level.	Daily	
▶ Check the vacuum pump for leaking oil. If there is a leak, have the vacuum pump repaired by Schmalz. If a suction filter is installed, observe the following: ▶ Check the suction filter insert and replace it if necessary.	Monthly	
▶ Replace the oil, oil filter, and air-oil separators and exhaust gas filter.	After max. 4,000 hours or 1 year at the latest	After max. 2,000 hours or 6 months at the latest
▶ Clean dust and contamination from the vacuum pump. If a gas ballast valve is installed, observe the following: ▶ Clean the gas ballast valve filter. If the vacuum pump is equipped with an air-oil heat exchanger: ▶ Check and/or clean the air-oil heat exchanger.	Every 6 months	
▶ Perform a general overhaul of the vacuum pump (contact Schmalz).	Every 5 years	

## 8.3 Changing the Oil



### NOTE

#### Use of unsuitable oil or too little oil.

Danger of premature failure and damage to the vacuum pump.

- ▶ Only use oils approved and recommended by Schmalz.
- ▶ Maintain the oil level between the MIN and MAX marks.

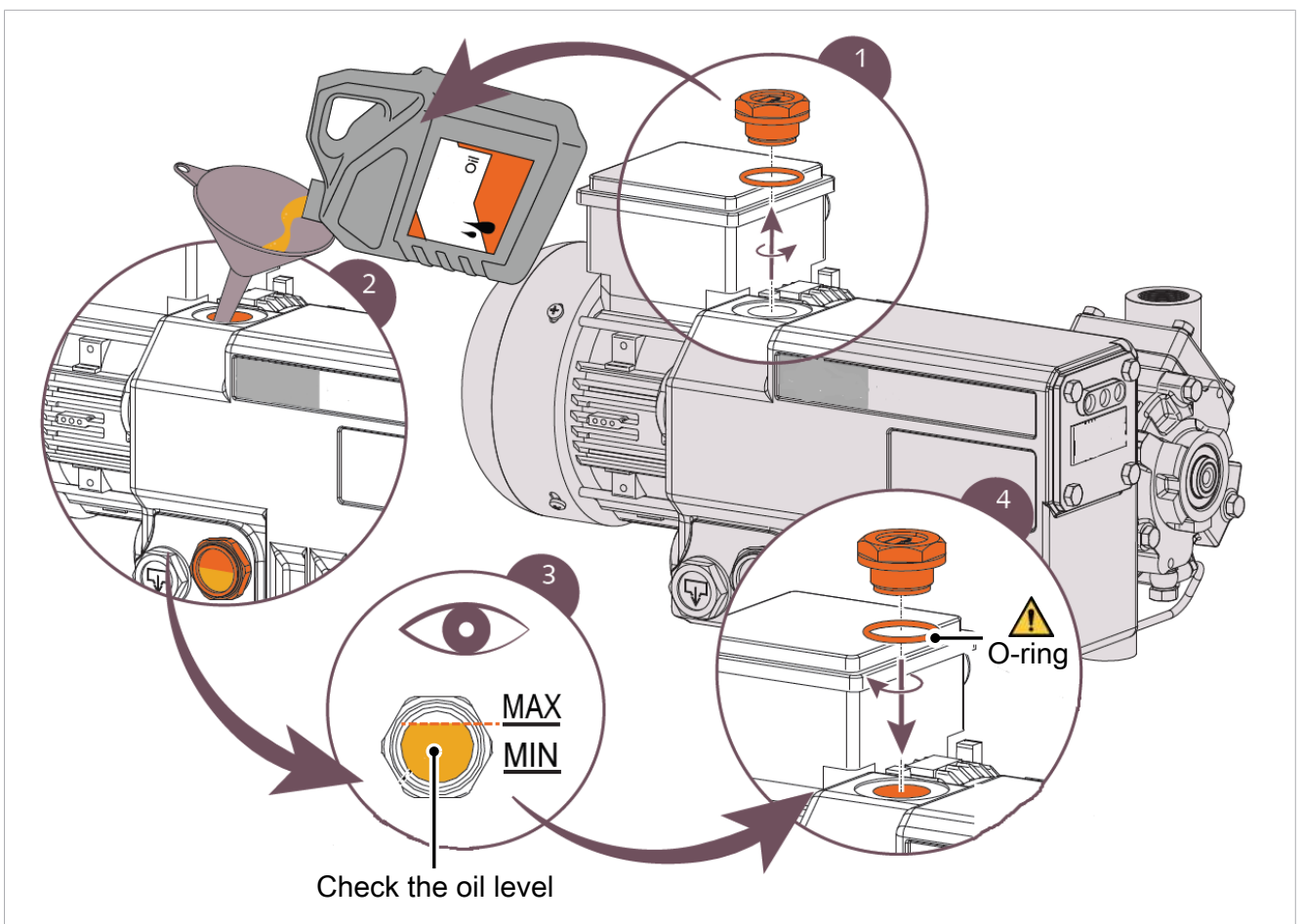
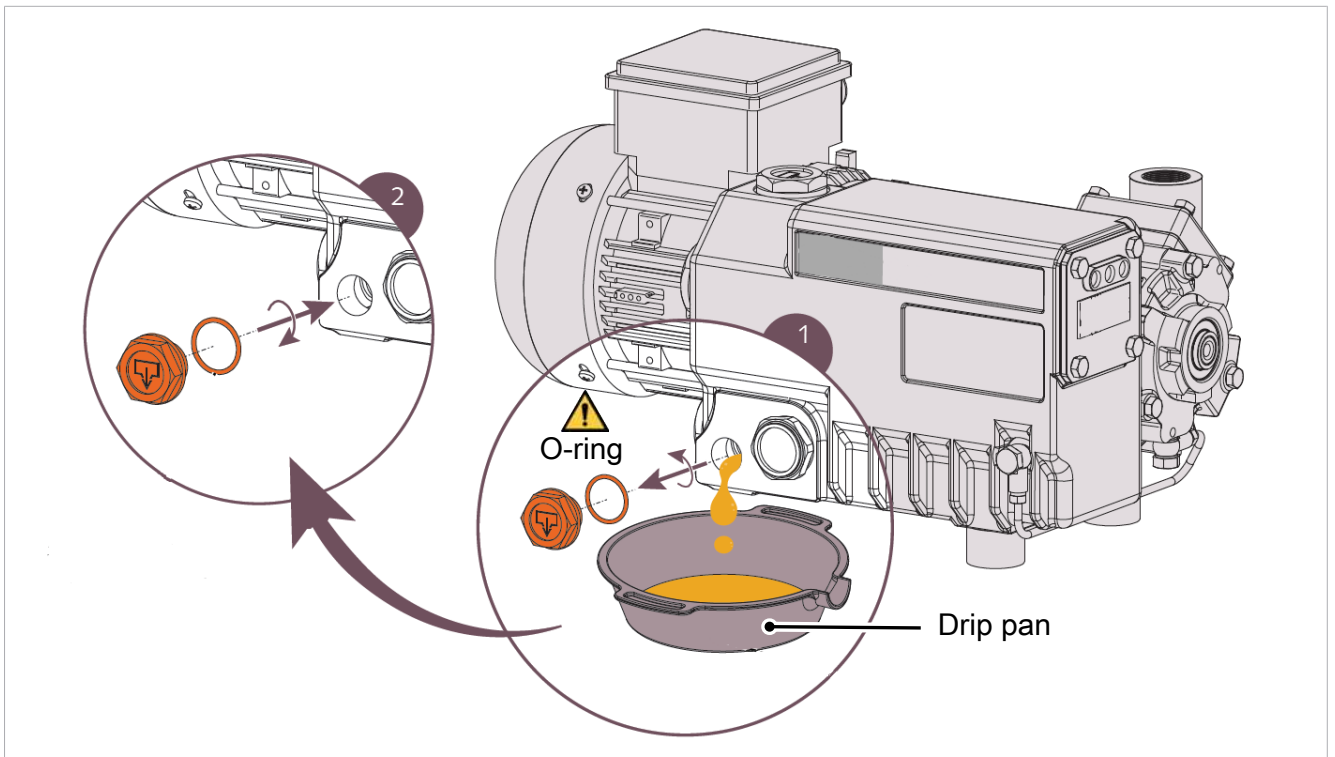

### 8.4 Changing the Air-Oil Separator

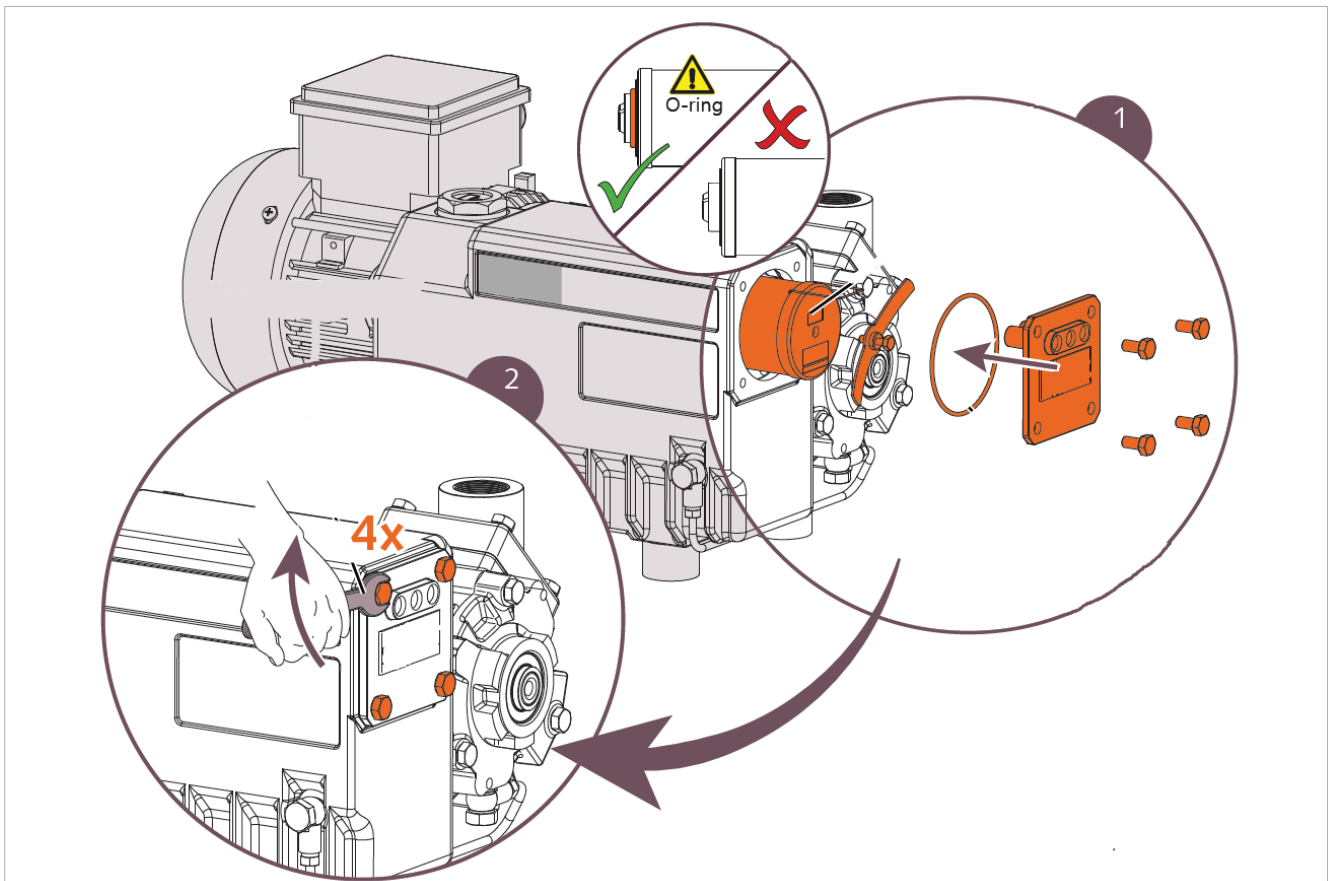
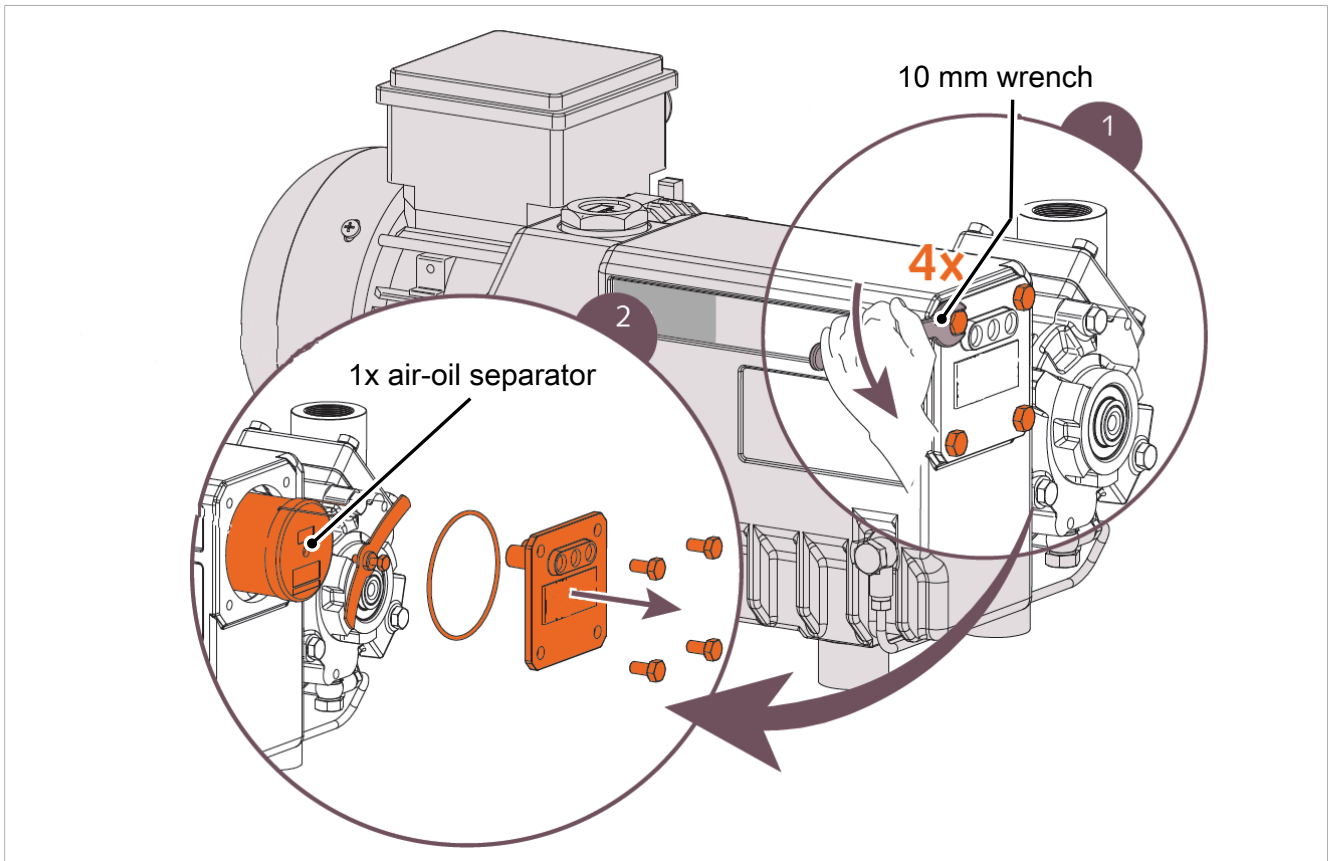



## 8.5 Cleaning the Pump

- ✓ Pump or drive disconnected from the power supply and free of voltage
- ✓ Pump free of hazardous substances
- ✓ Hoses removed from the pump head
- ▶ If necessary, clean the exterior of the pump using a dry cleaning cloth. Do not use solvents during cleaning work because they may affect plastic parts.

## 9 Warranty

### **IMPORTANT!**

A warranty claim can only be accepted by Schmalz if the pump has been installed and used in accordance with its corresponding operating instructions. In the case of inappropriate handling or use of force, any warranty and liability claims shall be void.

Damage and defects resulting from inadequate maintenance and cleaning, improper use, repair or attempted repair by unauthorized persons, as well as damage and defects resulting from alterations or modifications to the pump and from replaced parts or materials that do not conform to the original specification are excluded from the warranty.

## 10 Repair



### NOTE

#### Improper assembly

There is a risk of premature failure of the machine.

Loss of efficiency.

- ▶ We recommend that any disassembly of the machine that goes beyond the procedures described in these operating instructions be carried out by Schmalz.



### WARNING

#### Machine contaminated with hazardous material.

Danger of poisoning. There is a risk of infection.

- ▶ Wear appropriate personal safety equipment.

If the vacuum pump was used to convey gas contaminated with foreign substances that are hazardous to health, proceed as follows:

- ▶ Decontaminate the vacuum pump to the greatest degree possible and indicate the contamination status on a "Decontamination Declaration" (> [See ch. 17 Declaration of Decontamination, Page 36](#)).

Schmalz only accepts vacuum pumps accompanied by a completely filled out and legally-binding, signed "Declaration of Contamination."

# 11 Troubleshooting

## 11.1 Safety Instructions for Troubleshooting



### **⚠ DANGER**

#### **Electrocution by live components or wires**

Serious injury or death!

- ▶ Electrical installation work may only be carried out by qualified personnel.
- ▶ Make sure that the electrical components are not live before installation, maintenance and troubleshooting.
- ▶ Switch off the mains switch and secure against unauthorized restart.



### **⚠ CAUTION**

#### **Touching hot surfaces**

Touching hot surfaces may cause injury from burns.

- ▶ Wear work gloves.
- ▶ Do not touch components during operation.
- ▶ Allow the components to cool down before commencing work on the product.

## 11.2 Troubleshooting

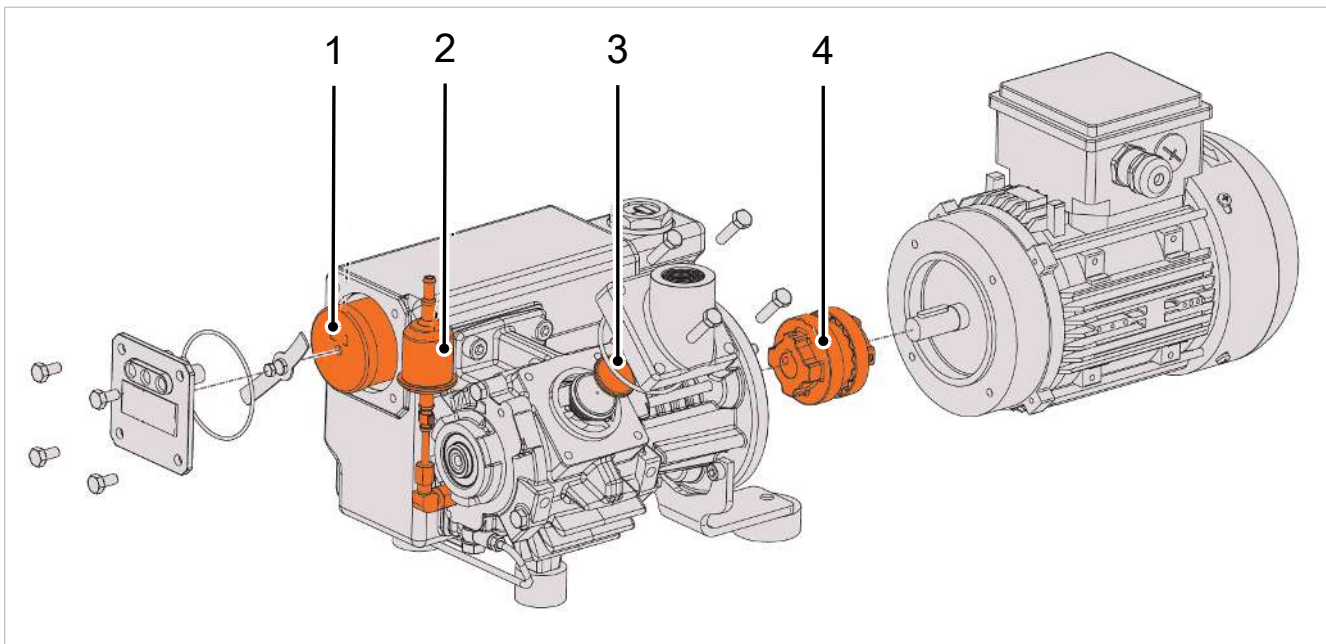

1	Air-oil separator
2	Gas ballast valve

3	Inlet screen
4	Coupling

Fault	Cause	Troubleshooting
The vacuum pump does not start	The required voltage is not applied to the motor.	▶ Check the power supply.
	The motor is faulty.	▶ Replace the motor.
	The coupler is faulty.	1. Replace the coupler. 2. Fill with oil.
The normal pressure cannot be generated at the suction connection.	The oil level is too low.	▶ Fill with oil.
	The inlet screen is partially clogged.	▶ Clean the inlet screen.
	The air filter insert (optional) is partially clogged.	▶ Replace the air filter insert.
	Internal components are worn or damaged.	▶ Have the vacuum pump repaired by Schmalz.
Too much noise is generated during operation of the vacuum pump.	The coupler is worn.	▶ Replace the coupler.
	The slides are stuck.	▶ Have the vacuum pump repaired by Schmalz.
	The bearings are faulty.	
Too much heat is generated during operation of the vacuum pump.	Cooling is insufficient.	1. Clean dust and contamination from the vacuum pump. 2. Check the cooling fan.
	The ambient temperature is too high.	▶ Observe the permissible ambient temperature.
	The oil level is too low.	▶ Fill with oil.
	The air-oil separator is partially clogged.	▶ Replace the air-oil separator.
Vapors and/or drops of oil escape from the gas outlet.	The air-oil separator is partially clogged.	▶ Replace the air-oil separator.
	The air-oil separator and O-rings are not properly installed.	▶ Correctly position the air-oil separator and O-ring.
	The float valve does not function properly.	▶ Check if the float valve and/or oil line are clogged. Remove the clog.
	Version with oil return valve: The machine is in a state of continuous operation for more than 2 hours.	▶ Briefly switch off the vacuum pump at regular intervals (version with oil return valve).
The oil is black.	The period of time between oil changes is too long.	▶ Rinse the vacuum pump. Contact a Schmalz representative about this.
	The air filter (optional) is faulty.	▶ Replace the air filter.
	Too much heat is generated during operation of the vacuum pump.	▶ Refer to "Too much heat is generated during operation of the vacuum pump."

### Malfunction cannot be corrected!

If you cannot identify any of the listed causes, send the vacuum pump to the Schmalz customer service (see the first page for the address).

1. Disconnect the power supply and remove the vacuum pump.
2. Clean the vacuum pump (> [See ch. 8.5 Cleaning the Pump, Page 25](#)).

3. Send the vacuum pump to Schmalz together with the completed declaration of decontamination ([\(≥ See ch. 17 Declaration of Decontamination, Page 36\)](#)) and the specification of the conveyed medium.

## 12 Optional Accessories

### 12.1 Gas ballast valve

The gas ballast valve is used to add a finite amount of ambient air to the process gas in order to counteract steam condensation in the machine.

The gas ballast valve reduces the value of the maximum vacuum of the vacuum pump.

### 12.2 Inlet Filter

The inlet filter serves to protect the machine from dust and other solids in the process gas. The inlet filter is available with a paper or polyester filter.

## 13 Spare and Wearing Parts



### NOTE

#### Use of non-original (non-Schmalz) spare parts.

Danger of premature failure of the machine and loss of efficiency.

- ▶ The exclusive use of original spare parts is a prerequisite for the proper functioning of the system and for the validity of the warranty.

The following list contains the most important spare and wearing parts.

Type	Description	Part no.	Legend
VST EVE-OG-10-16C, pump wearing parts set	All required parts for maintenance are included	10.03.02.00075	Wearing part
FILT-EINS 3 65x70 PAP STF-3/4-IG	Filter cartridge for additional filter	10.07.01.00017	Spare part
OEL-EVE-OG-1	Replacement oil for vacuum pumps 1.00 L	27.02.01.00055	Wearing part

If other spare parts are required, proceed as follows:

- ▶ Request the detailed spare parts list from your Schmalz representative.



## 14 Taking the Product Out of Operation and Disposal

Only qualified specialist staff may prepare the product for disposal.

### Taking the product out of operation

1. Switch off and lock the machine to prevent it from being switched on accidentally.
2. Vent all connected lines to the atmospheric pressure.
3. Disconnect all connections.

### Disassembly and disposal

1. Drain the oil.
2. Remove the air-oil separators.
3. Remove the oil filter.
4. Separate hazardous waste from the machine.
5. Dispose of hazardous waste in accordance with applicable legal regulations.
6. Dispose of the machine as scrap metal.

For proper disposal, contact a company specializing in the disposal of technical goods and instruct the company to observe the applicable disposal and environmental regulations.

## 15 EU Conformity

### EU Declaration of Conformity

The manufacturer Schmalz confirms that the vacuum pump EVE-OG described in these operating instructions fulfills the following applicable EU directives:

2006/42/EC	Machinery Directive
2014/30/EU	Electromagnetic Compatibility
2011/65/EU	RoHS Directive

The following harmonized standards were applied:

EN ISO 12100	Safety of machinery — General principles for design — Risk assessment and risk reduction
EN ISO 13849-1	Safety of machinery - Safety-related parts of control systems - Part 1 General principles for design
EN ISO 13857	Safety of Machinery – Safety distances to prevent hazard zones being reached by upper and lower limbs
EN ISO 2151	Acoustics - Noise test code for compressors and vacuum pumps - Engineering method (grade 2)
EN 1012-1	Compressors and Vacuum Pumps - Safety requirements - Part 1: compressors
EN 1012-2: 1996 +A1:2009	Compressors and Vacuum Pumps - Safety requirements - Part 2: Vacuum pumps
EN 60204-1+A1+AC	Safety of machinery - Electrical equipment of machines - Part 1: General requirements
EN 61000-6-2+AC	Electromagnetic compatibility (EMC) - Part 6-2: Generic standards - Immunity for industrial environments
EN 61000-6-4+A1	Electromagnetic compatibility - Part 6-4: Generic standards - Emission standard for industrial environments
EN IEC 63000	Technical documentation for the assessment of electrical and electronic products with respect to the restriction of hazardous substances



The EU Declaration of Conformity valid at the time of product delivery is delivered with product or made available online. The standards and directives cited here reflect the status at the time of publication of the operating and assembly instructions.

## 16 UKCA Conformity

### Declaration of Conformity (UKCA)

The manufacturer Schmalz confirms that the product described in these operating instructions fulfills the following applicable UK regulations:

2008	Supply of Machinery (Safety) Regulations
2016	Electromagnetic Compatibility Regulations
2012	The Restriction of the Use of Certain Hazardous Substances in Electrical and Electronic Equipment Regulations

The following designated standards were applied:

EN ISO 12100	Safety of machinery — General principles for design — Risk assessment and risk reduction
EN ISO 13849-1	Safety of machinery - Safety-related parts of control systems - Part 1 General principles for design
EN ISO 13857	Safety of Machinery – Safety distances to prevent hazard zones being reached by upper and lower limbs
EN ISO 2151	Acoustics - Noise test code for compressors and vacuum pumps - Engineering method (grade 2)
EN 1012-1	Compressors and Vacuum Pumps - Safety requirements - Part 1: compressors
EN 1012-2: 1996 +A1:2009	Compressors and Vacuum Pumps - Safety requirements - Part 2: Vacuum pumps
EN 60204-1+A1+AC	Safety of machinery - Electrical equipment of machines - Part 1: General requirements
EN 61000-6-2+AC	Electromagnetic compatibility (EMC) - Part 6-2: Generic standards - Immunity for industrial environments
EN 61000-6-4+A1	Electromagnetic compatibility - Part 6-4: Generic standards - Emission standard for industrial environments
EN IEC 63000	Technical documentation for the assessment of electrical and electronic products with respect to the restriction of hazardous substances



The Declaration of Conformity (UKCA) valid at the time of product delivery is delivered with the product or made available online. The standards and directives cited here reflect the status at the time of publication of the operating and assembly instructions.

## 17 Declaration of Decontamination

- ✓ A customer certificate regarding the conveyed medium and pump cleaning (declaration of decontamination) is a prerequisite for Schmalz to repair the pump.
- ▶ **Copy** this page. Enter the pump model, serial number and the conveyed medium in the form below and send the signed form to the Schmalz customer service together with the flushed and cleaned pump.

J. Schmalz GmbH  
 Customer service  
 Johannes-Schmalz-Str. 1  
 72293 Glatten, Germany

### Customer Declaration of Decontamination for the Repair Order

We confirm that the following media were conveyed with the pump listed below and that the pump has been flushed and cleaned.

<b>Pump model</b>	
<b>Serial number</b>	
<b>Conveyed media</b>	Medium 1 ...
	Where applicable, medium 2 ...
	Where applicable, medium 3 ...
	Where applicable, medium 4 ...
	Where applicable, medium 5 ...

There are no aggressive, biological, radioactive, poisonous or other hazardous media in the pump.

Company

Date/signature



---

## At Your Service Worldwide



---

### Vacuum Automation

[WWW.SCHMALZ.COM/AUTOMATION](http://WWW.SCHMALZ.COM/AUTOMATION)

### Handling Systems

[WWW.SCHMALZ.COM/AUTOMATION](http://WWW.SCHMALZ.COM/AUTOMATION)

---

**J. Schmalz GmbH**  
Johannes-Schmalz-Str. 1  
72293 Glatten, Germany  
T: +49 (0) 7443 2403-0  
schmalz@schmalz.de  
WWW.SCHMALZ.COM