

Clamping Equipment for Schmalz Consoles (single-circuit)

Height 50 mm, 100 mm and 125 mm

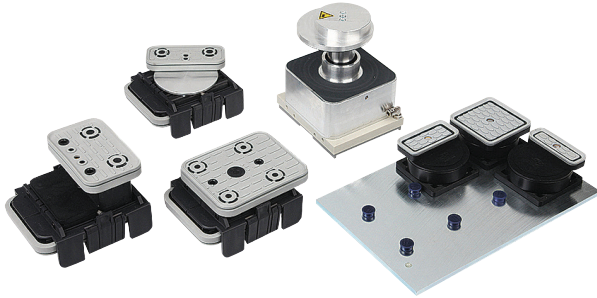

Clamping Equipment for Schmalz Consoles (single-circuit)

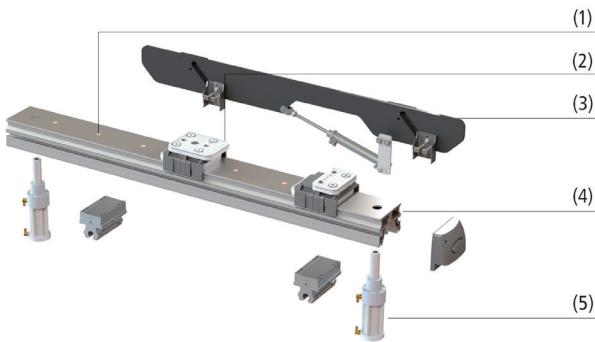

System Design Clamping Equipment for Schmalz Consoles (single-circuit)



Vacuum Block VCBL-K1 being used for clamping wooden workpieces

Suitability for Industry Specific Applications

Applications

- Hose-free vacuum clamping system for CNC machining centers with console table (1-circuit system)
- Enables damage-free clamping with the highest precision and holding force
- Vacuum blocks are pre-fixed to the consoles via guide strips and secured against movement during setup
- Vacuum is used to clamp the vacuum blocks to the console and the workpiece to the vacuum blocks

Design

- Schmalz Console (4) with hose free 1-circuit vacuum system (1)
- Mechanical prefixation of the vacuum block e.g. VCBL-K1 (2) on the console via guiding rails
- Panel lifting rail (3) for gentle loading and unloading of the CNC machining center
- Stop cylinder (5) of Schmalz for positioning of the workpiece

Our Highlights...

- Enormous holding forces
- Dimensional accuracy
- Wide range of different vacuum blocks
- Replacement suction plates

Your Benefits...

- Highest absorption of shear forces
- Enables highest accuracy in the production process
- Maximum flexibility and set-up time reduction
- Fast, easy and cost effective replacement of suction plates